

ACP-MxI Series AC Induction Gear Motor

User's Guide



ANAHEIM AUTOMATION

910 East Orangefair Lane, Anaheim, CA 92801
e-mail: info@anaheimautomation.com

(714) 992-6990 fax: (714) 992-0471
website: www.anaheimautomation.com

ACP-Mxl AC Induction Gear Motor Features

- Brushless Design for Long Life and Quiet Operation
- 110/220 VAC Input
- Single or Three Phase Input available
- Rated for Continuous Operation
- High Power Factor up to 0.8
- Self Starting
- UL Certified
- Output from 6 to 150 Watts
- High Starting Torque for High Inertial Loads
- Reduction Ratio's from 3.6 to 1800:1
- Precise Helical Gearsets
- Gear Boxes are Hermetically sealed to ensure Lubrication
- Gears Conform with JIS Class - 4 AGMA Class - 8
- Direct Replacement for some Panasonic AC Induction motors

General Description

The ACP-Mxl Series are fractional horsepower induction motors. ACP-Mxl series provide users that need a simple solution. The ACP-Mxl offers different sizes to accommodate your needs. These AC Induction motors can be customized to have a clutch and/or brake. ACP-Mxl series operate at 120 or 220VAC, so there is no need for a transformer, just hook up and go! ACP-Mxl series AC Induction motors can also be mated with other accessories, another reason to choose Anaheim Automation for your AC Induction motor projects.

ACP-Mxl series can be tailored with three phase AC Input. Three phase AC Induction motors are used when efficiency needs to be at its highest. A benefit of having a three phase AC Induction motor is without the need of a starting capacitor. Our three phase AC Induction motors offer great starting torque compared to other three phase AC induction motors.

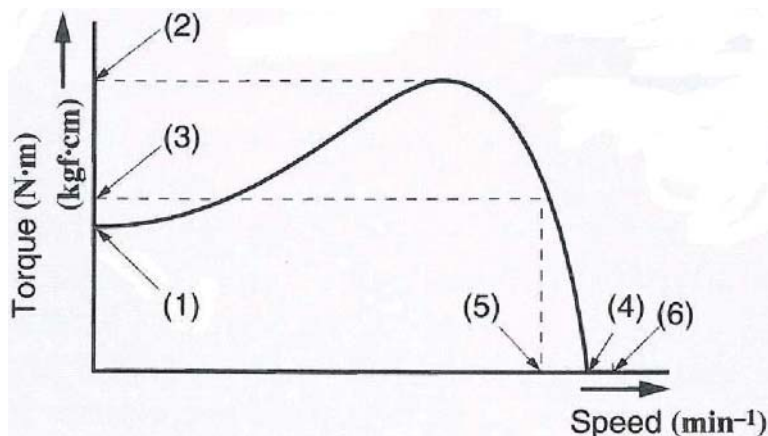

- Speed-torque characteristics
- (1) Starting torque
- (2) Stalling torque
- (3) Rated torque
- (4) No load speed
- (5) Rated speed
- (6) Synchronous speed

Wiring Diagram

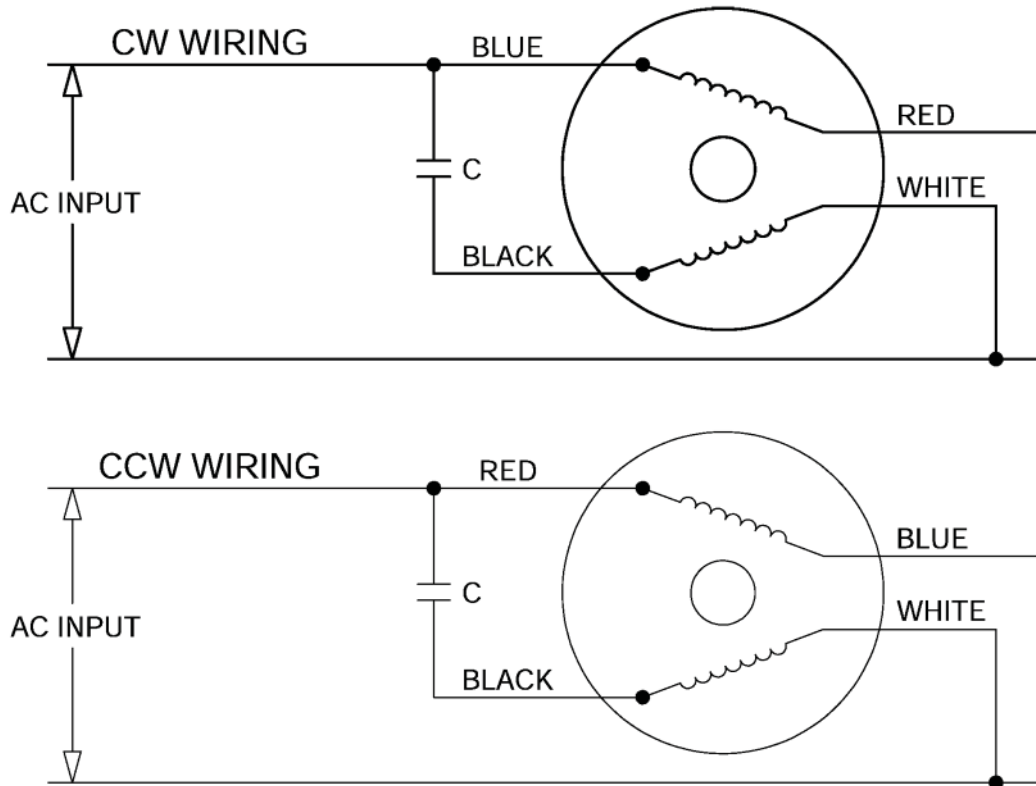

Part Number	uF	Voltage
ACP-M-2IK6A-AU	2.5	250
ACP-M-3IK15A-AU	4	250
ACP-M-4IK25A-AU	6	250
ACP-M-5IK40A-AU	8	250
ACP-M-5IK60A-AFU	16	250
ACP-M-5IK90A-AFU	20	250
ACP-M-5IK120A-AF	25	250
ACP-M-5IK150A-AF	36	250

Part Number	uF	Voltage
ACP-M-2IK6A-CU	0.8	450
ACP-M-3IK15A-CU	1	450
ACP-M-4IK25A-CU	1.5	450
ACP-M-5IK40A-CU	2	450
ACP-M-5IK60A-CFU	4	450
ACP-M-5IK90A-CFU	5	450
ACP-M-5IK120A-CF	7	450
ACP-M-5IK150A-CF	8	450

Power Supply Requirements

It is recommended that the ACP-Mxl Series be powered by 120 VAC for the ACP-M-xlxxx-Ax or 220 VAC for the ACP-M-xlxxx-Cx series.

Absolute Maximum Ratings

Input Voltage for ACP-M-xlxxx-Ax: 130 VAC
 Input Voltage for ACP-M-xlxxx-Cx: 240 VAC
 Max Case Temperature: 80°C
 Storage Temperature: 0° to +50°C

Temperature consideration: Use additional airflow and/or heatsinking to keep motor temperature under 80°C.

Part Number	Poles	No Load Speed (RPM)	Rated Load Speed (RPM)	Starting Current (A)	Rated Current (A)	Starting Torque (oz-in)	Rated Torque (oz-in)	Maximum Torque (oz-in)
ACP-M-2IK6N-AU	4	1800	1550	0.41	0.25	5.7	7.2	14.4
ACP-M-3IK15N-AU	4	1800	1600	0.59	0.34	12.5	12.5	25
ACP-M-4IK25N-AU	4	1800	1500	0.91	0.49	19.4	25	50
ACP-M-5IK40N-AU	4	1800	1575	1.5	0.74	33.3	37.5	75
ACP-M-5IK60U-AFU	4	1800	1550	2.2	1.06	62.5	52.7	105.4
ACP-M-5IK90U-AFU	4	1800	1625	3.1	1.7	66	73.6	147.2
ACP-M-5IK120U-AFU	4	1800	1610	2.85	1.65	107	101	202
ACP-M-5IK150U-AFU	4	1800	1512	3.3	2.61	126.4	137.5	275

Part Number	Poles	No Load Speed (RPM)	Rated Load Speed (RPM)	Starting Current (A)	Rated Current (A)	Starting Torque (oz-in)	Rated Torque (oz-in)	Maximum Torque (oz-in)
ACP-M-2IK6N-CU	4	1800	1550	0.21	0.13	5.7	7.2	14.4
ACP-M-3IK15N-CU	4	1800	1600	0.3	0.17	12.5	12.5	25
ACP-M-4IK25N-CU	4	1800	1625	0.55	0.24	19.4	25	50
ACP-M-5IK40N-CU	4	1800	1590	0.75	0.31	33.3	37.5	75
ACP-M-5IK60U-CFU	4	1800	1550	1.1	0.54	62.5	52.7	105.4
ACP-M-5IK90U-CFU	4	1800	1625	1.6	0.85	66	73.6	147.2
ACP-M-5IK120U-CFU	4	1800	1615	1.52	0.92	119	104	208
ACP-M-5IK150U-CFU	4	1800	1560	1.7	1.07	130	130	260

Gear Head Part Number	Ratio	Maximum Torque (oz-in)
ACP-G-2N3.6-K	3.6	13.8
ACP-G-2N6-K	6	22
ACP-G-2N9-K	9	34
ACP-G-2N10-K	10	37
ACP-G-2N15-K	15	57
ACP-G-2N18-K	18	69
ACP-G-2N20-K	20	74
ACP-G-2N30-K	30	112
ACP-G-2N36-K	36	134
ACP-G-2N60-K	60	222
ACP-G-2N90-K	90	319
ACP-G-2N120-K	120	347
ACP-G-2N180-K	180	347
ACP-G-2N10X-K	10	347

Gear Head Part Number	Ratio	Maximum Torque (oz-in)
ACP-G-3N3.6-K	3.6	33
ACP-G-3N6-K	6	55
ACP-G-3N9-K	9	83
ACP-G-3N10-K	10	93
ACP-G-3N15-K	15	138
ACP-G-3N18-K	18	166
ACP-G-3N20-K	20	180
ACP-G-3N30-K	30	263
ACP-G-3N36-K	36	319
ACP-G-3N60-K	60	541
ACP-G-3N90-K	90	694
ACP-G-3N120-K	120	694
ACP-G-3N180-K	180	694
ACP-G-3N10X-K	10	694

Gear Head Part Number	Ratio	Maximum Torque (oz-in)
ACP-G-4N3.6-K	3.6	55
ACP-G-4N6-K	6	93
ACP-G-4N9-K	9	138
ACP-G-4N10-K	10	152
ACP-G-4N15-K	15	222
ACP-G-4N18-K	18	277
ACP-G-4N20-K	20	291
ACP-G-4N30-K	30	444
ACP-G-4N36-K	36	541
ACP-G-4N60-K	60	901
ACP-G-4N90-K	90	1110
ACP-G-4N120-K	120	1110
ACP-G-4N180-K	180	1110
ACP-G-4N10X-K	10	1110

Gear Head Part Number	Ratio	Maximum Torque (oz-in)
ACP-G-5U3.6K	3.6	194
ACP-G-5U6-K	6	319
ACP-G-5U9-K	9	486
ACP-G-5U10-K	10	527
ACP-G-5U15-K	15	805
ACP-G-5U18-K	18	958
ACP-G-5U20-K	20	1069
ACP-G-5U30-K	30	1541
ACP-G-5U36-K	36	1847
ACP-G-5U60-K	60	2777
ACP-G-5U90-K	90	2777
ACP-G-5U120-K	120	2777
ACP-G-5U180-K	180	2777
ACP-G-5U10X-K	10	2777

Note:

For higher gear ratio's, please add the ACP-x(U/N)10(X/L)-K to multiply any of the gear ratio's by 10. Up to a maximum ratio of 1800:1 is only allowed.

Example:

A ratio of 200:1 is needed with the following motor: ACP-M-3IK15N-xx. The required part numbers are: **ACP-G-3N20-K** and **ACP-G-3N10X-K**

Dimensions

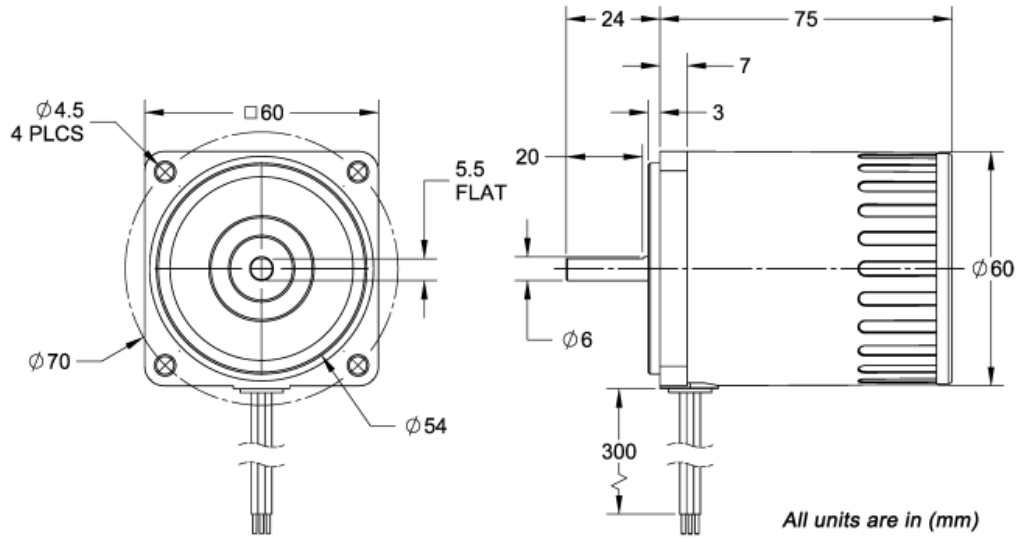

Figure 4: Dimensions for ACP-M-2IK6A-(A)(C)UV

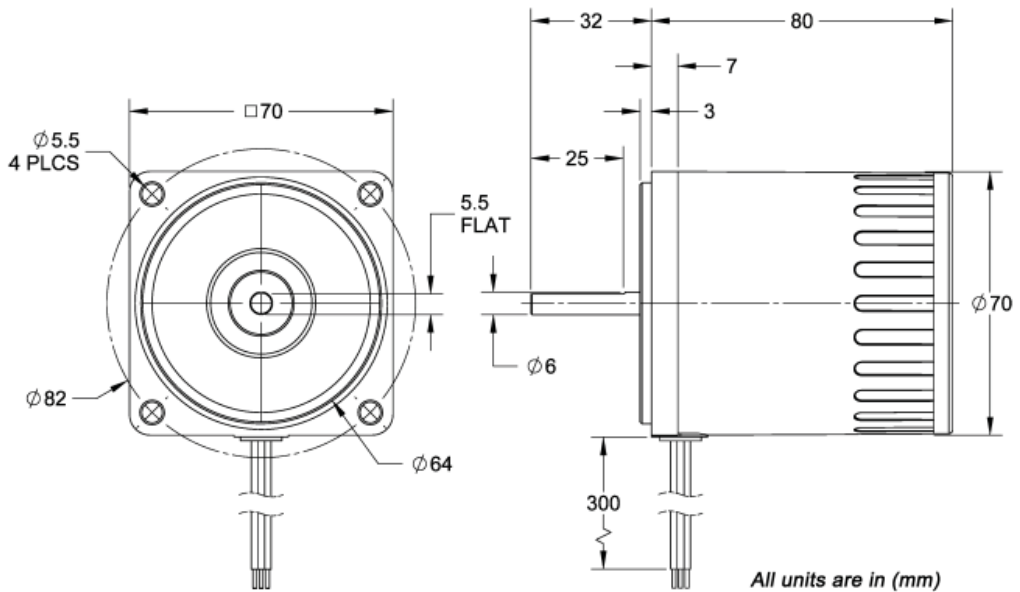
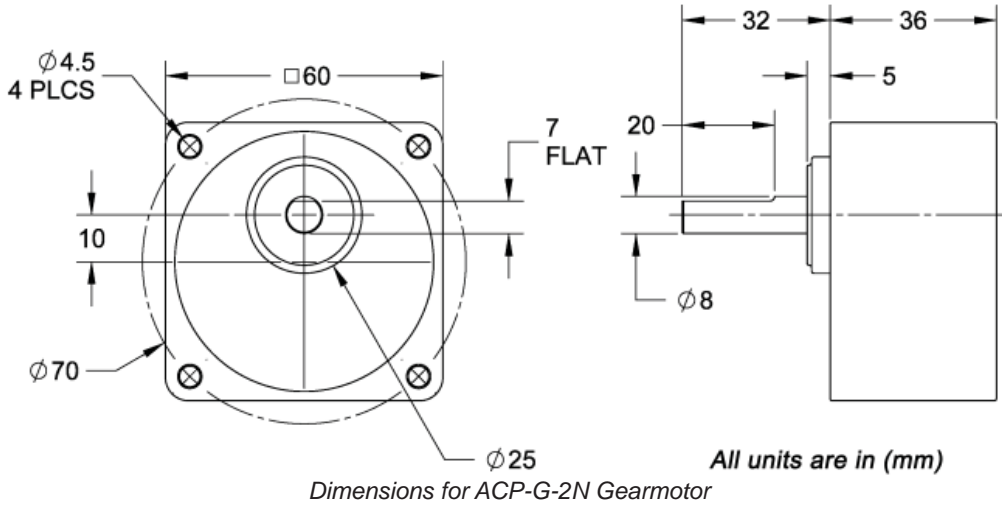
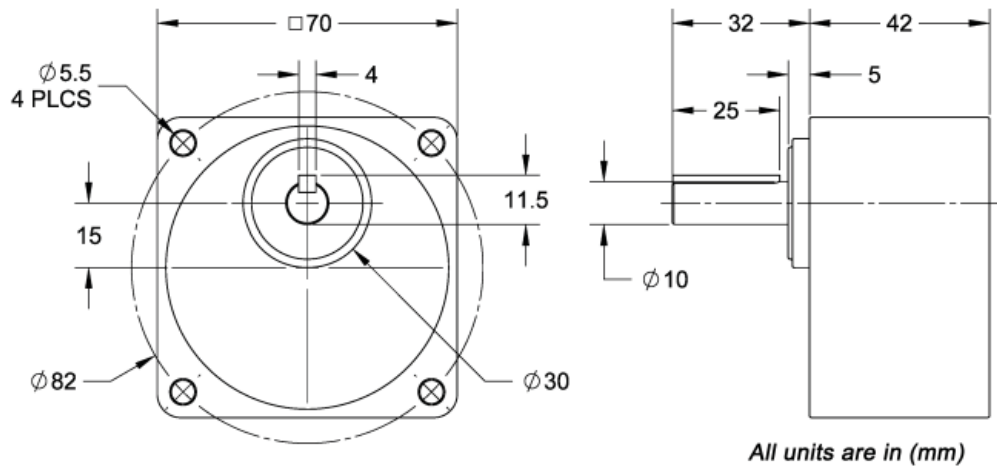

Figure 5: Dimensions for ACP-M-3IK15A-(A)(C)UV



Dimensions for ACP-G-3N Gearmotor

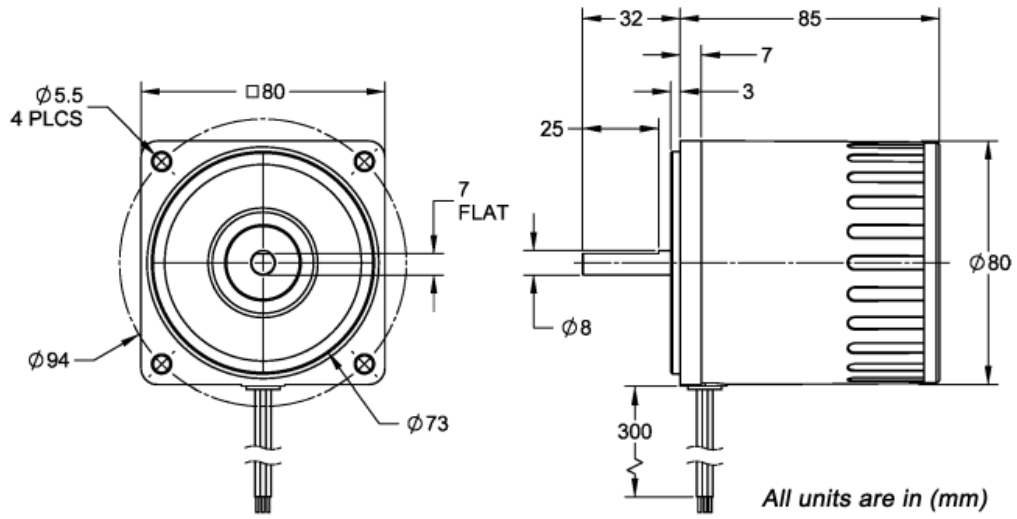
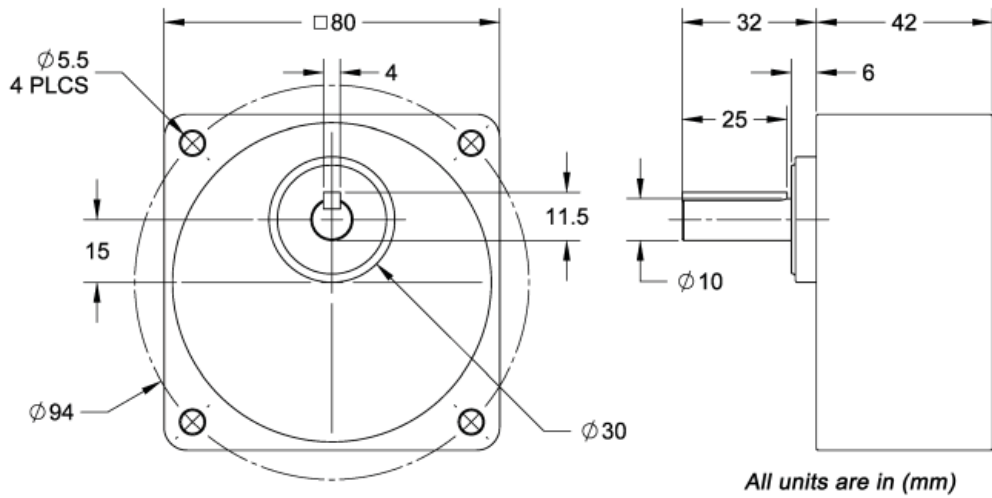

Figure 6: Dimensions for ACP-M-4IK25A-(A)(C)UV



Dimensions for ACP-G-4N Gearmotor

Dimensions

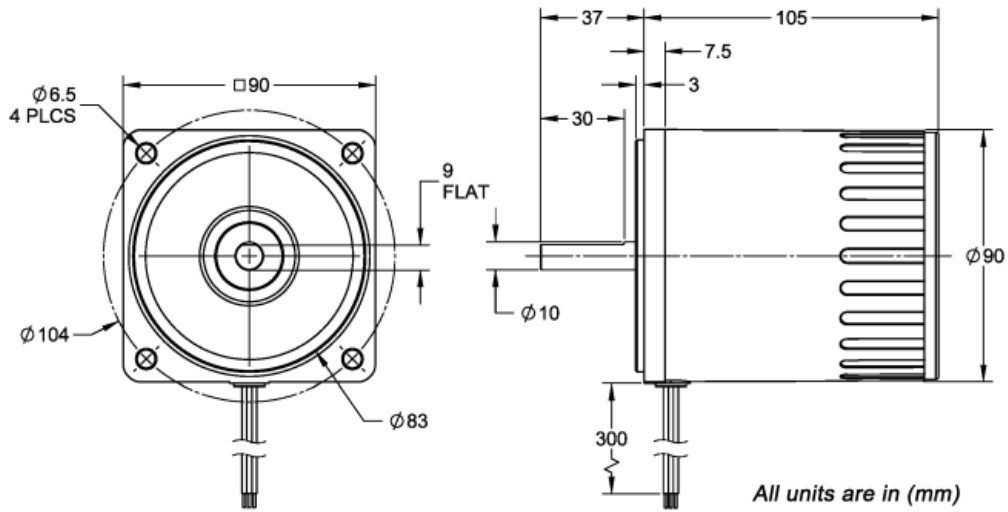

Figure 7: Dimensions for ACP-M-5IK40A-(A)(C)UV

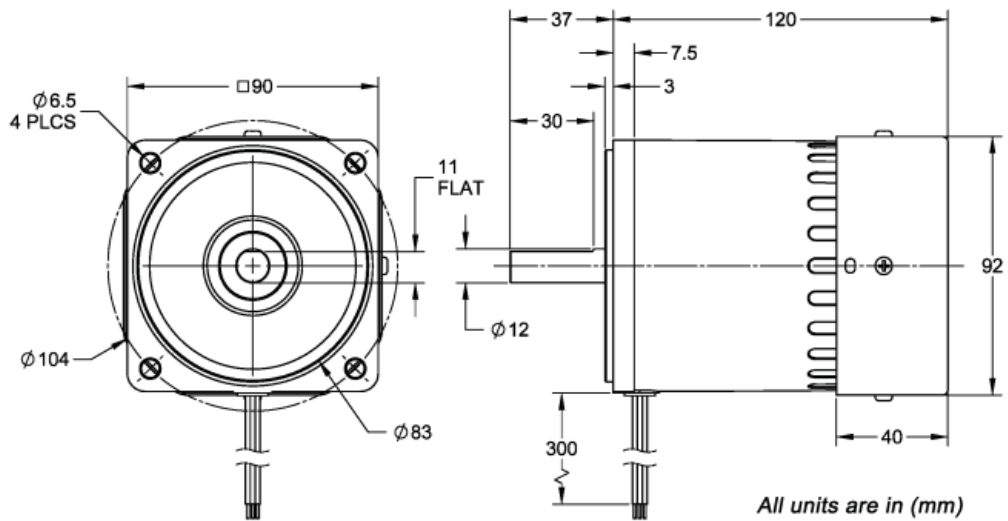
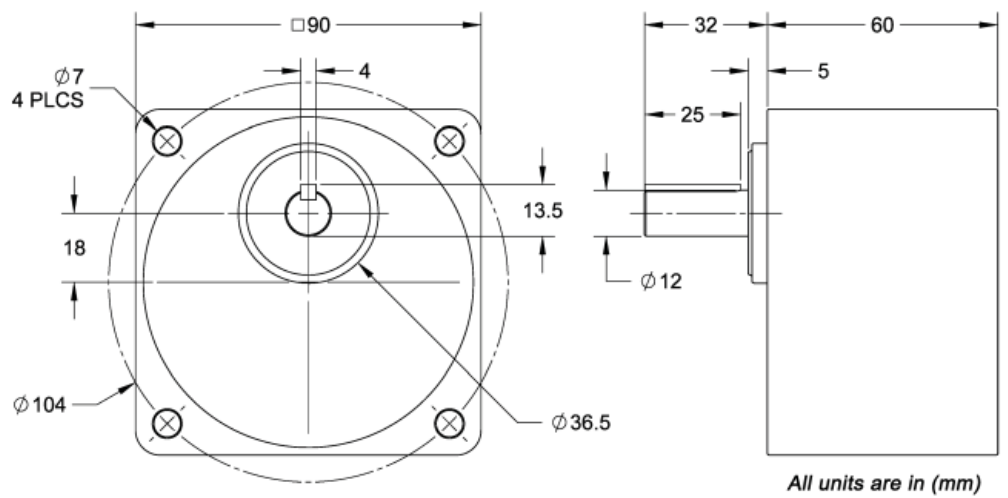

Figure 8: Dimensions for ACP-M-5IK60A-(A)(C)UV



Dimensions for ACP-G-5N Gearmotor

Dimensions

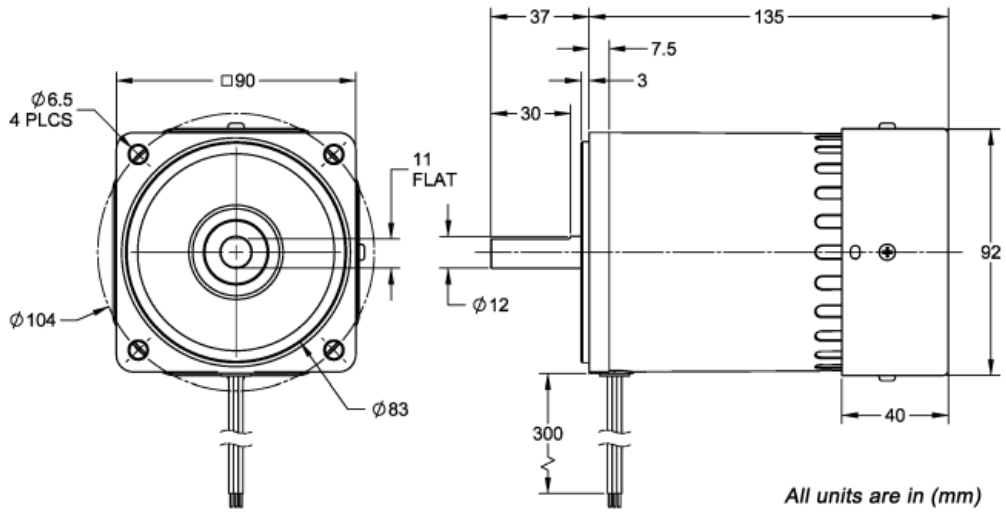
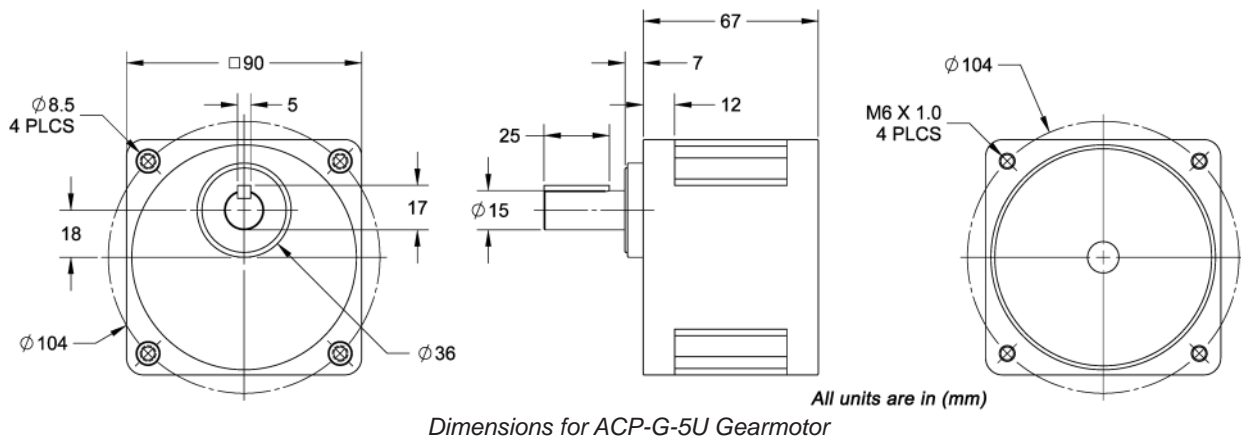

Figure 9: Dimensions for ACP-M-5IK90A-(A)(C)UV, ACP-M-5IK120A-(A)(C)UV, ACP-M-5IK150A-(A)(C)UV



Gearhead Installation Instructions

Assembly

1. Take off the seal cap and clean the grease on the end of the surface. (Figure 13)
2. Take off the O-Ring from the seal cap, and loop it flatly around the flange or motor bracket. (Figure 14)
3. Turn the motor upwards and take off the shaft-sheath as Figure 14.
4. Please refer to figure 15. Proper alignment is necessary when assembling gearhead with motor.
5. After assembling, please fasten the 4 exclusive bolts diagonally (Figure 16). Please fasten bolts to the required torque specifications. Table 2

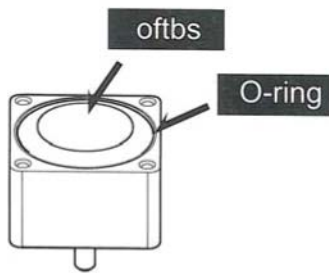

Figure 13.

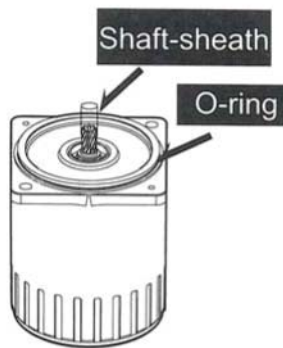

Figure 14.

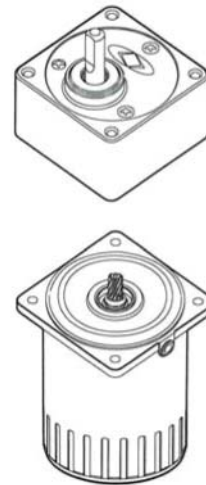

Figure 15.

Frame Size (mm)	Bolt Size	Torque (ft-lb)
60	M4	1.4
70	M5	1.8
80	M5	1.8
90	M6	2.2

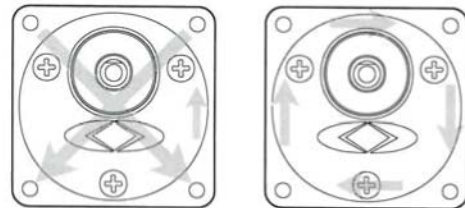

Figure 16.

Storage

1. Keep the output shaft downwards when storing the gearhead. (Figure 17)
2. Reserve the gearhead with O-Ring and seal-cap to prevent grease from escaping the Gearhead. (Figure 18)
3. Improper assembly of the motor and/or gearhead can cause noise and diminish the lifetime.

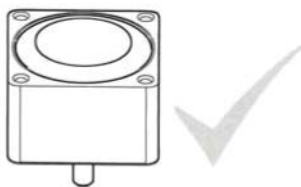

Figure 17.

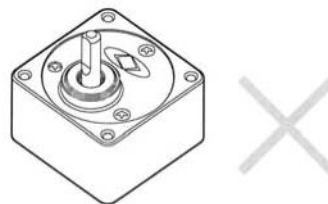

Figure 18.

AC Induction Motor FAQ

What happens if I remove the internal brake mechanism of an AC induction reversible motor? Can I then use it as a regular AC induction motor?

An AC reversible motor is an AC induction motor, but is made different. An AC reversible motor has its coils wound specifically for the application of a quick reversal movement. The AC reversible motor has its primary and secondary coils altered. Having a different ratio between the primary and secondary coils, its starting torque characteristics will be changed. This change makes it have the instant reversing characteristics. Moreover, the capacitor has been changed also to increase the starting torque. Therefore, removing just the internal brake mechanism won't help make the reversible motor run continuously.

Why do AC induction reversible motors have a 30 minute rating?

Due to the construction and the purpose of the AC reversible motor, it won't allow running more than 30 minutes. The reason being is that a reversible motor requires a higher input power than an AC induction motor. The higher input power is used for the increased starting torque and instant reversing characteristics. There are higher losses in a reversible motor than a regular AC induction motor. Running the motor for more than 30 minutes can cause the motor to burn up. Therefore, for maximum performance, it is recommended for 30 minutes of use at a time.

Can I run an AC induction reversible motor longer than 30 minutes?

You can increase the running time of the motor if heating considerations are taken care of. The motor casing should be below 80 degrees Centigrade.

Can I run an AC induction reversible motor 30 minutes in one direction then 30 minutes in the other?

The 30 minute rating is for the total time that the motor is on, regardless of direction.

Can I use a solid state relay (SSR) to switch the direction?

When using a SSR to switch direction, please allow at minimum of 100ms before switching to the other direction.

Can I use a capacitor other than the one it came with?

The capacitor that came with the motor was chosen for optimum stability and performance. When using another capacitor, use the recommended capacitance and voltage values when obtaining another capacitor. The use of non-polarized capacitors should be used. For example, Electrolytic capacitors should not be used.

What happens if I use a different capacitor value other what has been given?

When using a different capacitor value, the AC induction motor may or may not start up. Erratic

How does power supply fluctuation affect AC Induction motor?

The fluctuations of voltage will affect the torque output of the motor. The torque developed by an AC induction motor is proportional to the square of the applied voltage.

For example:

Rated Voltage: 100VAC

Stall Torque, T_m : .5 Nm

Starting Torque, T_s : .25Nm

The voltage is then reduced to 75VAC:

New T_m : $[.5*(75/100)^2]=.375$ Nm

New T_s : $[.25*(75/100)^2]=.1875$ Nm

If the motor is going to experience power fluctuations, please take it into account when choosing an AC induction motor.

COPYRIGHT

Copyright 2012 by Anaheim Automation. All rights reserved. No part of this publication may be reproduced, transmitted, transcribed, stored in a retrieval system, or translated into any language, in any form or by any means, electronic, mechanical, magnetic, optical, chemical, manual, or otherwise, without the prior written permission of Anaheim Automation, 910 E. Orangefair Lane, Anaheim, CA 92801.

DISCLAIMER

Though every effort has been made to supply complete and accurate information in this manual, the contents are subject to change without notice or obligation to inform the buyer. **In no event will Anaheim Automation be liable for direct, indirect, special, incidental, or consequential damages arising out of the use or inability to use the product or documentation.**

Anaheim Automation's general policy does not recommend the use of its' products in life support applications wherein a failure or malfunction of the product may directly threaten life or injury. Per Anaheim Automation's Terms and Conditions, the user of Anaheim Automation products in life support applications assumes all risks of such use and indemnifies Anaheim Automation against all damages.

LIMITED WARRANTY

All Anaheim Automation products are warranted against defects in workmanship, materials and construction, when used under Normal Operating Conditions and when used in accordance with specifications. This warranty shall be in effect for a period of twelve months from the date of purchase or eighteen months from the date of manufacture, whichever comes first. **Warranty provisions may be voided if products are subjected to physical modifications, damage, abuse, or misuse.**

Anaheim Automation will repair or replace at its' option, any product which has been found to be defective and is within the warranty period, provided that the item is shipped freight prepaid, with previous authorization (RMA#) to Anaheim Automation's plant in Anaheim, California.

TECHNICAL SUPPORT

If you should require technical support or if you have problems using any of the equipment covered by this manual, please read the manual completely to see if it will answer the questions you have. If you need assistance beyond what this manual can provide, contact your Local Distributor where you purchased the unit, or contact the factory direct.

ANAHEIM AUTOMATION