

MDC151-0501001 - Brushless DC Controller



FEATURES

- Maximum Current Limit Setting from 50.0-100.0 Amps (peak)
- Internal or External Potentiometer Speed Control
- 0V to 5V External Voltage Speed Control
- 2-Quadrant Operation
- Hall Sensor Feedback
- Constant Velocity Mode
- Short Circuit Protection
- Requires 20-50VDC
- Run/Stop, Freewheel and Direction Inputs
- TTL-CMOS Compatible Inputs
- Detachable, Screw Type Terminal Blocks
- RoHS Compliant



DIMENSIONS

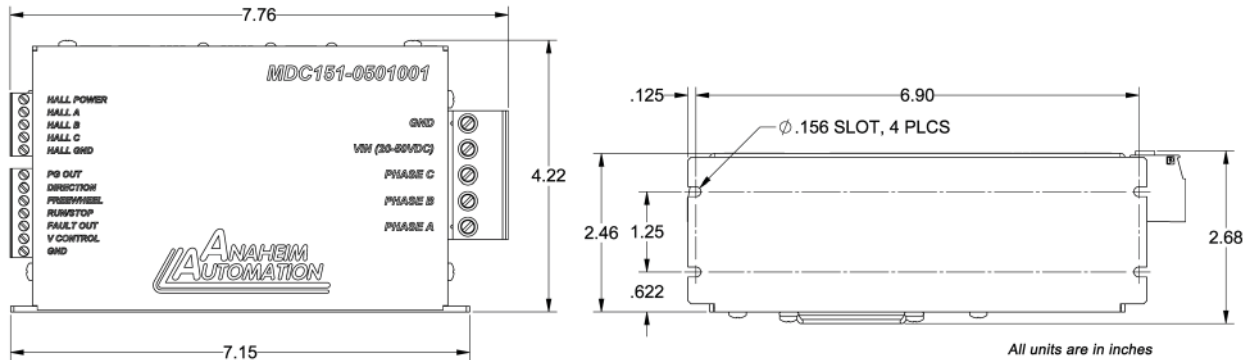

DESCRIPTION

The MDC151-0501001 driver is designed to drive DC brushless motors at currents of up to 50A (peak) and 50V. Using hall sensor feedback, a constant velocity mode can be selected. The driver is protected against over current (cycle-by-cycle or latched), hall sensor error and under voltage. When an error occurs, a fault light and fault output are turned on to notify the user. Included on the driver is an internal potentiometer to control the speed of the motor. An external voltage (0-5VDC) can be used to control the speed as well. The direction of the motor can be preset by the

L010890

direction control input. Other Inputs to the drive include a run/stop and a motor free-wheel input. When using the run/stop input, there are three ramp up/down profiles from standstill to select from. The run/stop input overrides all other inputs into the driver.

Ideal Applications:

Automated machinery or processes that involve food, cosmetic, or medical packaging, labeling, or tamper-evident requirements, electronic assembly robotics, factory automation, special filming, and project effects, medical diagnostics, inspection and security devices, conveyor and material handling systems, pump flow control, XY and rotary tables, equipment upgrades or whenever speed control is required.

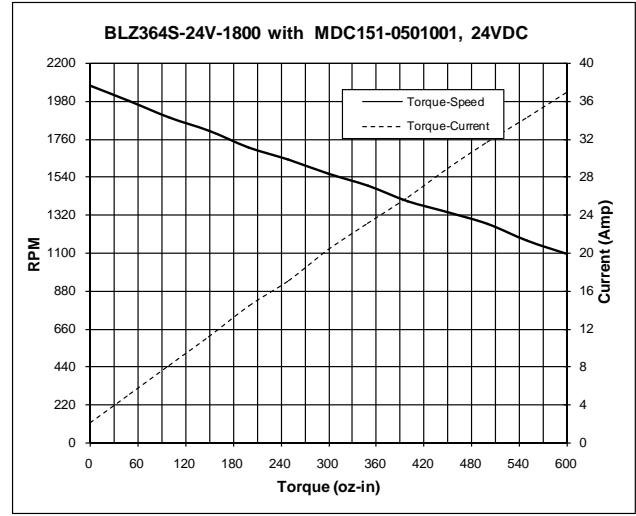
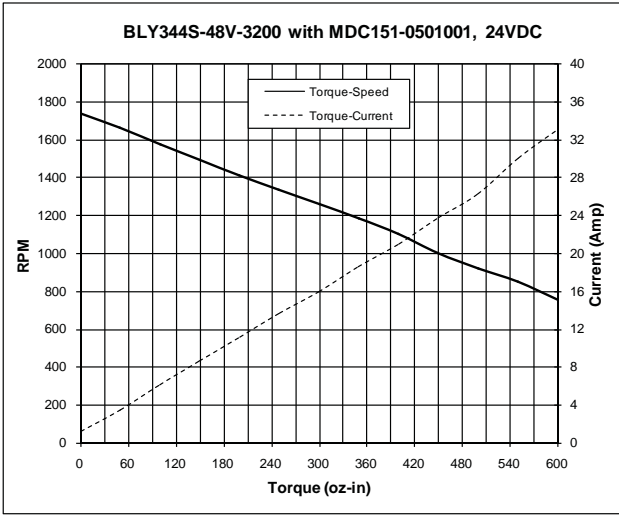

Control Inputs: (TB3, Pins 2-4) TTL-CMOS compatible
 Logic "0" = 0-0.8VDC
 Logic "1" = Open

Direction Control: (TB3, Pin 2) Logic "1" (open) - Clockwise
 Logic "0" - Counterclockwise

Freewheel: (TB3, Pin 3) Logic "1" (open) - Motor is Enabled
 Logic "0" - Motor is de-energized and will coast

Run/Stop: (TB3, Pin 4) Logic "1" (open) - Motor will not run and if running will decelerate accordingly to ramp dip switch setting
 Logic "0" - Motor will run and will accelerate according to ramp dip switch

V Control: (TB3, Pin 4) To control the speed of the motor with an external DC Voltage, INT/EXT SPD switch (SW1-POS1) must beswitch to the ON position. (0VDC (min) - 5VDC (max))

Control Outputs: (TB3, Pins 1 and 5) TTL-CMOS Compatible
 These outputs are able to sink 50mA.

Speed Output: (TB3, Pin 1) A 5V signal pulse out is available at a rate of 4 pulses for 1 revolution of an 8-pole motor, 3 pulses for 1 revolution of a 6-pole motor, and 2 pulses for 1 revolution of a 4-pole motor.
 8-pole motor RPM = 15 * PG OUT (in Hz)
 6-pole motor RPM = 20 * PG OUT (in Hz)
 4-pole motor RPM = 30 * PG OUT (in Hz)

Fault Output: (TB3, Pin 5) Logic "1" (5V out) - Status good, normal operation.
 Logic "0" - One of the three fault conditions listed in the 'Fault Protect' section has occur. When a fault is detected, the Fault Output (Pin 5) goes low.

Output Current Rating: Adjustable 50.0-100.0 amperes per phase maximum operating peak current (25.0-50.0 amperes per phase maximum operating continuous current)

Hall Sensor Power Outputs: 5V @ 30mA (Max)

Operating Temperature: Heat Sink: 0° - 70°C

Power Requirements 20VDC (min) - 50 VDC (max)

