

BSC151-024031 Series 24V, 3A Brushless Speed Controller

User's Guide



ANAHEIM AUTOMATION

910 East Orangefair Lane, Anaheim, CA 92801
e-mail: info@anaheimautomation.com

(714) 992-6990 fax: (714) 992-0471
website: www.anaheimautomation.com

BSC151-024031 Speed Controller Features

- Maximum Current Limit of 3.0 Amps (peak)
- Potentiometer Speed Control
- Integrated Power, Brake and Direction Switches
- Constant Velocity Mode
- Short Circuit Protection
- 2-Quadrant Operation
- Hall Sensor Feedback
- Requires 10-24VDC
- Speed Out

General Description

The BSC151-024031 is a speed controller that has integrated easy to use user controls and the MDC151-024031 driver inside and is designed to drive DC brushless motors at currents of up to 3A (peak) and 24V. Using hall sensor feedback, a constant velocity mode can be achieved. The driver is protected against over current (cycle-by-cycle or latched), hall sensor error and under voltage. When an error occurs, an internal fault light is turned on to notify the user. Included on the driver is an internal potentiometer to control closed loop compensation control. In addition, there are integrated control switches for power, the direction, Run/Stop, and a speed control potentiometer to adjust the motor speed mounted for easy user interface.

Fault Protection

Over current protection can be provided by means of an over current latch function by setting the 'FLT LATCH' dip switch. If a motor current level exceeding the current limit set by the internal or external current limit potentiometer is produced, an over current latch is activated, shutting off the motor phase outputs. This driver is equipped with an internal FAULT LED to alert the user of the following conditions.

1. Invalid Sensor Input Code
2. Over Current. The driver is equipped with cycle-by-cycle current limiting or over current latch.
3. Undervoltage Lockout activation at 9.1VDC for the input voltage and 4.5VDC for Hall Sensor voltage.

Specifications

Output Current Rating:

3 amperes per phase maximum operating peak current

Power Requirements:

10VDC (min) - 24VDC (max)

Operating Temperature:

Driver Heat Sink: 0° - 70°C

Hall Sensor Power Output:

6.25V @ 30mA maximum. Typical current draw from hall sensors is 20mA. All three hall sensor inputs are pulled up through 20K ohm resistors. Only the Motor Hall Power wire should be tied here.

Speed Output:

A 5V signal pulse out is available at a rate of 4 pulses for 1 revolution of an 8-pole motor, 3 pulses for 1 revolution of a 6-pole motor, and 2 pulses for 1 revolution of a 4-pole motor.

8-pole motor RPM = 15 * PG OUT (in Hz)

6-pole motor RPM = 20 * PG OUT (in Hz)

4-pole motor RPM = 30 * PG OUT (in Hz)

A pull-up resistor is needed for this open drain output.

This open drain pulse output has a max rating of 30VDC/50mA.

Closed Loop (Constant Velocity Mode)

The driver is set for Closed Loop operation. Closed Loop operation is used for applications where speed regulation is needed. Under closed loop operation, the speed is regulated despite changes to the load.

If using an Anaheim Automation DC Brushless motor, the tables shown on the next page are the Close Loop potentiometer and jumper settings for each motor. The regulated speed of the motor is then controlled by adjusting external speed input. The motor speed can be monitored by measuring the pulse rate of PG OUT (P1 - pin 7).

If using a non-Anaheim Automation DC Brushless Motor.

1. Start with setting the jumpers on pins 1 and 2.
2. Set CL Adjust Pot to 50%.
3. Adjust the external speed input to 5V.
4. Decrease the closed loop gain by turning the pot CCW until the motor speed decreases to the maximum speed. If the rated speed does not change or cannot be varied, switch the jumpers to pin 2 and 3.

Anaheim Automation Motor Closed Loop Settings

4-Pole Motors

Motor	JP1	CL POT	MAX SPD (RPM)
BLWR092S-24V-4600	1-2	75%	4600
BLWR110S-15V-8000	1-2	75%	8000
BLWR111S-12V-15000	1-2	75%	15000
BLWR111S-24V-10000	1-2	75%	10000
BLWR112S-24V-3700	1-2	25%	3700
BLWR112S-36V-10000*	1-2	75%	7500
BLWR132S-24V-4000	1-2	25%	4000
BLWR231S-36V-4000*	1-2	25%	3000
BLWR231S-24V-11000	1-2	75%	11000
BLWS231S-24V-2000	2-3	75%	2000
BLWS232S-24V-1350	2-3	75%	1350
BLWS233D-24V-4000	1-2	25%	4000
BLWS233S-24V-4000	1-2	25%	4000

8-Pole Motors

Motor	JP1	CL POT	MAX SPD (RPM)
BLY171S-17V-8000	1-2	75%	8000
BLY172S-17V-9500	1-2	75%	9500
BLY171S-24V-4000	1-2	75%	4000
BLY172D-24V-4000	1-2	75%	4000
BLY172S-24V-4000	1-2	75%	4000
BLY173D-24V-4000	1-2	75%	4000
BLY173S-24V-4000	1-2	75%	4000
BLY174D-24V-4000	1-2	75%	4000
BLY174S-24V-4000	1-2	75%	4000
BLY171S-12V-200	2-3	25%	200
BLY171S-15V-8000	1-2	75%	8000
BLY171S-17V-8000	1-2	75%	8000
BLY172D-12V-230	2-3	25%	230
BLY174D-24V-12000	1-2	75%	12000
BLY172S-12V-500	2-3	100%	500

***Note: 36V motors ran at 24VDC. Speed is set to run at 75% of rated value.**

Commutation Sequence

	Step					
	1	2	3	4	5	6
Phase A	+	Z	-	-	Z	+
Phase B	Z	+	+	Z	-	-
Phase C	-	-	Z	+	+	Z
Hall A	1	1	0	0	0	1
Hall B	0	1	1	1	0	0
Hall C	0	0	0	1	1	1

120° Hall Spacing Sequence Forward

	Step					
	1	2	3	4	5	6
Phase A	-	Z	+	+	Z	-
Phase B	Z	-	-	Z	+	+
Phase C	+	+	Z	-	-	Z
Hall A	1	1	0	0	0	1
Hall B	0	1	1	1	0	0
Hall C	0	0	0	1	1	1

120° Hall Spacing Sequence Reverse

	Step					
	1	2	3	4	5	6
Phase A	+	Z	-	-	Z	+
Phase B	Z	+	+	Z	-	-
Phase C	-	-	Z	+	+	Z
Hall A	1	1	1	0	0	0
Hall B	0	1	1	1	0	0
Hall C	0	0	1	1	1	0

60° Hall Spacing Sequence Forward

	Step					
	1	2	3	4	5	6
Phase A	-	Z	+	+	Z	-
Phase B	Z	-	-	Z	+	+
Phase C	+	+	Z	-	-	Z
Hall A	1	1	1	0	0	0
Hall B	0	1	1	1	0	0
Hall C	0	0	1	1	1	0

60° Hall Spacing Sequence Reverse

+ = Top Transistor ON, Bottom Transistor OFF, Current Flows into this wire

- = Top Transistor OFF, Bottom Transistor ON, Current Flows out of this wire

Z = Top Transistor OFF, Bottom Transistor OFF, No current into or out of this wire (High Impedance)

Motor Connection

Refer to the hookup diagram for typical driver applications. When connecting a motor for the first time, connect the hall sensor wires (5 of them) to the terminal strip. **DO NOT CONNECT THE PHASES YET.** Turn on power and rotate the motor by hand. If the RED FAULT LED comes on, the hall phases are incorrectly wired. If the RED FAULT LED does not come on then the hall wires are connected correctly. Power the unit down and proceed to connect the motor phases. If the motor does not run or runs erratically, power down and check the speed potentiometer and make sure the phases are connected correctly. There are six different ways to connect the phase wires, and normally only two will allow the motor to rotate, but only one is correct. If the direction of the motor is changed and the no-load current of the motor is approximately the same and the motor runs smoothly in both directions then the phase wires are correct.

The wiring of the motor phases should be separated from the hall and input connections to not allow a possible source of electrical interference.

Terminal Descriptions

Pin #	Description
1	VIN (10-24VDC)
2	GND
3	Run/Stop
4	Direction
5	Freewheel
6	VControl
7	PGout

P1: Power, Control Inputs and Outputs

Pin #	Description
1	Phase A
2	Phase B
3	Phase C
4	Hall Sensor Power
5	Hall Sensor A
6	Hall Sensor B
7	Hall Sensor C
8	Hall Sensor Ground

P2: Motor Hall Terminals and Motor Phase Terminals

Motor Freewheel

The motor freewheel feature allows the de-energizing of the motor phases. A high (open) input at this input causes the motor to run at the given speed, while a low at this input causes the motor to coast to a stop.

Motor Run/Stop

The motor run/stop feature allows the stopping of a motor by shorting out the bottom drives of the three phases. A low at this input allows the motor to run, while a high (open) input does not allow motor operation and if operating causes rapid deceleration.

Motor Direction

The motor direction feature allows the changing of the rotation of the motor. This input should not be changed while motion is in progress. A high (open) input causes the motor to turn in the CW direction, while a low at this input causes the motor to turn in the CCW direction.

Note: Avoid changing the direction of rotation when the motor is already running any one direction.

The following instructions must be followed to prevent permanent drive failure due to over-current conditions that exist in dynamic direction reversals of the motor:

1. Stop the motor by grounding the RUN/STOP input
2. Wait for at least 500mS
3. Change the direction with the DIRECTION input
4. Run the motor by removing ground signal on the RUN/STOP input

Speed Adjust Setting

The speed may be varied byth espeed potentiometer. If a voltage other than 0V to 5V is needed to control the speed of the motor, contact Anaheim Automation for custom tuning of the Vcontrol input.

Heating Considerations

The temperature of the heat sink should never be allowed to rise above 70° Celsius. If necessary, mount the unit to an additional heat sink or air should be blown across the heat sink to maintain suitable temperatures.

Dimensions / Hookup

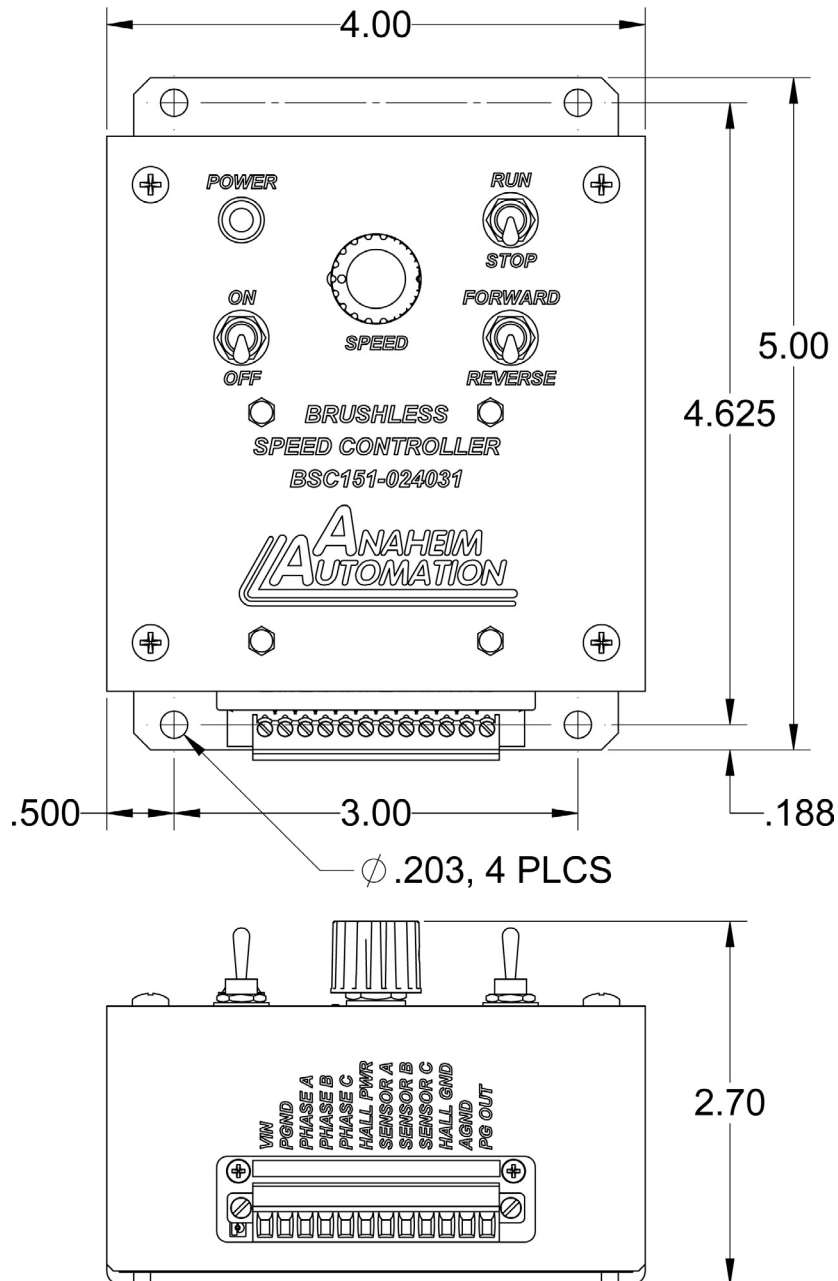

All units are in inches

Internal Wiring Diagram

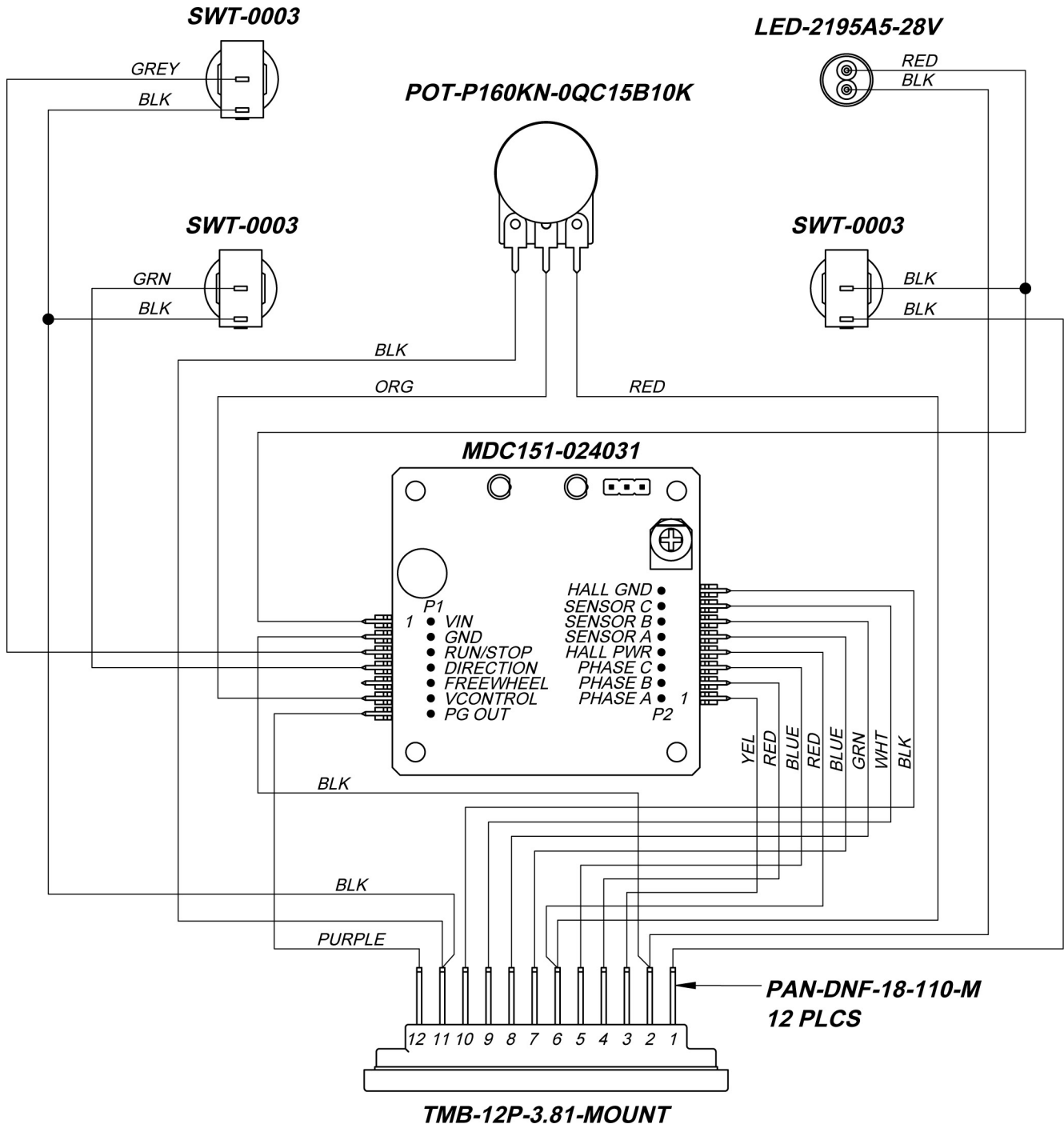

COPYRIGHT

Copyright 2014 by Anaheim Automation. All rights reserved. No part of this publication may be reproduced, transmitted, transcribed, stored in a retrieval system, or translated into any language, in any form or by any means, electronic, mechanical, magnetic, optical, chemical, manual, or otherwise, without the prior written permission of Anaheim Automation, 910 E. Orangefair Lane, Anaheim, CA 92801.

DISCLAIMER

Though every effort has been made to supply complete and accurate information in this manual, the contents are subject to change without notice or obligation to inform the buyer. **In no event will Anaheim Automation be liable for direct, indirect, special, incidental, or consequential damages arising out of the use or inability to use the product or documentation.**

Anaheim Automation's general policy does not recommend the use of its' products in life support applications wherein a failure or malfunction of the product may directly threaten life or injury. Per Anaheim Automation's Terms and Conditions, the user of Anaheim Automation products in life support applications assumes all risks of such use and indemnifies Anaheim Automation against all damages.

LIMITED WARRANTY

All Anaheim Automation products are warranted against defects in workmanship, materials and construction, when used under Normal Operating Conditions and when used in accordance with specifications. This warranty shall be in effect for a period of twelve months from the date of purchase or eighteen months from the date of manufacture, whichever comes first. **Warranty provisions may be voided if products are subjected to physical modifications, damage, abuse, or misuse.**

Anaheim Automation will repair or replace at its' option, any product which has been found to be defective and is within the warranty period, provided that the item is shipped freight prepaid, with previous authorization (RMA#) to Anaheim Automation's plant in Anaheim, California.

TECHNICAL SUPPORT

If you should require technical support or if you have problems using any of the equipment covered by this manual, please read the manual completely to see if it will answer the questions you have. If you need assistance beyond what this manual can provide, contact your Local Distributor where you purchased the unit, or contact the factory direct.

ANAHEIM AUTOMATION