

BLD75-1 Bilevel Step Motor Driver

User's Guide



ANAHEIM AUTOMATION

910 East Orangefair Lane, Anaheim, CA 92801
e-mail: info@anaheimautomation.com

(714) 992-6990 fax: (714) 992-0471
website: www.anaheimautomation.com

Features

- Unipolar Operation
- 10 Amps per Phase Operating Current (Kick Current)
- 7 Amps per Phase Standstill Current
- 70 Volt Operation
- Short Circuit, Open Circuit, High Voltage, Low Voltage and Over Temperature Fault Detection
- Inputs accept 24VDC signals
- Motor ON/OFF Input
- Half-Step and Full-Step Operations
- Bilevel Driver Operation
- Fault LED, and Fault Output
- Detachable Terminal Block
- Compact and Rugged
- **Available in Driver Packs**

What is a Step Motor Driver?

A step motor driver is a device that takes input signals (usually Clock and Direction) and translates this information into phase currents in the motor. Each time the step motor driver receives a pulse, the step motor moves one step. If the driver receives 200 pulses, the motor moves 200 steps. The motor steps at the same frequency as the clock pulses.

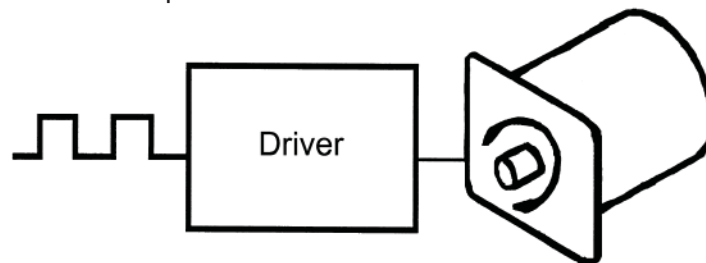

FIGURE 1: Step Motor Driver

General Description

The BLD75 is a step motor driver that can drive motors rated from 1 to 7 amps/ phase (unipolar rating). It can handle 6 lead and 8 lead motors. This driver features a unipolar bilevel (or dual voltage) drive technique with short circuit, open circuit, over and under voltage, and over temperature detection (with a Fault LED and output). A transformer is required to power up the driver.

Bilevel Drive

The basic function of a motor driver is to provide the rated motor phase current to the motor windings in the shortest possible time. The bilevel driver uses a high voltage to get a rapid rate of current rise in the motor windings in the least amount of time. When reaching the present trip current, the driver turns off the high voltage and sustains the current from the low voltage supply.

Half-Step/Full-Step

Users have a choice of full-step operation or half-step operation. Full-step operation occurs by energizing two phases at a time, rotating a typical motor 1.8 degrees per step. Half-step operation occurs by alternately energizing one, and then two, phases at a time, rotating the motor 0.9 degrees per step. Full-step operation is suggested for applications that specifically require that mode, such as when retrofitting existing full-step systems.

Clock Modes

The BLD75 has two clock options: Clock and Direction, or Dual Clock operation. Jumper JP2 is used to select the clock option. Basically JP2 selects Terminal 5 as either the Direction input or the CCW input.

With the Clock and Direction option (most common option), clock pulses applied to the Clock input (Terminal 6) cause the motor to step. The direction of the motor is determined by the logic level of the Direction input (Terminal 5). Jumper JP2 must be in the “2-3” position for this mode (see Figure 4 and Table 1). Physical direction also depends on the motor wiring.

With the Dual Clock option, clock pulses applied to the Clock input (Terminal 6) cause the motor to step in the clockwise direction. Clock pulses applied to the CCW input (Terminal 5) cause the motor to step in the counterclockwise direction. Jumper JP2 must be in the “1-2” position for this mode.

Either positive or negative going pulses may be used by setting jumpers in the appropriate position (see Table 1). To determine which setting to use, first consider the type of clock pulse output on the pulse generator or indexer (controller). If the clock output on the controller is open-collector type (sinking), then use the negative going jumper setting. If the clock output on the controller is a pnp or p-channel (sourcing) type, then use the positive going jumper setting. If the clock output on the controller is a TTL/CMOS type (totem pole), then either setting will work; but the jumper setting should be chosen based on the level of the clock output when the controller is not pulsing, then use the negative going jumper setting.

The clock inputs (Clock and CCW) are pulled up to +5VDC through a 10K resistor for negative going clock inputs; or pulled down to 0VDC through a 10K ohm resistor for positive going clock inputs. The pullups/pulldowns are followed by an RC filter. See Figure 2 and Figure 3.

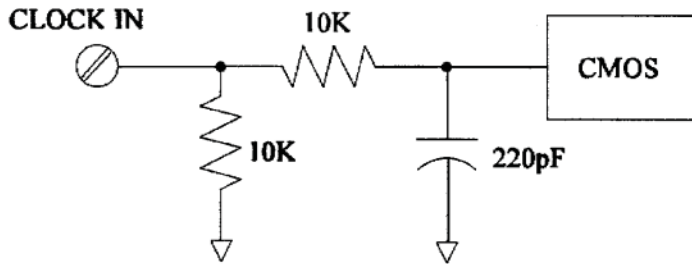

Figure 2: Sourcing Clock Input

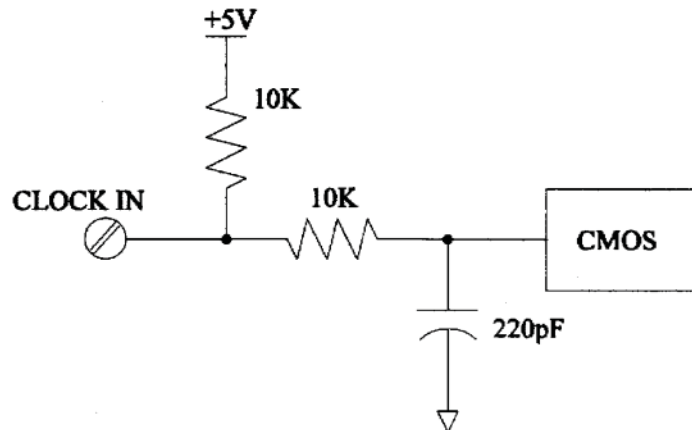

Figure 3: Sinking Clock Input

Motor On/Off Input

The motor on/off input allows de-energizing a motor without disturbing the positioning logic. After re-energizing the motor, a routine can continue. This reduces motor heating and conserves power, especially in a applications where motors are stopped for long periods and no holding torque is required. If holding torque is required (such as when lifting a load vertically), then the motor must stay energized.

Jumper Functions/Locations

Function	JP1	JP2	JP3
Negative Going Clocks	1-2	X	X
Positive Going Clocks	2-3	X	X
Terminal 5 = CCW	X	1-2	X
Terminal 5 = Direction	X	2-3	X
Low Voltage Fault Detection Enabled	X	X	1-2
Low Voltage Fault Detection Disable	X	X	2-3
Standard Product	1-2	2-3	2-3

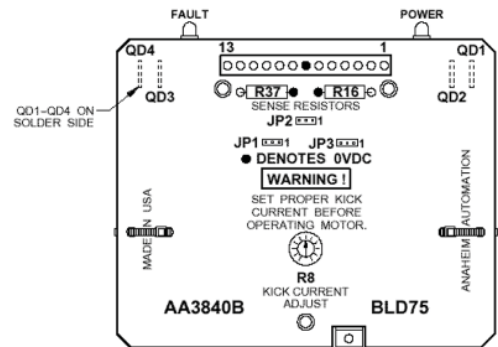
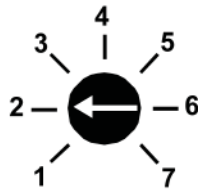

Figure 4: Jumper Location Drawing

Adjusting Kick Current

By following the instructions on the cover, use a small screwdriver to adjust the potentiometer. Line up the potentiometer's arrow to the number corresponding to the motors rated current (amps/phase).



Example 1: 23D104 Motor, Set to 2.0A.

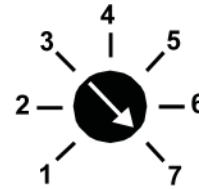

Example 2: 34D314 Motor, Set to 7.0A.

Fault Protection

There are five types of fault detection. When a fault is detected, the driver turns off the motor current, the red fault LED indicates which type of fault occurred and the Fault Output (pin 10) goes low. This output is able to stand off 50V and sink 50mA. Refer to the table below for LED fault indications.

# of LED Blinks	Fault Condition
1	Short or Over Current
2	Open Motor or Connection
3	High Voltage Too High
4	Low Voltage Too Low
5	Over Temperature

If a fault occurs, reset the fault by applying a logic "0" to the Reset Fault Input (pin 4) for at least 100ms or by cycling power off for at least 15 seconds. After resetting, try to run the motor again. If the driver continues to fault, check the conditions listed in the troubleshooting section on page 11.

Motor Connections

Figure 5 is a hookup diagram for typical BLD75 driver applications. The input signal connection must be separate from motor connections and all other possible sources of interference.

IMPORTANT NOTE: When the motor cable between the driver and the step motor extends beyond 25 feet, consult the factory.

Wiring Diagram

The wiring diagram in Figure 5 shows the BLD75 with the AA2791 Transformer. For wiring with the AA2793 Transformer, refer to figure 9

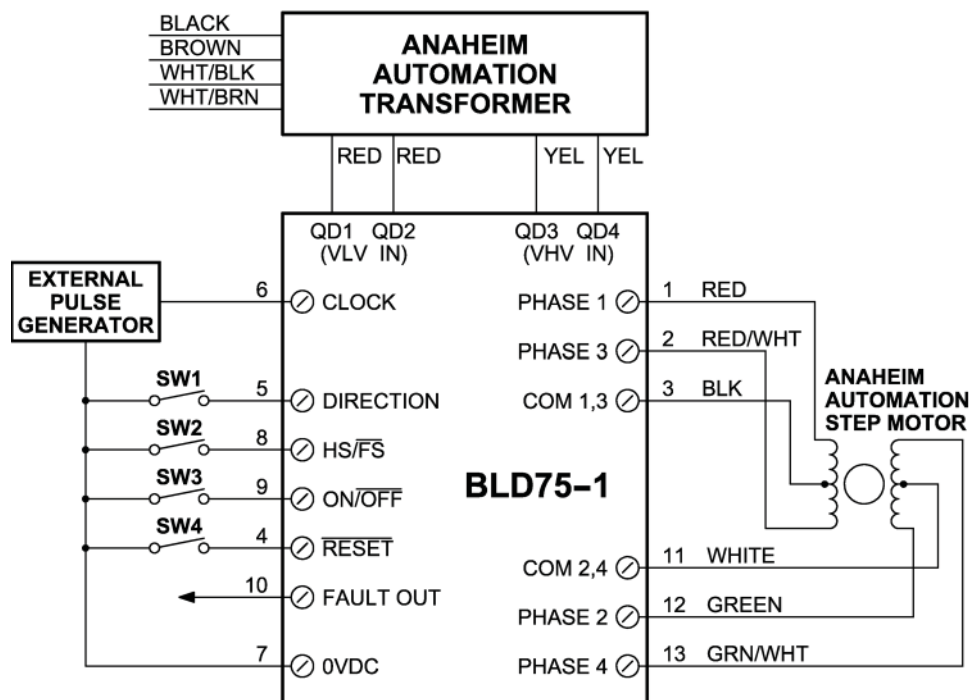

Power Supply Requirements

The BLD75 must be powered by a recommended Anaheim Automation transformer. The AA2791 transformer and the AA2793 transformer are the most commonly used and are both rated for 300VA. These transformers have a high voltage winding, a low voltage winding, and a logic voltage winding. The AA2793 has two high voltage windings and two low voltage windings for powering two BLD75's. The high voltage winding (yellow) and low voltage winding (red) plug into the quick disconnects on the back of the BLD75 (see hookup diagram in Figure 5). The logic voltage winding (orange) is used to power up optional controllers. When using one of these transformers, the nominal low-voltage is 5.0 volts and the nominal high voltage is 60V. The transformer voltages are shown in Figures 7 and 8; the physical dimensions are shown in Figure 6. For other transformers, refer to ordering information chart or contact the factory.

Transformer Drawings

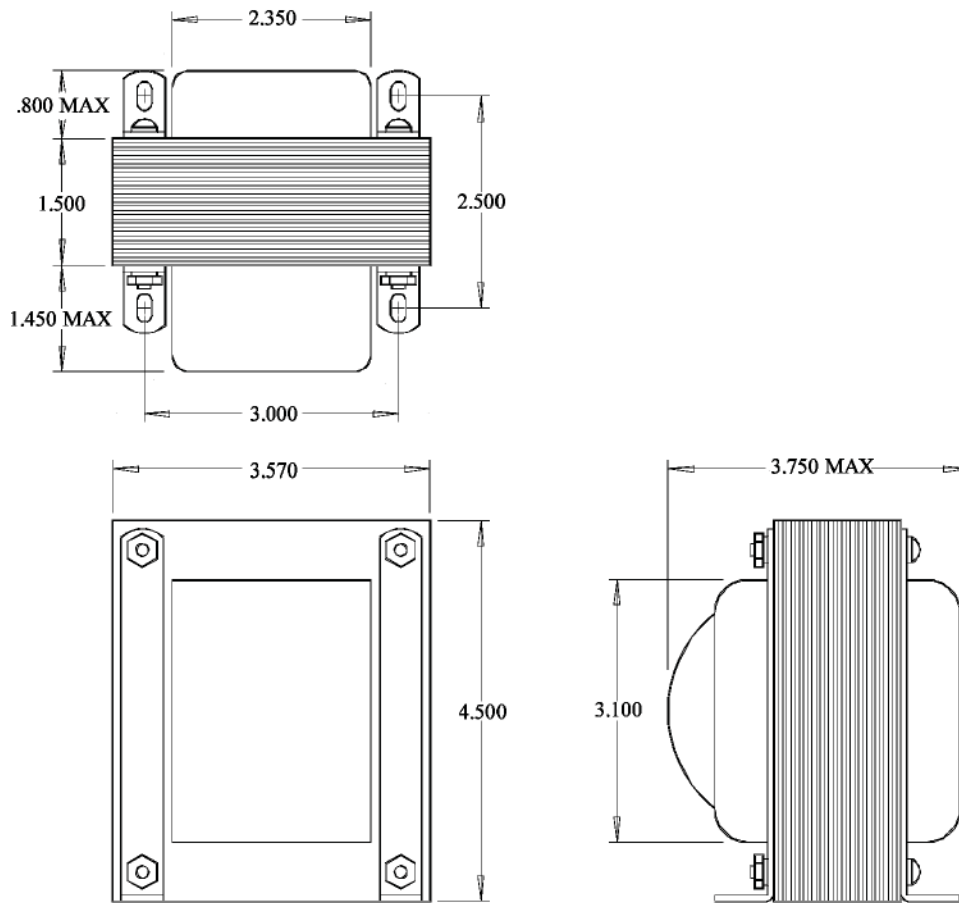

Figure 6: Transformer Dimensions

Note: The AA2793 transformer is the same physical size as the AA2791, but it has two sets of secondary windings (to power two drivers) and a dual primary winding for 115/230V operation.

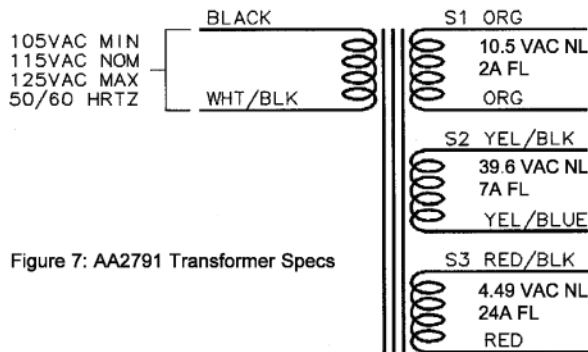

Figure 7: AA2791 Transformer Specs

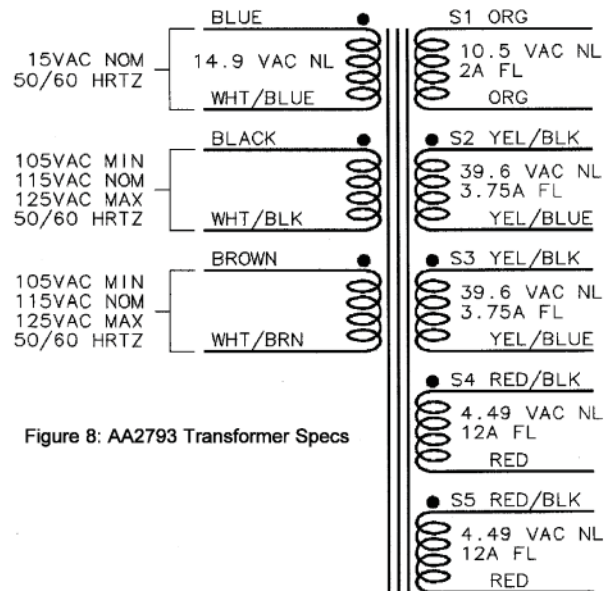

Figure 8: AA2793 Transformer Specs

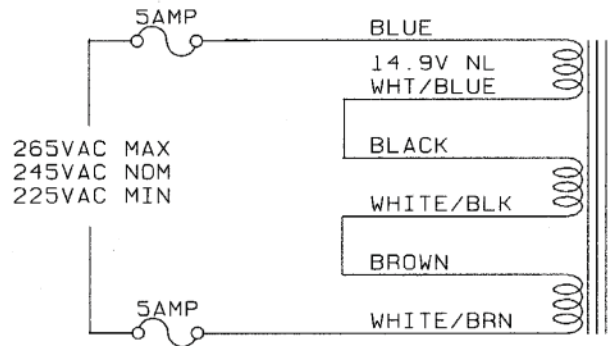
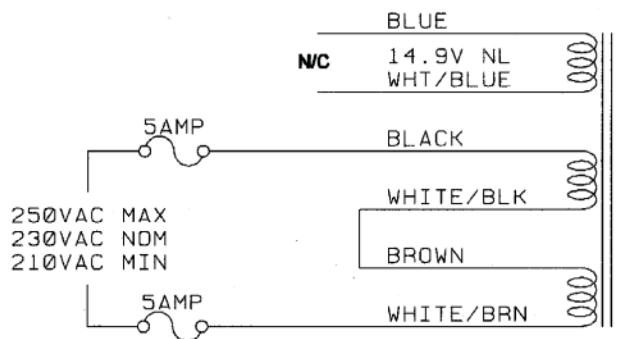
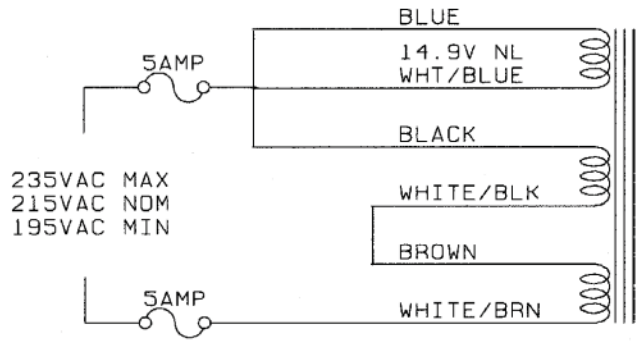
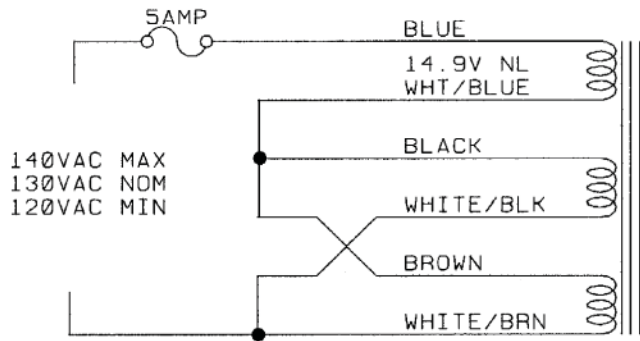
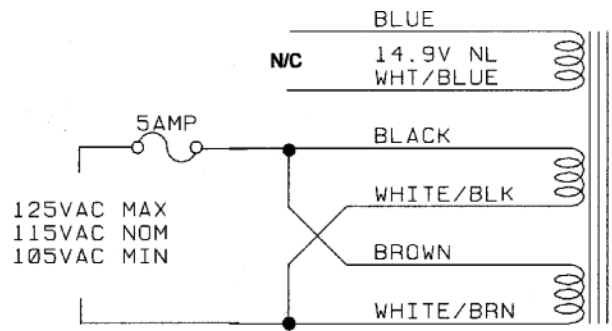
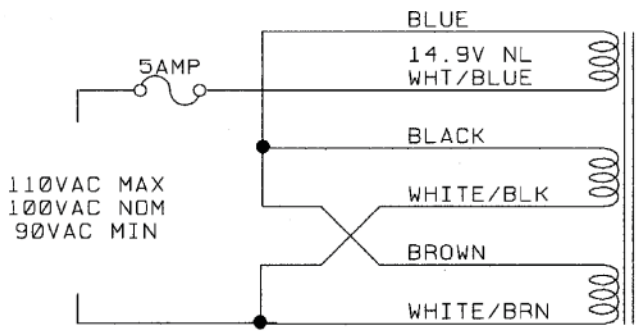
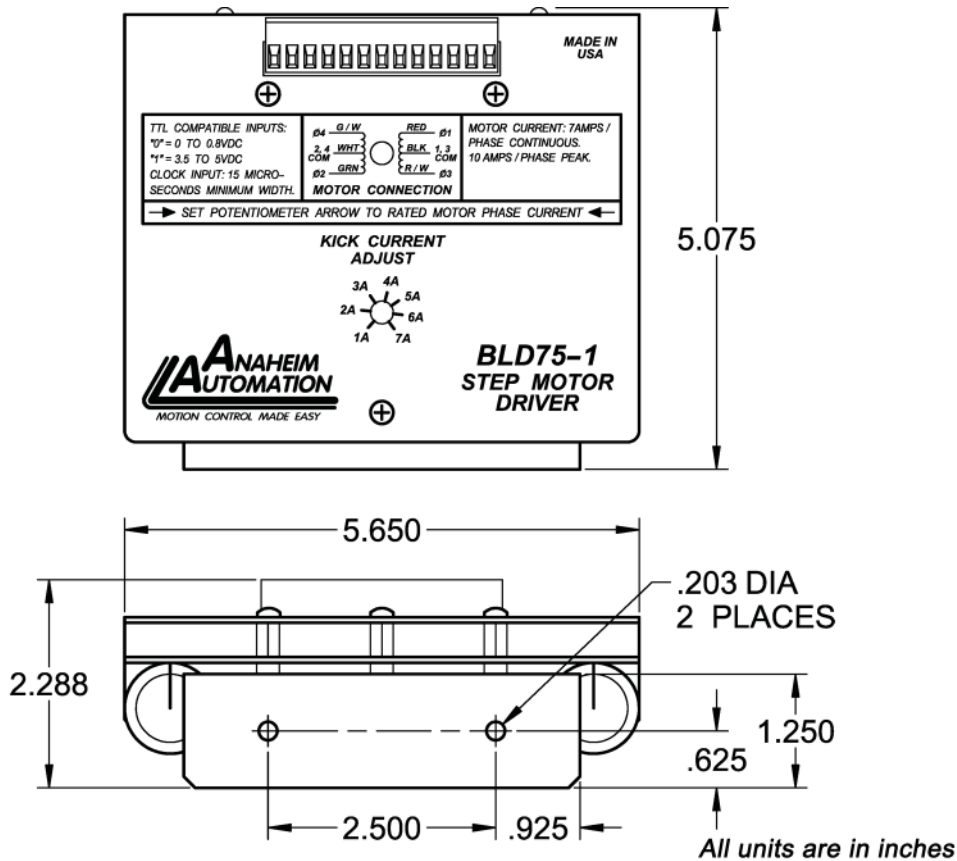

Figure 9: Wiring for different line voltages for transformers with a 90-265VAC input.

Dimension Drawings



Ordering Information Chart

Part Number	Description
AA2791B	Transformer, Single Output Secondaries, 300VA, 115VAC in (Recommended)
AA2793	Transformer, Dual output Secondaries, 300VA 90-265VAC in
AA2977	CE Approved Transformer, Single Output Secondaries, 300VA, 90-265VAC in
AA3075	Transformer, Dual output Secondaries, 400VA, 90-265VAC in
AA3361	Transformer, Dual output Secondaries, 500VAC, 90-265VAC in
CBL-16AWG-06C	Motor Cable, 6 Conductor, Shield, 16 Gauge, Sold per linear foot
CBL-18AWG-06C	Motor Cable, 6 Conductor, Shielded, 18 Gauge, Sold per linear foot

13 Pin Terminal Description

Terminal #	Description	6 Lead Motor	8 Lead Motor
1	Motor, Phase 1	Red	Orange
2	Motor, Phase 3	Red/White	Black
3	Motor, Common 1 & 3	Black	Orange/White & Black White
4	Fault Reset	---	---
5	Direction (CCW)	---	---
6	Clock (CW)	---	---
7	OVDC	---	---
8	Half-Step/Full Step	---	---
9	On/Off	---	---
10	Fault Output	---	---
11	Motor, Common 2 & 4	White	Red/White & Yellow/White
12	Motor, Phase 2	Green	Red
13	Motor, Phase 4	Green/White	Yellow

Motor Compatibility - Sample List, more motors available

Standard Motors - D Series

Part #	Unipolar Rating
23D104_	2.0A
23D108_	4.0A
23D209_	4.5A
23D309_	4.5A
34D106_	3.0A
34D109_	4.5A
34D207_	3.5A
34D213_	6.5A
34D314_	7.0A
42D112_	6.0A
42D212_	6.0A

High Torque Motors - Y Series

Part #	Unipolar Rating
23Y206_	3.0A
23Y210_	5.0A
23Y306_	3.0A
23Y310_	5.0A
34Y108_	4.0A
34Y112_	6.0A
34Y207_	3.5A
34Y214_	7.0A
34Y307_	3.5A
34Y314_	7.0A
42Y112_	6.0A

Add suffix "S" for single-ended shaft, or suffix "D" for double-ended shaft.

Notes: Other motors not listed above may be compatible with this driver.

Anaheim Automation carries a full-line of standard and high torque step motors. Contact the factory regarding compatibility. See back cover for speed/torque curves.

Specifications

Control Inputs (All): (Pins 5, 6, 8, 9)

TTL-Compatible

Logic "0" - 0 to 0.8 V

Logic "1" - 3.5 to 24.0V

Fault Reset: (Pin 4)

Logic "1" (open) - Driver enabled and Fault detection enabled

Logic "0" - Resets a Fault condition (driver is disabled when this input is low). This input must be held low for at least 100ms.

Clock Inputs: (Pins 5 and 6)

Pulse required; 15 microseconds minimum. The clock input is pulled up/down internally to +5VDC/0VDC through a 10k ohm resistor, based upon JP2 selection.

Direction Control: (Pin 5)

Logic "1" (open) - CW

Logic "0" - CCW

Excitation Mode Select: (Pin 8)

Logic "1" (open) - Half-step

Logic "0" - Full-step

Power ON/OFF: (Pin 9)

Logic "1" (open) - motor current on

Logic "0" - motor current off

Fault Output: (Pin 10)

This output is an open drain output. Conducting (pulled to ground) with a fault, open under normal operation. 50V Stand Off, with current sink of 50mA Max.

Output Current Rating: (Pins 1, 2, 3, 11, 12, and 13)

10 Amps/phase maximum operating current, 7.0 Amps/phase maximum standstill current, over the operating voltage and temperature range. Motor phase ratings of 1.0 Amp minimum are required to meet the minimum kick level.

Power Requirement:

Anaheim Automation recommended transformer. Refer to ordering information chart.

Operating Temperature: 0 to 60 degrees C

It is recommended that the aluminum driver baseplate be mounted on a larger aluminum plate, or similar heat-conducting structure, whenever possible. This will prevent the driver baseplate from overheating and degrading driver reliability. **Fan cooling is also recommended to eliminate hot spots on the heat sink.**

Fusing: A 5 Amp Fast Blow fuse in series with the primary winding of the transformer is required.

Troubleshooting

If a fault occurs, reset the fault by applying a logic “0” to the Reset Fault Input (pin 4) for at least 100ms or by cycling power off for at least 15 seconds. After resetting, try to run the motor again. If the driver continues to fault, check the conditions listed below.

Short (One Blink)

This indicates that the driver or motor has a phase shorted or there is a “short” in the motor cable or wiring. Check the motor and the physical wiring for shorts. If the driver continues to sense shorts after the motor and wiring are determined to be accurate, then the output transistors should be checked using a multimeter as follows:

1. Set the multimeter to diode test.
2. Place the red lead on the ground (pin 7).
3. Touch the black lead to each phase (pins 1, 2, 12, and 13).
4. This should give readings between 0.450V and 0.550V.
5. If any readings are significantly less than 0.450V, then the unit has been damaged.

Open (Two Blinks)

This indicates that there is an “open” or intermittent connection in one of the motor wires. Check motor and the wiring for opens. Another condition that may cause this type of fault, is when a large motor is ramped down too quickly and it loses its position (stalls).

High Voltage Too High (Three Blinks)

This indicates that the input voltage of the transformer is too high. Check the input voltage of the transformer to see if it is within the specified range.

Low Voltage Too Low (Four Blinks)

This indicates that there is an excess amount of current being pulled from the driver or the input voltage to the transformer is too low to provide the amount of current needed by the low voltage winding. Check the input voltage of the transformer to see if the voltage is within the specified range.

Over Temperature (Five Blinks)

This is caused by the heat sink reaching a temperature of 80°C. Make sure proper ventilation or an additional heat sink is provided so the temperature does not reach this level.

If a factory repair is required, contact Anaheim Automation for a RMA#
(800) 345-9401 or (714) 992-6990

COPYRIGHT

Copyright 2007 by Anaheim Automation. All rights reserved. No part of this publication may be reproduced, transmitted, transcribed, stored in a retrieval system, or translated into any language, in any form or by any means, electronic, mechanical, magnetic, optical, chemical, manual, or otherwise, without the prior written permission of Anaheim Automation, 910 E. Orangefair Lane, Anaheim, CA 92801.

DISCLAIMER

Though every effort has been made to supply complete and accurate information in this manual, the contents are subject to change without notice or obligation to inform the buyer. **In no event will Anaheim Automation be liable for direct, indirect, special, incidental, or consequential damages arising out of the use or inability to use the product or documentation.**

Anaheim Automation's general policy does not recommend the use of its' products in life support applications wherein a failure or malfunction of the product may directly threaten life or injury. Per Anaheim Automation's Terms and Conditions, the user of Anaheim Automation products in life support applications assumes all risks of such use and indemnifies Anaheim Automation against all damages.

LIMITED WARRANTY

All Anaheim Automation products are warranted against defects in workmanship, materials and construction, when used under Normal Operating Conditions and when used in accordance with specifications. This warranty shall be in effect for a period of twelve months from the date of purchase or eighteen months from the date of manufacture, whichever comes first. **Warranty provisions may be voided if products are subjected to physical modifications, damage, abuse, or misuse.**

Anaheim Automation will repair or replace at its' option, any product which has been found to be defective and is within the warranty period, provided that the item is shipped freight prepaid, with previous authorization (RMA#) to Anaheim Automation's plant in Anaheim, California.

TECHNICAL SUPPORT

If you should require technical support or if you have problems using any of the equipment covered by this manual, please read the manual completely to see if it will answer the questions you have. If you need assistance beyond what this manual can provide, contact your Local Distributor where you purchased the unit, or contact the factory direct.

Open Loop Torque Speed Curve

BLD75 Series with 23L004 and 23L108

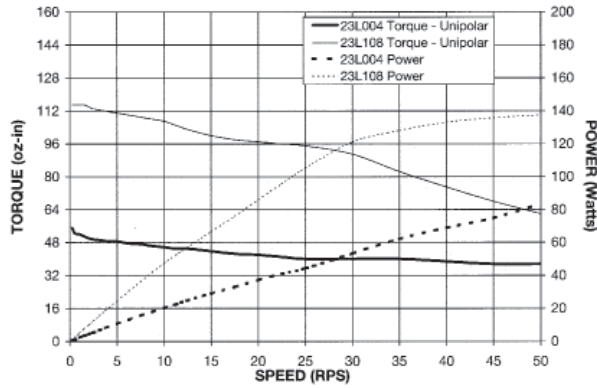

BLD75 Series with 23L210 and 23L310

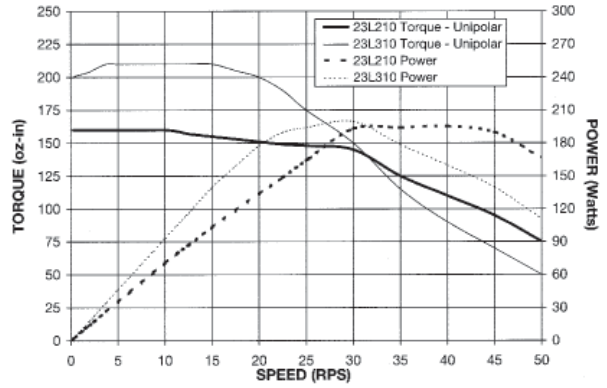

BLD75 Series with 23D309 and 34D109

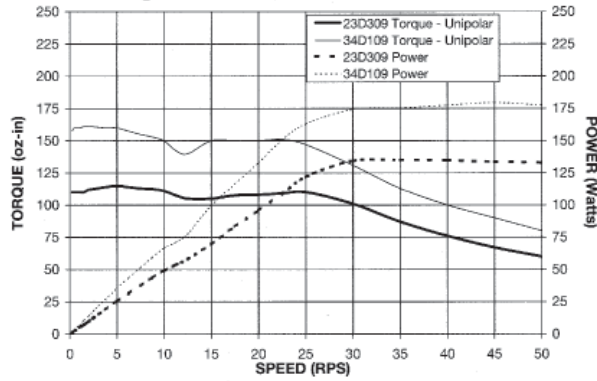

BLD75 Series with 34D213 and 34D314

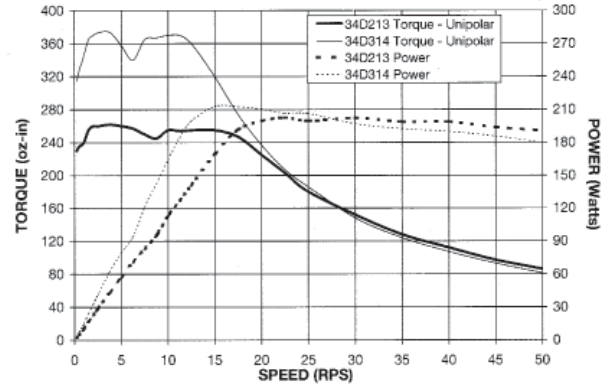

BLD75 Series with 34N112 and 34N214

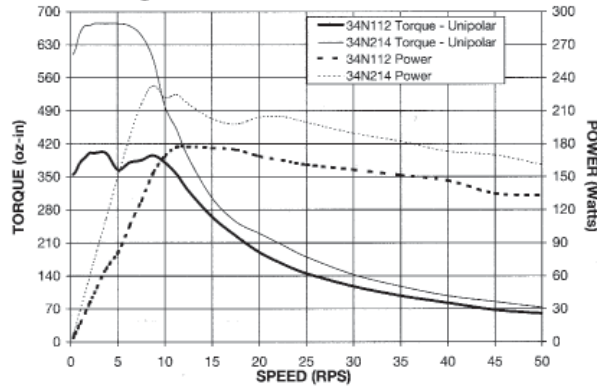

BLD75 Series with 42N214 and 42K214

