

# 17MD Series - Integrated Stepper Motors/Drivers



## FEATURES

- **NEMA 17 Step Motor and Microstep Driver**
- **High Torque - Up to 62 oz-in**
- **Eliminates Motor Wires**
- **12-24VDC Power Requirement**
- **Compact Package**
- **Microstep Divisors of 8, 4, 2, or Full Step**
- **Ideal for Precise Positioning**
- **0.225° Resolution per step**
- **Efficient and Durable**
- **Long Life Expectancy**
- **RoHS Compliant**



## DESCRIPTION

The 17MD Series has a compact construction that implements a microstepping driver and a NEMA 17 stepper motor in one streamline package. With the two parts combined into one casing, the need to include motor wires has been eliminated. The high-torque stepper motor can generate up to 62 oz-in of torque. The microstepping driver will operate with voltage from 12VDC to 24VDC. The inputs are capable of running from either open collector or TTL level logic outputs. The microstepping driver features resolutions from 200 - 1600 steps/revolution, providing smooth rotary operation. The 17MD Series comes in a single shaft version with three different motor stack lengths, allowing for varying amounts of start-up torque and inertia. The 17MD Series features built in over temperature and short circuit shut down. It also has automatic 70% reduction in current after clock pulses stop being received, and status LED's to indicate power on (green LED) and clocks being received (yellow LED).

**A power supply is required (purchased separately).**

## SPECIFICATIONS

Model #	Frame Size	Bipolar Torque (oz-in)	Rotor Inertia (oz-in-sec <sup>2</sup> )	Weight (lbs)	"L" Length (in)
17MD102S-00	17	31	0.00050	0.54	2.22
17MD202S-00	17	50	0.00076	0.72	2.45
17MD302S-00	17	62	0.00096	0.87	2.77

L010412

DIMENSIONS

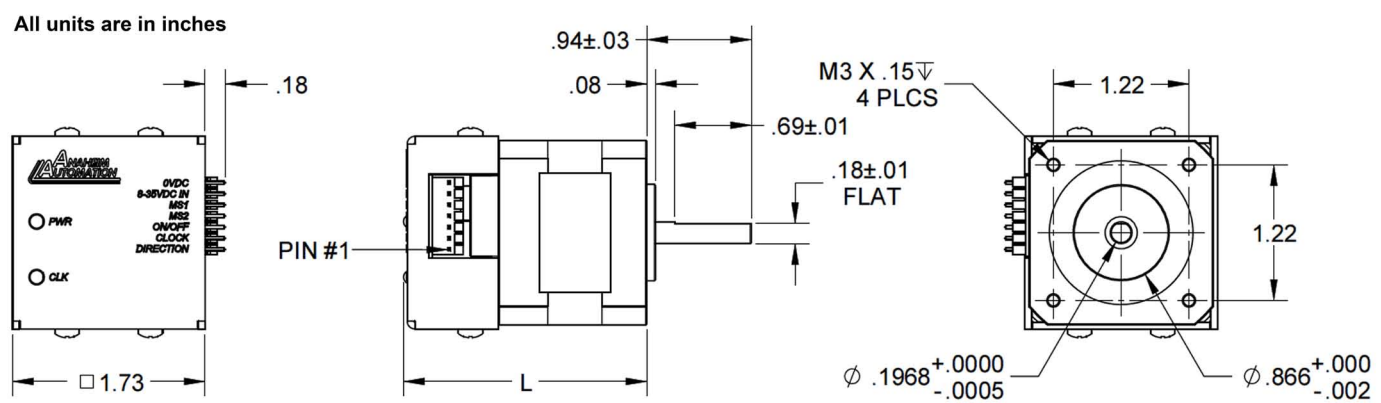

WIRING INFORMATION

Terminal Block Pin	Description	CBL-AA4031 Wire Color
1	Direction	Brown
2	Clock	Red
3	On/Off	Orange
4	MS2	Yellow
5	MS1	Green
6	8VDC-35VDC	Blue
7	0VDC (Gnd)	Violet

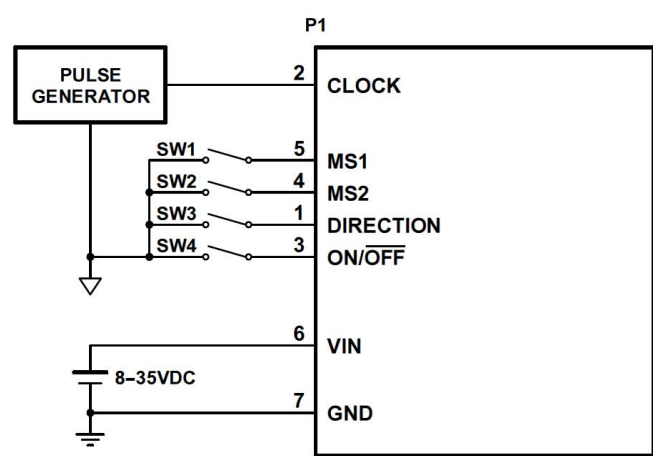

**17MD SERIES  
(SINKING INPUTS)**

SPECIFICATIONS

Power Input:	8 - 35 VDC	Step Resolution:	200, 400, 800 and 1600 steps/rev
Step Angle:	1.8°	Insulation Resistance:	100M ohm Min., 500 VDC
Step Angle Accuracy:	±5%	Dielectric Strength:	500 VAC for one minute
Resistance Accuracy:	±10%	Shaft Radial Play:	0.02 Max. (1lbs load)
Inductance Accuracy:	±20%	Shaft Axial Play:	0.08 Max. (1lbs load)
Temperature Rise:	80°C Max. (rated current, 2 Phase on)	Max. Radial Force:	6.3lbs (0.79 in from the flange)
Ambient Temperature:	-20°C to +50°C	Max. Axial Force:	2.25lbs