

ETS Series AC Servo User's Manual

(Version: V1.03)



ESTUN AUTOMATION TECHNOLOGY CO., LTD

— Total Solution Supplier

Copyright © 2014 ESTUN AUTOMATION TECHNOLOGY CO., LTD

All rights reserved. No part of this publication may be reproduced, stored in a retrieval system, or transmitted, in any form, or by any means, mechanical, electronic, photocopying, recording, or otherwise, without the prior written permission of ESTUN. No patent liability is assumed with respect to the use of the information contained herein.

About this manual

- This manual describes the following information required for designing and maintaining ETS series servo drives.

- Specification of the servo drives and servomotors.
- Procedures for installing the servo drives and servomotors.
- Procedures for wiring the servo drives and servomotors.
- Procedures for operating of the servo drives.
- Procedures for using the panel operator.
- Communication protocols.
- Ratings and characteristics.

- Intended Audience:

- Those designing ETS series servo drive systems.
- Those installing or wiring ETS series servo drives.
- Those performing trial operation or adjustments of ETS series servo drives.
- Those maintaining or inspecting ETS series servo drives.

Safety Precautions

- Do not connect the servomotor directly to the local electrical network.

Failure to observe this may result in damage to servomotor.

- Do not plug or unplug connectors from servo drive when power is on.

Failure to observe this may result in damage to servo drive and servomotor.

- Please note that even after power is removed, residual voltage still remains in the capacitor inside the servo drive. If inspection is to be performed after power is removed, please wait 5 minutes to avoid risk of electrical shock.

- Keep servo drives and other devices separated by at least 10mm.

The servo drive generates heat. Install the servo drive so that it can radiate heat freely. When installing servo drives with other devices in a control panel, provide at least 10mm space between them and 50mm space above and below them. Please install servo drives in an environment free from condensation, vibration and shock.

- Perform noise reduction and grounding properly.

Please comply with the following instructions to avoid noise generated by signal lines.

1. Separate high-voltage cables from low-voltage cables.
2. Use cables as short as possible.
3. Single point grounding is required for the servomotor and servo drive (grounding resistance 100Ω or below).
4. Never use a line filter for the power supply in the circuit.

- Use a fast-response type ground-fault interrupter.

For a ground-fault interrupter, always use a fast-response type or one designed for PWM inverters. Do not use a time-delay type.

- Do not make any extreme adjustments or setting changes of parameters.

Failure to observe this caution may result in injury or damage to the product due to unstable operation.

- The servomotor cannot be operated by turning the power on and off.

Frequently turning the power ON and OFF causes the internal circuit elements to deteriorate, resulting in unexpected problems. Always start or stop the servomotor by using reference pulses.

—Contents—

About this manual.....	- 2 -
Safety Precautions.....	- 3 -
Chapter 1.....	- 7 -
Checking Products and Parts Names.....	- 7 -
1.1 Checking Products on Delivery.....	- 7 -
1.1.1 Servomotor.....	- 7 -
1.1.2 Servo drive.....	- 9 -
1.2 Part Names.....	- 11 -
1.2.1 Servomotor.....	- 11 -
1.2.2 Servo drive.....	- 11 -
Chapter 2.....	- 13 -
Installation.....	- 13 -
2.1 Servomotor.....	- 13 -
2.1.1 Storage.....	- 13 -
2.1.2 Installation Sites.....	- 13 -
2.1.3 Installation Alignment.....	- 14 -
2.1.4 Installation Orientation.....	- 14 -
2.1.5 Handling Oil and Water.....	- 14 -
2.1.6 Cable Tension.....	- 15 -
2.1.7 Install to the Client.....	- 15 -
2.2 Servo Drive.....	- 15 -
2.2.1 Storage.....	- 15 -
2.2.2 Installation Sites.....	- 15 -
2.2.3 Installation Orientation.....	- 16 -
2.2.4 Installation Method.....	- 16 -
Chapter 3.....	- 18 -
Wiring.....	- 18 -
3.1 Main Circuit Wiring.....	- 18 -
3.1.1 Typical Main Circuit Wiring Examples.....	- 19 -
3.1.2 Names and Functions of Main Circuit Terminals.....	- 20 -
3.2 I/O Signals.....	- 21 -
3.2.1 Examples of I/O Signal Connections.....	- 21 -
3.2.2 I/O Signal Connector (CN1_A/CN1_B/CN1_C) Terminal Layout.....	- 22 -
3.2.3 I/O Signal Names and Functions.....	- 24 -
3.2.4 Interface Circuit.....	- 25 -
3.3 Wiring Encoders.....	- 26 -
3.3.1 Connecting an Encoder(CN2_A/ CN2_B/ CN2_C).....	- 26 -
3.3.2 Encoder Connector(CN2_A/ CN2_B/ CN2_C) Terminal Layout.....	- 26 -
3.4 Communication Connection (CN3/CN4).....	- 27 -
3.5 Standard Wiring Example.....	- 28 -
3.6 Standard Wiring Example.....	- 29 -
3.7 Wiring for Noise Control.....	- 31 -
3.7.1 Noise Control.....	- 31 -

3.7.2 Precautions on Connecting Noise Filter.....	- 32 -
Chapter 4.....	- 35 -
Operation.....	- 35 -
4.1 Trial Operation.....	- 35 -
4.1.1 Trial Operation for Servomotor Without Load.....	- 37 -
4.1.2 Trial Operation for Servomotor without Load from Host Reference.....	- 39 -
4.1.3 Trial Operation with the Servomotor Connected to the Machine.....	- 41 -
4.1.4 Trial Operation for Servomotor with Brakes.....	- 42 -
4.2 Control Mode Selection.....	- 42 -
4.3 Setting Common Basic Functions.....	- 43 -
4.3.1 Setting the Servo ON Signal.....	- 43 -
4.3.2 Switching the Servomotor Rotation Direction.....	- 44 -
4.3.3 Setting the Overtravel Limit Function.....	- 45 -
4.3.4 Setting for Holding Brakes.....	- 48 -
4.4 Operating Using Speed Control with Internally Set Speed.....	- 51 -
4.4.1 Setting Parameters.....	- 51 -
4.4.2 Soft Start.....	- 52 -
4.4.3 Speed Reference Filter Time Constant.....	- 52 -
4.4.4 S-curve Risetime.....	- 53 -
4.4.5 Encoder Signal Output.....	- 53 -
4.4.6 Speed coincidence output.....	- 55 -
4.4.7 Speed control (contact reference).....	- 56 -
4.5 Operating Using Position Control.....	- 58 -
4.5.1 Basic Setting in Position Control.....	- 58 -
4.5.2 Setting the Clear Signal.....	- 60 -
4.5.3 Setting the Electronic Gear.....	- 60 -
4.5.4 Smoothing.....	- 64 -
4.5.5 Low Frequency Vibration Suppression.....	- 65 -
4.5.6 Positioning Completion Output Signal.....	- 67 -
4.5.7 Reference Pulse Inhibit Function (INHIBIT).....	- 68 -
4.5.8 Position Control (contact reference).....	- 68 -
4.5.9 Position Homing Control (Homing Function).....	- 72 -
4.6 Limiting Torque.....	- 75 -
4.6.1 Internal Torque Limit.....	- 75 -
4.6.2 External Torque Limit.....	- 76 -
4.7 Other Output Signals.....	- 77 -
4.7.1 Servo alarm output.....	- 77 -
4.7.2 Others.....	- 77 -
4.8 Online Autotuning.....	- 79 -
4.8.1 Online Autotuning.....	- 79 -
4.8.2 Online Autotuning Procedure.....	- 79 -
4.8.3 Setting Online Autotuning.....	- 80 -
4.8.4 Machine Rigidity Setting for Online Autotuning.....	- 81 -
Chapter 5.....	- 82 -
Panel Operator.....	- 82 -

5.1 Basic Operation.....	- 82 -
5.1.1 Functions on Panel Operator.....	- 82 -
5.1.2 Switch the number of Axis.....	- 82 -
5.1.3 Basic Mode Selection.....	- 83 -
5.1.4 Status Display Mode.....	- 83 -
5.1.5 Operation in Parameter Setting Mode.....	- 85 -
5.1.6 Operation in Monitor Mode.....	- 86 -
5.2 Operation in Utility Function Mode.....	- 89 -
5.2.1 Alarm Traceback Data Display.....	- 89 -
5.2.2 Parameter Settings Initialization.....	- 90 -
5.2.3 Operation in JOG Mode.....	- 91 -
5.2.4 Offset-adjustment of Servomotor Current Detection Signal.....	- 92 -
5.2.5 Software Version Display.....	- 94 -
5.2.6 Position Teaching Function.....	- 94 -
5.2.7 Static Inertia Detection.....	- 94 -
5.2.8 Parameters Copy.....	- 95 -
Chapter 6.....	- 96 -
MODBUS Communication.....	- 96 -
6.1RS-485 Communication Wiring.....	- 96 -
6.2MODBUS Communication Related Parameters.....	- 96 -
6.3 MODBUS Communication Protocol.....	- 98 -
6.3.1 Code Meaning.....	- 98 -
6.3.2 Communication Error Disposal.....	- 104 -
6.3.3 Data Communication Address of Servo State.....	- 105 -
Chapter 7.....	- 107 -
Specifications and Characters.....	- 107 -
7.1 Servo drive Specifications and Models.....	- 107 -
7.2 Servo drive Dimensional Drawings.....	- 109 -
Appendix A.....	- 110 -
Parameter.....	- 110 -
A.1 Parameter List.....	- 110 -
A.2 Description of Parameter Type.....	- 116 -
A.3 Parameters in detail.....	- 117 -
Appendix B.....	- 133 -
Alarm Display.....	- 133 -

Chapter 1

Checking Products and Parts Names

1.1 Checking Products on Delivery

Check Items	Comments
Are the delivered products theones that were ordered?	Check the model numbers marked on the nameplate on theservomotor and servo drive.
Is there any damage?	Check the overall appearance, and check for damage or scratches that may have occurred during shipping.
Does the servomotor shaft rotatesmoothly?	If the servomotor shaft can be easily rotated by hand, then the motor is working normally. However, if a brake is installed on the servomotor, then it cannot be turned by hand.

If any of the above items are faulty or incorrect, contact your ESTUN representative or the dealer from whom you purchased the products.

1.1.1 Servomotor

■ Servomotor Model Designation

EMJ- 08 A P B 1 1 -WR

ESTUN Servomotor							
EMJ Model	【1+2】	【3】	【4】	【5】	【6】	【7】	【8+9】

【1+2】

Rated Output

Code	Spec.
02	0.2kW
04	0.4kW
08	0.75kW
10	1.0 kW

【4】 Encoder

Code	Spec.
P	Incremental Wire-saving Type: 2500P/R

【7】 Option

Code	Spec.
1	None
2	With oil seal
3	With brake (DC24V)
4	With oil seal and brake(DC24V)

【5】 Designing Sequence

Code	Spec.
A	Designing sequence A
B	Designing sequence B

【8+9】 Connector

Code	Spec.
	Standard connector
WR	Water proof connector (Incremental Wire-saving Type)

【3】 Voltage

Code	Spec.
A	200VAC

【6】 Shaft End

Code	Spec.
1	Straightwithoutkey (Standard)
2	Straightwithkey andtap

EMG- 10 A P A 1 1

ESTUN Servomotor	【1+2】	【3】	【4】	【5】	【6】	【7】
EMG Model						

【1+2】

Rated Output

Code	Spec.
10	1.0kW

【4】 Encoder

Code	Spec.
P	Incremental Wire-saving Type: 2500P/R

【7】 Option

Code	Spec.
1	None
2	With oil seal
3	With brake (DC24V)
4	With oil seal and brake(DC24V)

【3】 Voltage

Code	Spec.
A	200VAC

【5】 Designing Sequence

Code	Spec.
A	Designing sequence A

【6】 Shaft End

Code	Spec.
1	Straight without key (Standard)
2	Straight with key and tap

EML- 10 A P A 1 1

ESTUN Servomotor	【1+2】	【3】	【4】	【5】	【6】	【7】
EML Model						

【1+2】

Rated Output

Code	Spec.
10	1.0kW

【4】 Encoder

Code	Spec.
P	Incremental Wire-saving Type: 2500P/R

【7】 Option

Code	Spec.
1	None
2	With oil seal
3	With brake (DC24V)
4	With oil seal and brake(DC24V)

【3】 Voltage

Code	Spec.
A	200VAC

【5】 Designing Sequence

Code	Spec.
A	Designing sequence A

【6】 Shaft End

Code	Spec.
1	Straight without key (Standard)
2	Straight with key and tap

■ Appearance and Nameplate

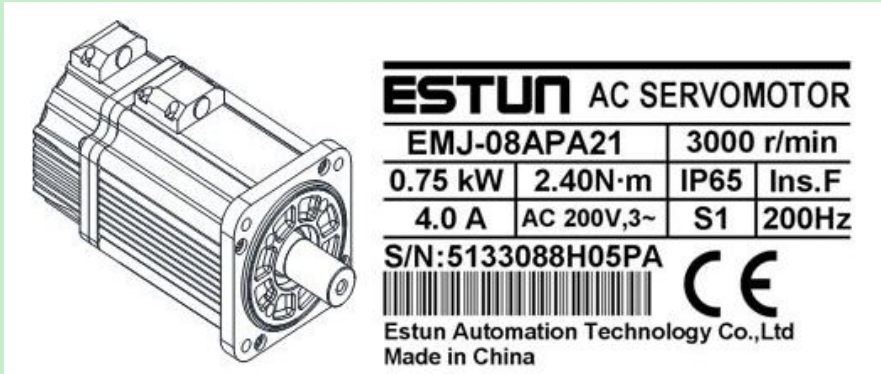

1.1.2 Servo drive

■ Servo Drive Appearance and Nameplate

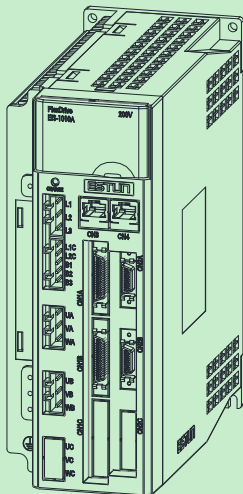
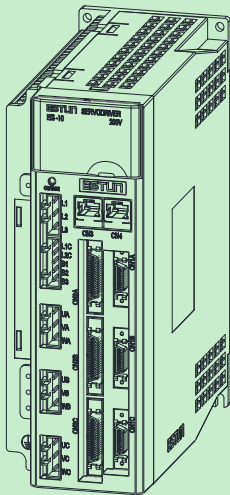

■ Servo drive Model Designation

ETS -10 10 A P C- CAN

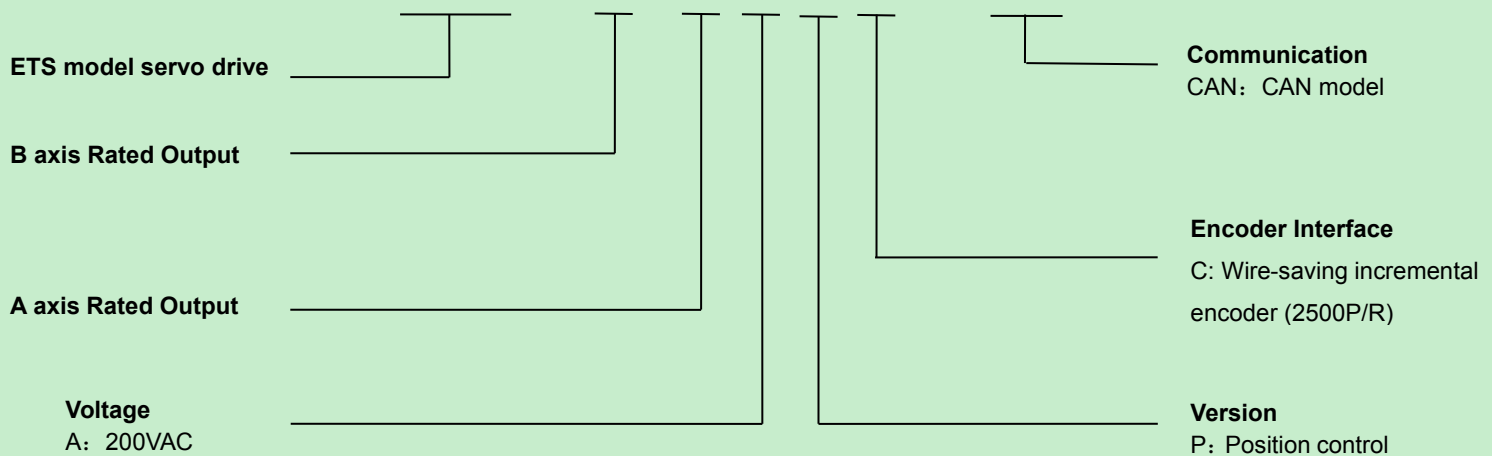

Notes : Each axis of ETS servo drive equips 200W、400W、750W、1.0kW servo motor, and assures three times overload capacity.

ETS-101010AP C- CAN

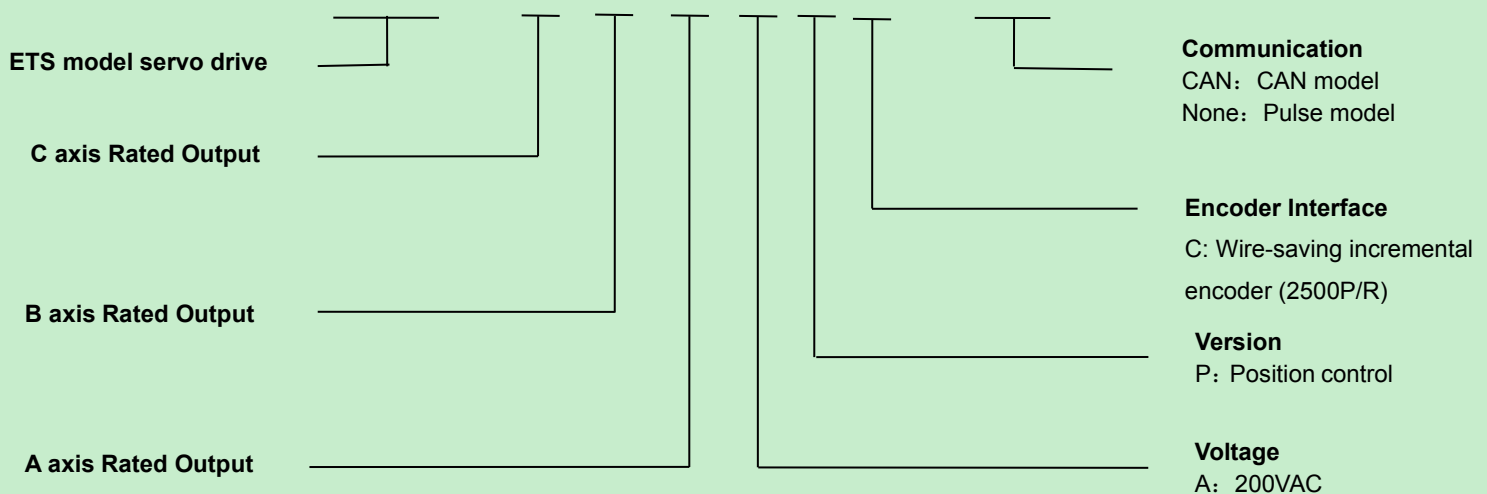

Notes : Each axis of ETS servo drive equips 200W、400W、750W、1.0kW servo motor, and assures three times overload capacity.

1.2 Part Names

1.2.1 Servomotor

Servomotor without gear and brake.

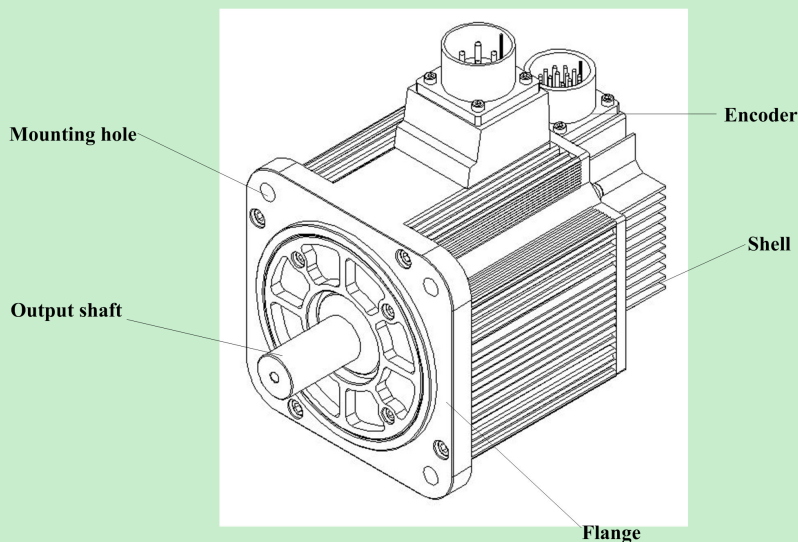

1.2.2 Servo drive

■ ETS two-axis servo drive

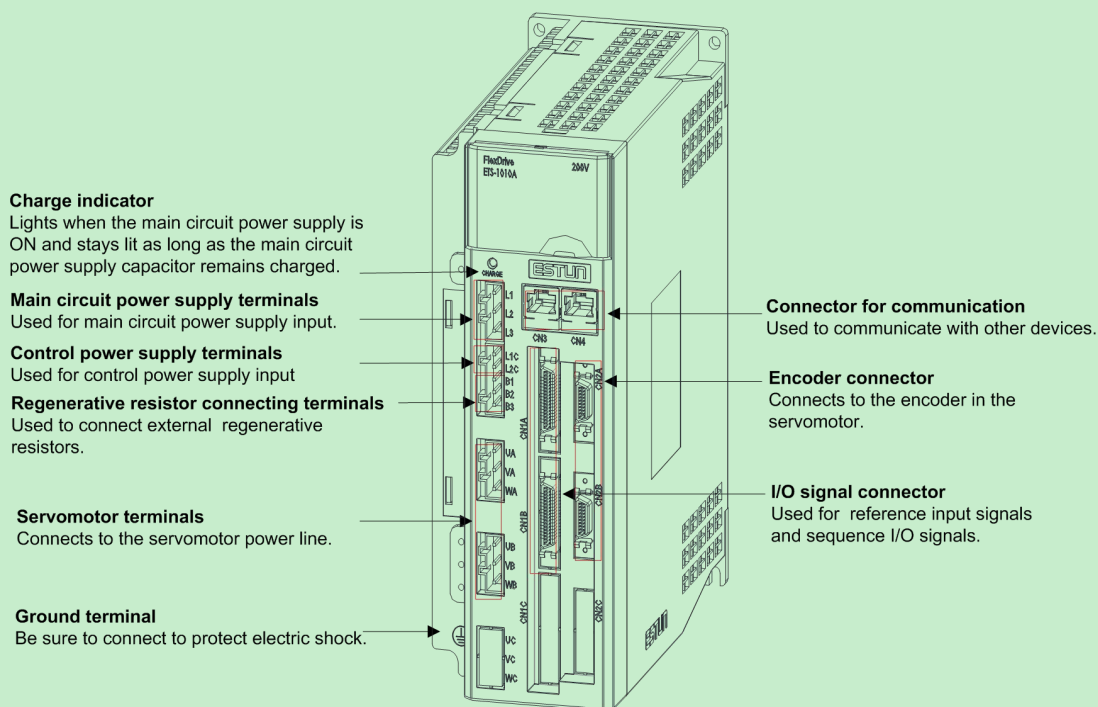

■ ETS three-axis servo drive

Charge indicator

Lights when the main circuit power supply is ON and stays lit as long as the main circuit power supply capacitor remains charged.

Main circuit power supply terminals

Used for main circuit power supply input.

Control power supply terminals

Used for control power supply input

Regenerative resistor connecting terminals

Used to connect external regenerative resistors.

Servomotor terminals

Connects to the servomotor power line.

Ground terminal

Be sure to connect to protect electric shock.

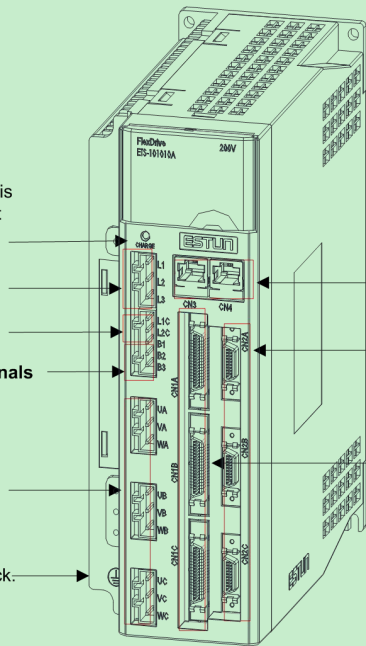

Connector for communication

Used to communicate with other devices.

Encoder connector

Connects to the encoder in the servomotor.

I/O signal connector

Used for reference input signals and sequence I/O signals.

Chapter 2

Installation

2.1 Servomotor

Servomotor can be installed either horizontally or vertically. However, if the servomotor is installed incorrectly, the service life of the servomotor will be shortened or unexpected problems may occur.

Please observe the installation instructions described below to install the servomotor correctly.

Before installation:

Anticorrosive paint is coated on the edge of the servomotor shaft. Clean off the anticorrosive paint thoroughly using a cloth moistened with thinner.

Avoid getting thinner on other parts of the servomotor when cleaning the shaft.

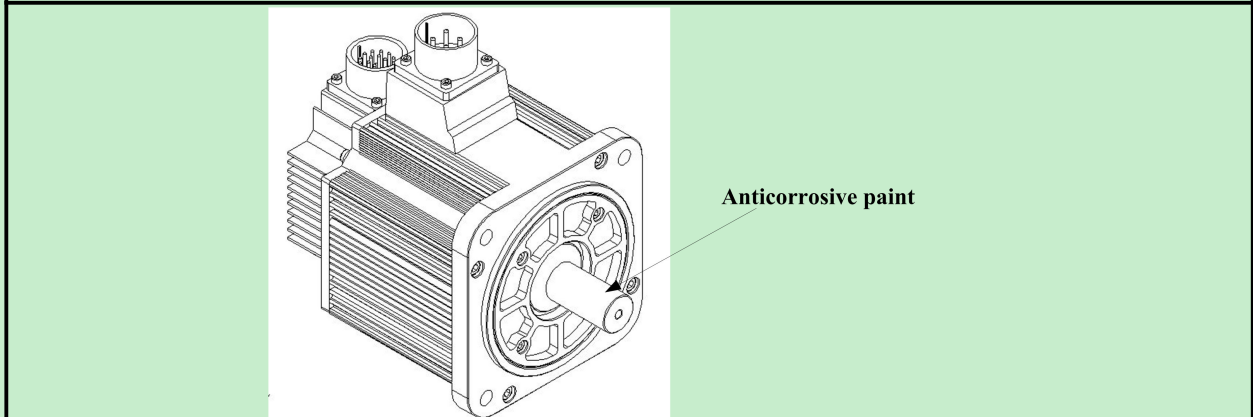

2.1.1 Storage

When the servomotor is not being used, store it in an area with a temperature between -20°C and 60°C with the power cable disconnected.

2.1.2 Installation Sites

The servomotor is designed for indoor use. Install the servomotor in an environment which meets the following conditions.

- Free from corrosive and explosive gases.
- Well-ventilated and free from dust and moisture.
- Ambient temperature from 0 to 40°C .
- Relative humidity from 26% to 80% (non-condensing).
- Facilitates inspection and cleaning.

2.1.3 Installation Alignment

Align the shaft of the servomotor with that of the machinery shaft to be controlled. Then connect the two shafts with an elastic coupling.

Install the servomotor so that alignment accuracy falls within the range shown below.

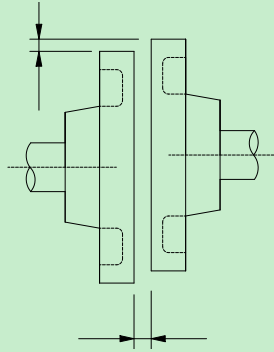

Measure this distance at four different positions in the circumference. The difference between the maximum and minimum measurements must be 0.03mm or less. (Turn together with couplings.)

Note:

- If the alignment accuracy is incorrect, vibration will occur, resulting in damage to the bearings.
 - Mechanical shock to the shaft end is forbidden, otherwise it may result in damage to the encoder of the servomotor.
-

2.1.4 Installation Orientation

Servomotor can be installed either horizontally or vertically.

2.1.5 Handling Oil and Water

If the servomotor is used in a location that is subject to water or oil drops, make sure of the servomotor protective specification. If the servomotor is required to meet the protective specification to the through shaft section by default, use a servomotor with an oil seal.

Through shaft section:

It refers to the gap where the shaft protrudes from the end of the servomotor.

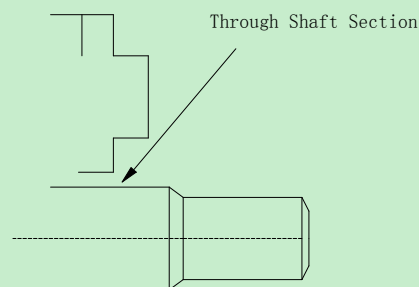

2.1.6 Cable Tension

When connecting the cables, the bending radius should not be too small, do not bend or apply tension to cables. Since the conductor of a signal cable is very thin (0.2 mm or 0.3 mm), handle it with adequate care.

2.1.7 Install to the Client

When the servo motor is mounted to the client, please firmly secure the servo motor by the screws with backing ring as shown in the figure.

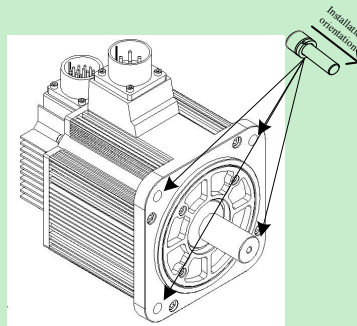

2.2 Servo Drive

ETS series servo drive is a base-mounted type. Incorrect installation will cause problems. Always observe the installation instructions described below.

2.2.1 Storage

When the servomotor is not being used, store it in an area with a temperature between -20°C and 85°C with the power cable disconnected.

2.2.2 Installation Sites

Notes on installation are shown below.

Situation	Notes on installation
When installed in a control panel	Design the control panel size, unit layout, and cooling method so that the temperature around the periphery of the servo drive does not exceed 55°C .
When installed near a heating unit	Suppress radiation heat from the heating unit and a temperature rise caused by convection so that the temperature around the periphery of the servo drive does not exceed 55°C .
When installed near a source of vibration	Install a vibration isolator underneath the servo drive to prevent it from receiving vibration.
When installed in a location subject to corrosive gases	Take appropriate action to prevent corrosive gases. Corrosive gases do not immediately affect the servo drive, but will eventually cause contactor-related devices to malfunction.
Others	Avoid installation in a hot and humid site or where excessive dust or iron powder is present in the air.

2.2.3 Installation Orientation

Install the servo drive perpendicular to the wall as shown in the figure. The servo drive must be oriented this way because it is designed to be cooled by natural convection or a cooling fan if required. Firmly secure the servo drive through two mounting holes.

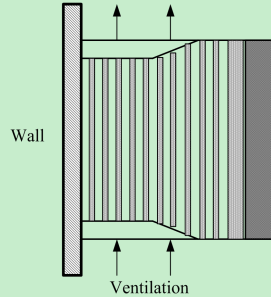

2.2.4 Installation Method

When installing multiple servo drives side by side in a control panel, observe the following installation method.

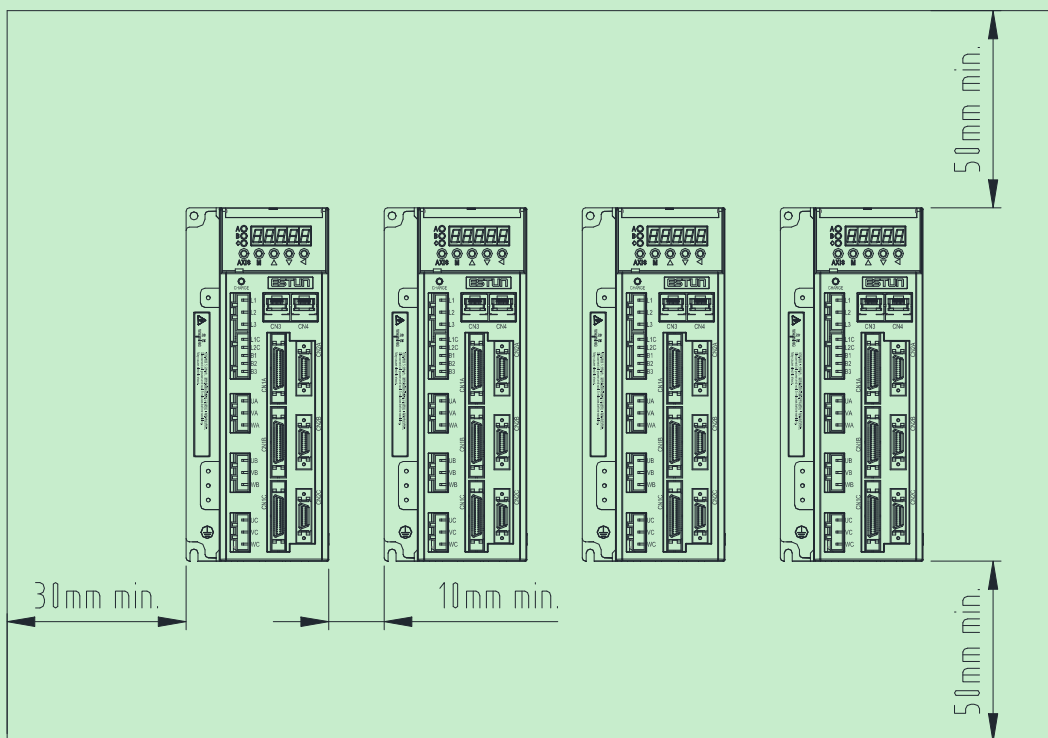

■ Installation Orientation

Install servo drive perpendicular to the wall so that the front panel (containing connectors) faces outward.

■ Cooling

Provide sufficient space around each servo drive to allow cooling by natural convection or fans.

■ Installing side by side

When installing servo drives side by side, provide at least 30mm space from the cabinet, at least 10mm space

between each individual servo drive and at least 50mm space above and below each one as well as shown in the figure above. Ensure the temperature inside the control panel is evenly distributed, and prevent the temperature around each servo drive from increasing excessively. Install cooling fans above the servo drives if necessary.

■ **Working conditions**

1. Temperature: 0~ 55°C
2. Humidity: 90%RH or less (no condensation)
3. Vibration: 4.9m/s² or less
4. Ambient temperature to ensure long-term reliability: 45°C or less

Chapter 3

Wiring

3.1 Main Circuit Wiring

Please observe the following instructions while wiring the main circuit.

 CAUTION

- Do not bundle or run power and signal lines together in the same duct. Keep power and signal lines separated by at least 300 mm.
- Use twisted-pair shielded wires or multi-core twisted-pair shielded wires for signal and encoder feedback lines.
- The maximum length is 3 m for reference input lines and 20 m for encoder feedback lines.
- Do not touch the power terminals for 5 minutes after turning power OFF because high voltage may still remain in the servo drive.

3.1.1 Typical Main Circuit Wiring Examples

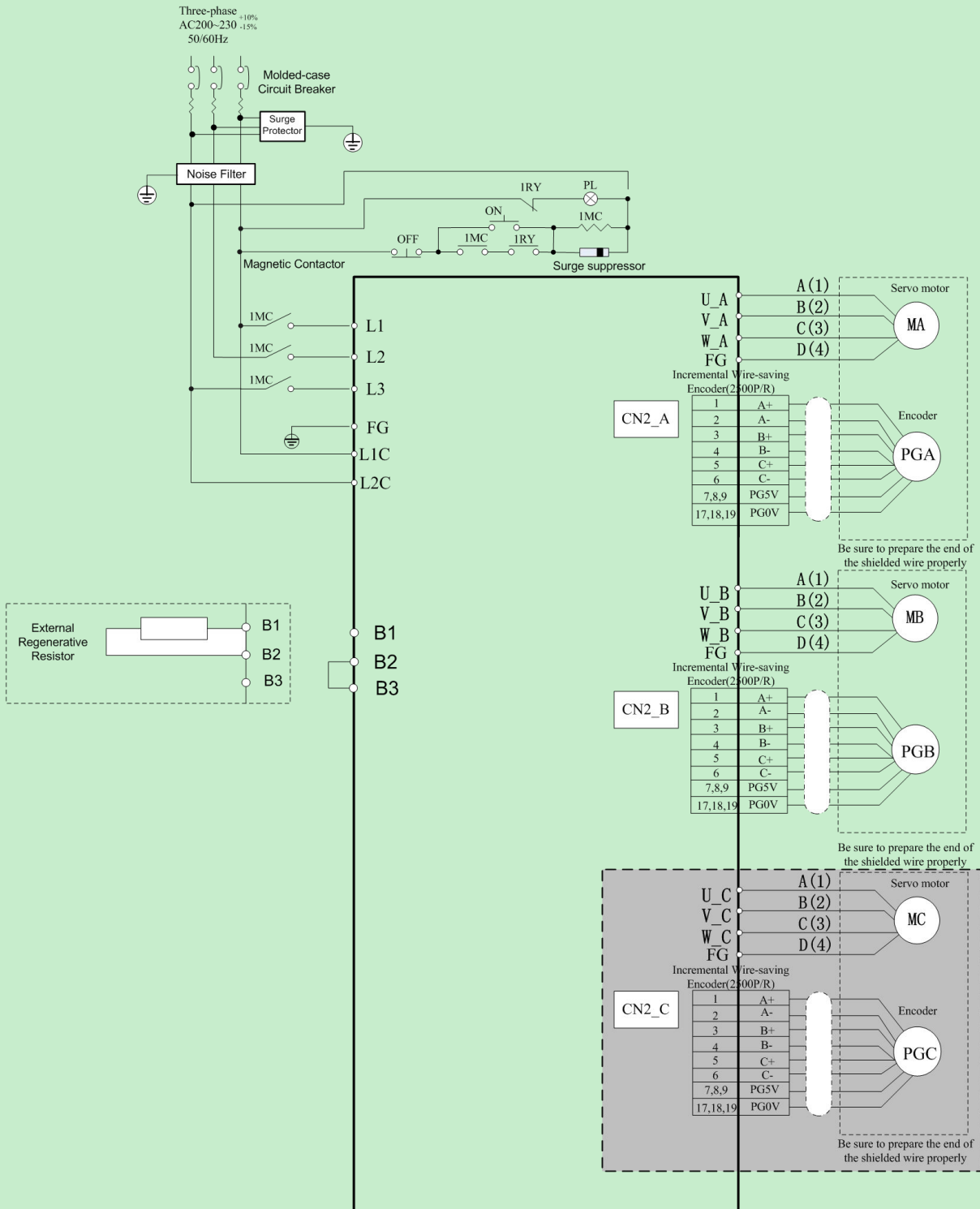

Note :The wiring of ETS two-axis servo drive does not include the gray part of graph.

3.1.2 Names and Functions of Main Circuit Terminals

Terminal Symbol	Name	Functions
L1, L2, L3	Main circuit power supply input terminal	Three-phase 200~230VAC +10%~-15% (50/60Hz)
U_A, V_A, W_A	Axis A servomotor connection terminals	Connect to the axis A servomotor.
U_B, V_B, W_B	Axis B servomotor connection terminals	Connect to the axis B servomotor.
U_C, V_C, W_C	Axis C servomotor connection terminals	Connect to the axis C servomotor.
L1C, L2C	Control circuit power supply input terminal	Single-phase 200~230VAC +10%~-15% (50/60Hz)
	Ground terminals	Connects to the power supply ground terminals and servomotor ground terminal.
B1, B2, B3	External regenerative resistor connection terminal	If using an internal regenerative resistor, please short B2 and B3. Remove the wire between B2 and B3 and connect an external regenerative resistor(provided by customer) between B1 and B2, if the capacity of the internal regenerative resistor is insufficient.

3.2 I/O Signals

3.2.1 Examples of I/O Signal Connections

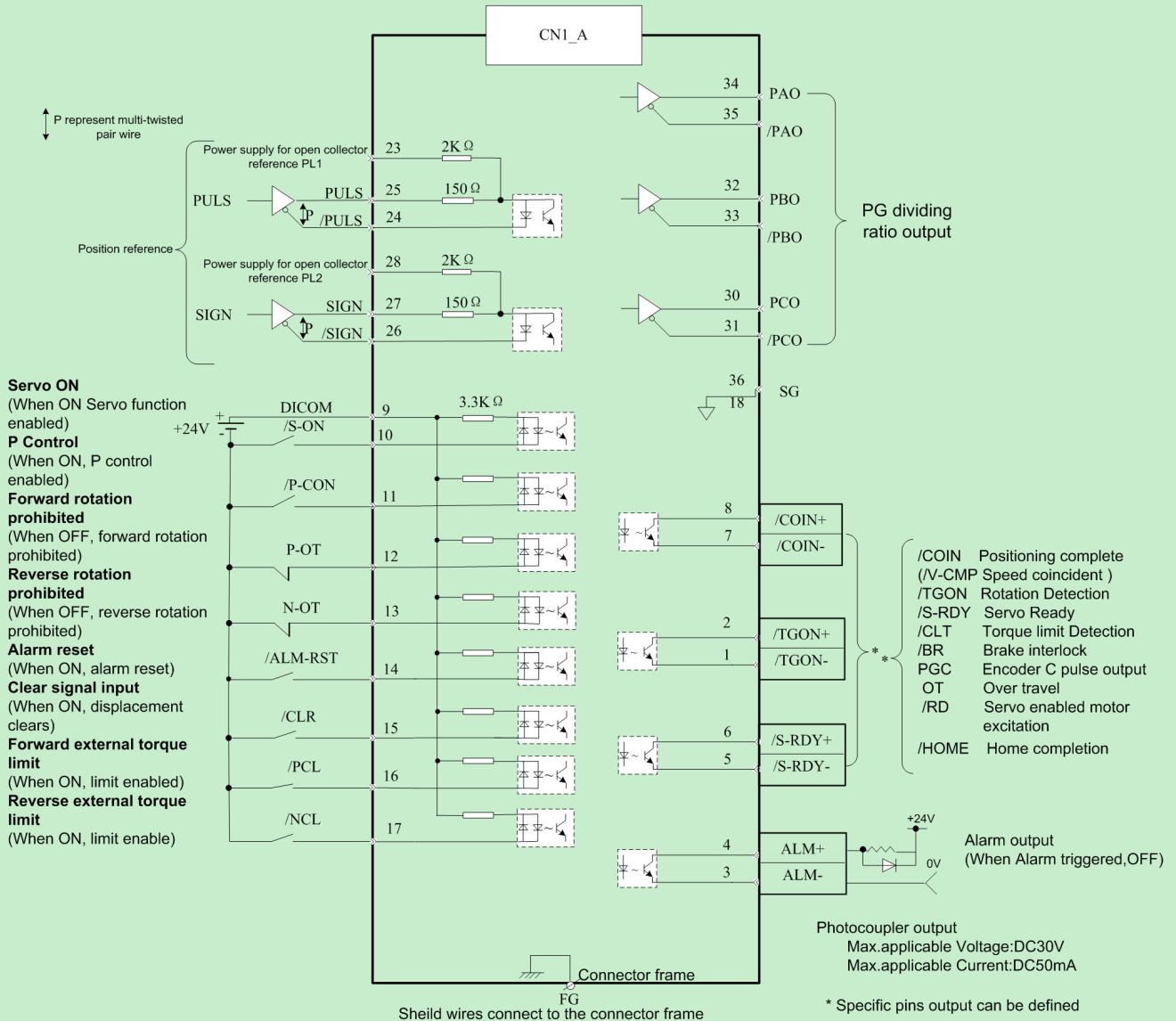

Note: The wirings of CN1_A、CN1_B、CN1_C are the same.

3.2.2 I/O Signal Connector (CN1_A/CN1_B/CN1_C) Terminal Layout

Terminal No.	Name	Function
(*)	0: /COIN(/VCMP)	0: Positioning completion (speed agree detection)
1	1: /TGON	1: Running signal output
2	2: /S-RDY	2: Servo ready
(*)	3: /CLT	3: Torque limit output
5	4: /BK	4: Brake interlock output
6	5: PGC	5: C pulse output
(*)	6: OT	6: Over travel signal output
7	7: /RD	7: Servo enabled motor excitation output
8	8: /HOME	8: Home completion output
3	ALM-	Servo alarm: Turns off when an error is detected.
4	ALM+	
9	DICOM	Control power supply input for I/O signals: Provide the +24V DC power supply
(*)	0: /S-ON	0: Servo ON
10	1: /P-CON	1: P/PI control input
11	2: P-OT	2: Forward run prohibited
12	3: N-OT	3: Reverse run prohibited
13	4: /ALM-RST	4: Alarm reset
(*)	5: /CLR	5: Position error pulseclear input
14	6: /PCL	6: Forward torque limitinput
15	7: /NCL	7: Reverse torque limitinput
16	8: /G-SEL	8: External switch gain switching
17	9: /JDPOS-JOG+	9: Position control (contact reference)-forward direction JOG
	A: /JDPOS-JOG-	A: Position control (contact reference)-reverse direction JOG
	B: /JDPOS-HALT	B: Position control (contact reference) -stop JOG
	C: Reserved	C: Reserved
	D: SHOME	D: Hometrigger
	E: ORG(ZPS)	E: Zero position
23	PPIP	Power supply input for open collector reference
28	PPIS	
24	PULS-	Pulse signal
25	PULS+	
26	SIGN-	Direction signal
27	SIGN+	
30	PCO+	Phase-C signal
31	PCO-	
32	PBO+	Phase-B signal
33	PBO-	
34	PAO+	Phase-A signal

Terminal No.	Name	Function
35	PAO-	
18, 36	DGND	DGND
Shell	FG	FG

Notes :

- 1.The list of CN1_A、CN1_B、CN1_C about I/O Signal Names and Functions are the same.
- 2.(*)The signals of CN1_A/B/C-1、2, CN1_A/B/C-5、6, CN1_A/B/C-7、8 can be modified by Pn511 ;
(*)The signals of CN1_A/B/C-10、11、12、13 can be modified by Pn509 ;
(*)The signals of CN1_A/B/C-14、15、16、17 can be modified by Pn510 ;
Please refer to **A.3 Parameters in details** for detailed information.

Notes :

1. Spare terminals can not be used for relay purpose.
 2. Connect shielded cable wires of I/O signals to connector shell(frame grounding).
-

3.2.3 I/O Signal Names and Functions

Name	Terminal No.	Function	
DICOM	9	Control power supply input for I/O signals: Provide the +24V DC power supply	
/S-ON	10	Servo ON: Turns the servomotor on.	The function of I/O are default, it can be changed by setting parameters.
/P-CON	11	It has deferent means depends on deferent control mode.	
P-OT	12	Forward run prohibited	
N-OT	13	Reverse run prohibited	
/ALM-RST	14	Alarm reset: Releases the servo alarm state.	
/CLR	15	Positional error pulse clear input: Clear the positional error pulse during position control.	
/PCL	16	Forward externaltorque limit	
/NCL	17	Reverse externaltorque limit	
PPIP	23	Power supply input for open collector reference(pulse)	
PPIS	28	Power supply input for open collector reference(direction)	
PULS-	24	Reference pulse input Reference sign input	Pulse reference input mode: Sign + pulse train CCW + CW pulse Two-phase pulse
PULS+	25		
SIGN-	26		
SIGN+	27		
/COIN- (/V-CMP-)	7	Positioning completion(Speed coincidence): Turns ON when the number of positional error pulses reaches the value set.	The function of I/O are default, it can be changed by setting parameters.
/COIN+ (/V-CMP+)	8		
/TGON-	1	Motor rotation detection: when the servomotor is rotating at a speed higher than the motor speed setting.	
/TGON+	2		
/S-RDY-	5	Servo ready: ON if there is no servo alarm when the control/main circuit power supply is turned ON.	
/S-RDY+	6		
ALM-	3	Servo alarm:	
ALM+	4	Turns off when an error is detected.	
PAO+	34	Phase-A signal	Converted two-phase pulse(phases A and B) encoder output.
PAO-	35		
PBO+	32	Phase-B signal	
PBO-	33		
PCO+	30	Phase-C signal	Zero-point pulse(Phase-C) signal
PCO-	31		
GND	18,36	GND	
FG	Shell	Connect frame to ground if the shield wire of the I/O signal cable is connected to the	

	connector shell.
--	------------------

3.2.4 Interface Circuit

This section shows examples of servo drive I/O signal connection to the host controller.

■ Interface for input circuit

The input circuit interface connects through a relay or open-collector transistor circuit. Select a low-current relay otherwise a faulty contact will result.

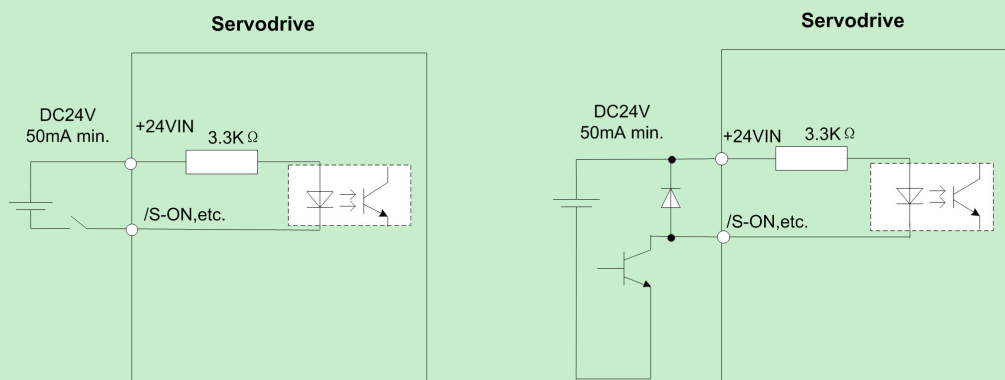

■ Interface for encoder and servo drive output circuits

The amount of two-phase (phase A and phase B) pulse output signals (PAO,/PAO,PBO,/PBO) and zero-point pulse signals(PCO,/PCO) are output via line-driver output circuits. Normally, the servo drive uses this output circuit in speed control to comprise the position control system at the host controller. Connect the line-driver output circuit through a line receiver circuit at the host controller.

■ Interface for sequence output circuit

Photo-coupling isolation output is required for output signals of servo alarm, positioning complete and brake interlock.

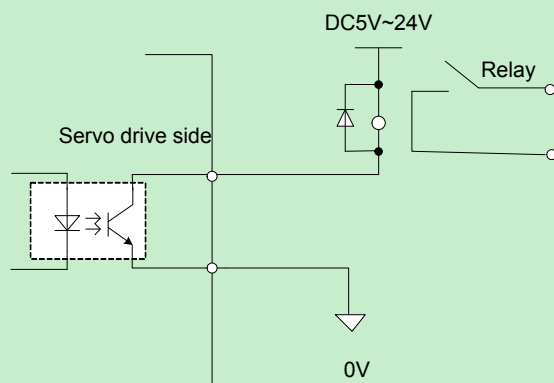

Note:

Maximum voltage should be no more than 30VDC, and maximum current should be no more than 50mA.

3.3 Wiring Encoders

3.3.1 Connecting an Encoder(CN2_A/ CN2_B/ CN2_C)

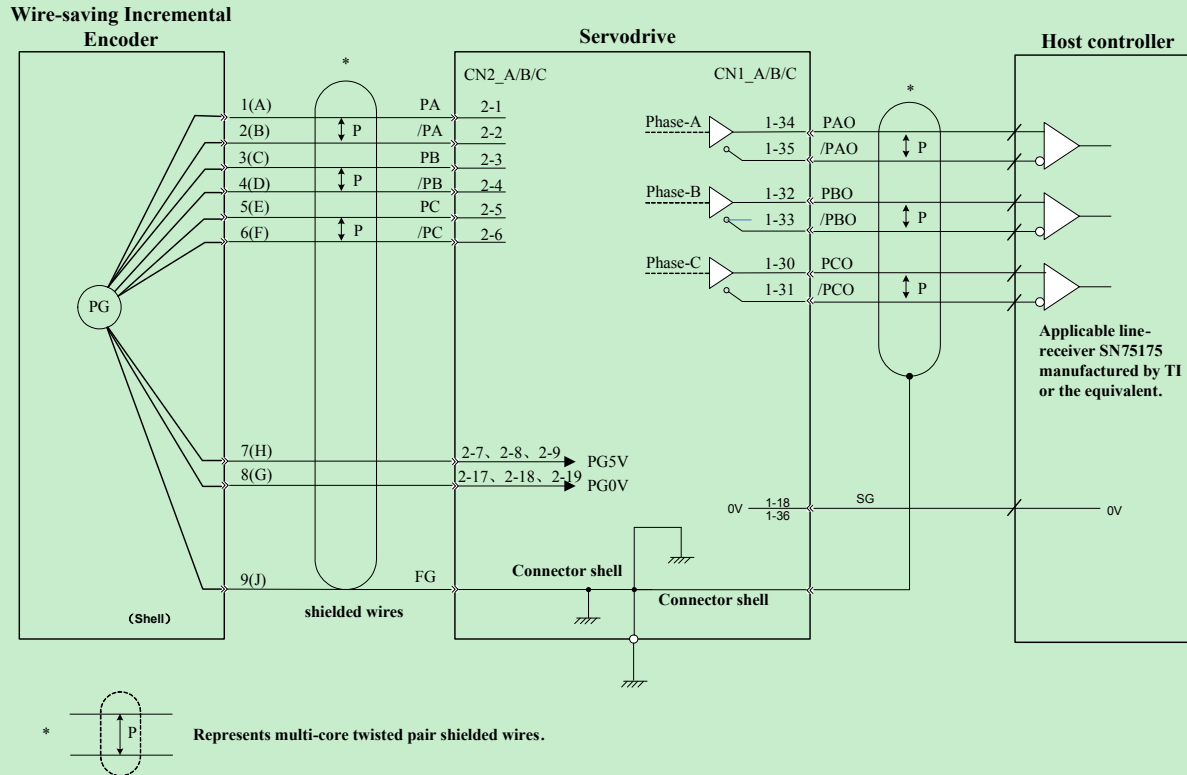

3.3.2 Encoder Connector(CN2_A/ CN2_B/ CN2_C) Terminal Layout

Name	Terminal No.	Function
PA+	1	PG input phase A+
PA-	2	PG input phase A-
PB+	3	PG input phase B+
PB-	4	PG input phase B-
PC+	5	PG input phase C+
PC-	6	PG input phase C-
PG5V	7、8、9	PG power supply +5V
GND	17、18、19	PG power supply 0V
FG	Shell	Connect frame to ground if the shield wire of the PG signal cable is connected to the connector shell.

3.4 Communication Connection (CN3/CN4)

Terminal No.	Name	Function
1	—	Reserved
2	—	
3	485+	RS-485 communication terminal
4	ISO_GND	Isolated ground
5	ISO_GND	
6	485-	RS-485 communication terminal
7	CANH	CAN communication terminal
8	CANL	CAN communication terminal

Note: Do not short terminal 1 and 2.

3.5 Standard Wiring Example

Motor connector specification

Plug: 172167-1 (AMP)

Pin: 170360-1 (AMP)

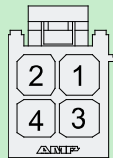

Pin No.	Signal
1	U
2	V
3	W
4	FG

Encoder connector specification

Plug: 172169-1 (AMP)

Pin: 170359-3 (AMP)

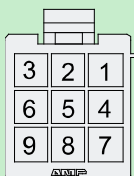

Pin No.	Signal
1	A+
2	B+
3	C+
4	A-
5	B-
6	C-
7	PG5V
8	PG0V
9	FG

3.6 Standard Wiring Example

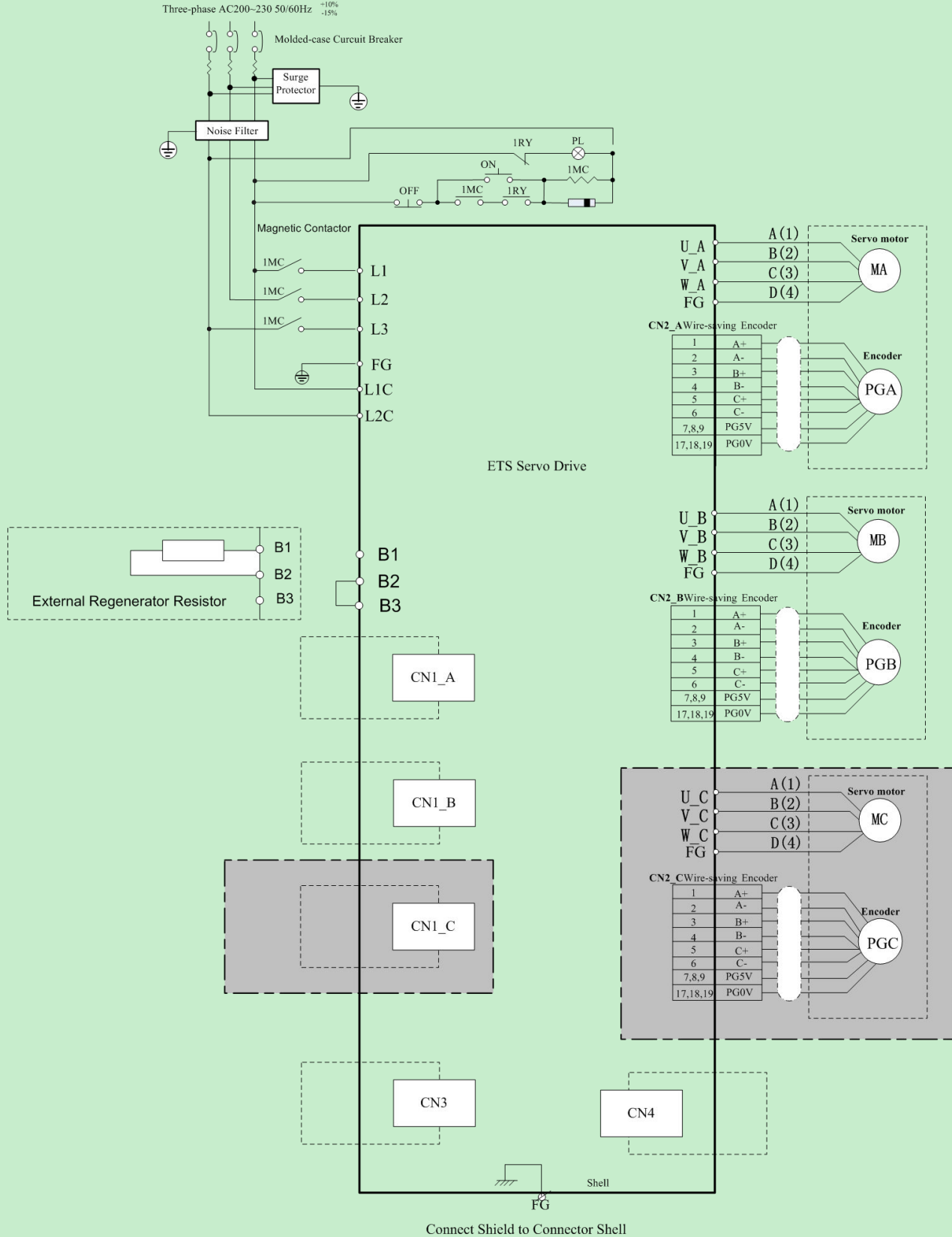

CN1_A、CN1_B、CN1_C:

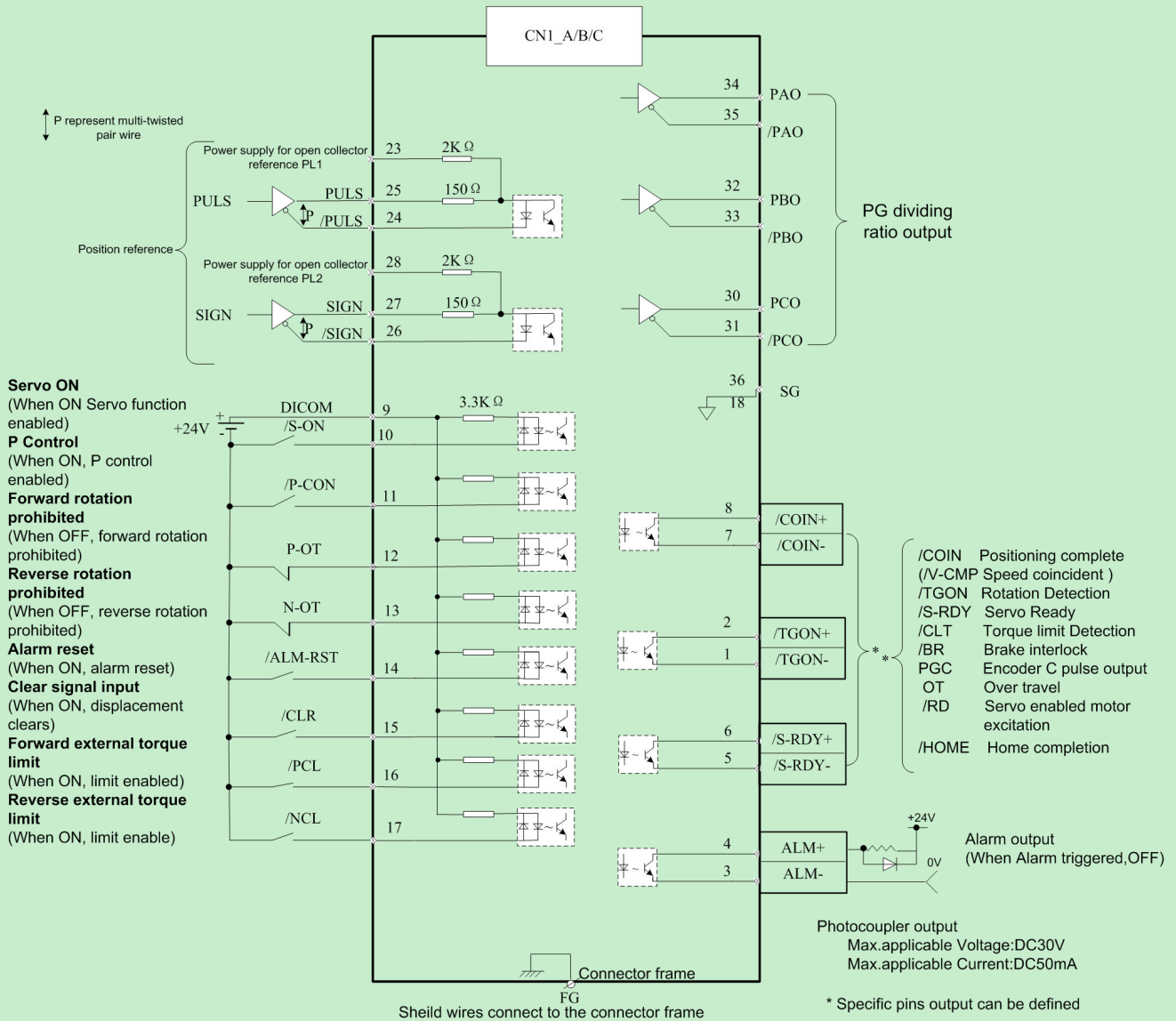

CN3\CN4:

1	-
2	-
3	485+
4	ISO_GND
5	ISO_GND
6	485-
7	CANH
8	CANL

3.7 Wiring for Noise Control

3.7.1 Noise Control

The servodrive uses high-speed switching elements in the main circuit. It may receive "switching noise" from these high-speed switching elements.

To prevent malfunction due to noise, take the following actions:

- Position the input reference device and noise filter as close to the servo drive as possible.
- Always install a surge absorber in the relay, solenoid and electromagnetic contactor coils.
- The distance between a power line (servomotor main circuit cable) and a signal line must be at least 30 cm. Do not put the power and signal lines in the same duct or bundle them together.
- Do not share the power supply with an electric welder or electrical discharge machine. When the servo drive is placed near a high-frequency generator, install a noise filter on the input side of the power supply line. As for the wiring of noise filter, refer to **(1) Noise Filter** shown below.
- For proper grounding technique, refer to **(2) Correct Grounding**.

(1) Noise Filter

Please install a noise filter in the appropriate place to protect the servo drive from external noise interference.

Notice:

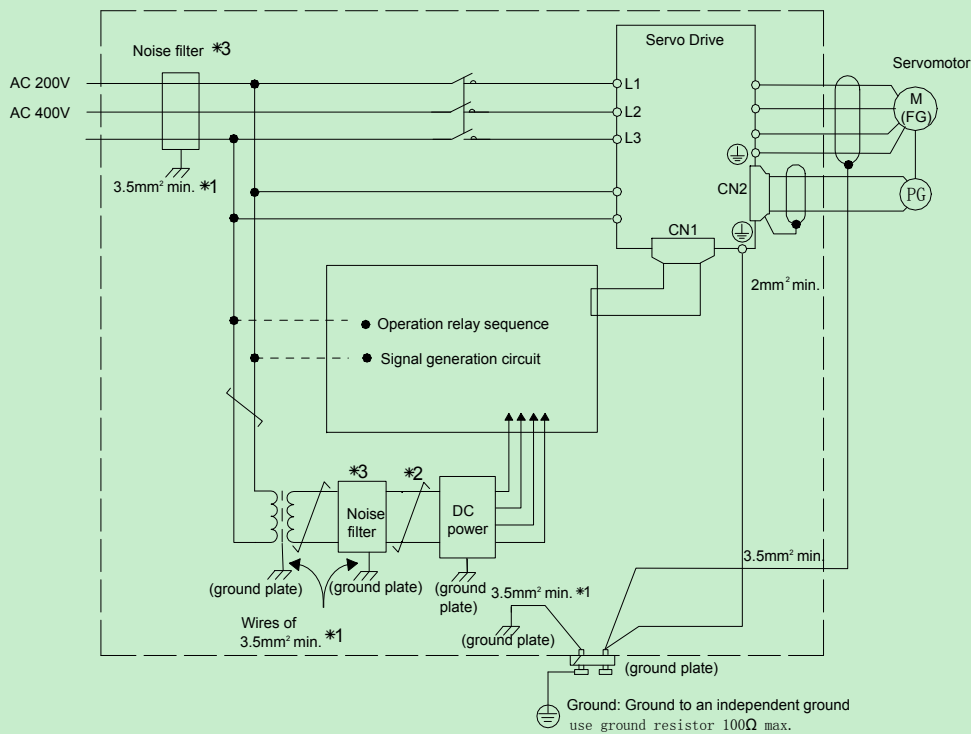

- For ground wires connected to the ground plate, use a thick wire with a thickness of at least 3.5 mm² (preferably, plain stitch cooper wire)

-  should be twisted-pair wires.

•When using a noise filter, follow the precautions in **3.6.2 Precautions on Connecting Noise Filter**.

(2) Correct Grounding

Take the following grounding measures to prevent the servo drive from malfunctioning due to noise.

■ Grounding the Motor Frame

If the servomotor is grounded via the machine, a switching noise current will flow from the servo drive main circuit through the servomotor stray capacitance.

Always connect servomotor frame terminal FG to the servodrive ground terminal. Also be sure to ground the ground terminal .

■ Noise on the I/O Signal Line

If the I/O signal line receives noise, ground the 0 V line (SG) of the reference input line. If the main circuit wiring for the motor is accommodated in a metal conduit, ground the conduit and its junction box. For all grounding, ground at one point only.

(3) Precautions on installing on the control panel

- When the servo drive is installed on the control panel, a piece of metal plate should be fixed. It is used for fixing the servo drive and other peripheral devices. The noise filter should be installed on the metal plate, and closed to the hole drill through power lines on control panel. Use screws to fix the noise filter to the metal plate. The grounding terminals of noise filter connects to the grounding terminals of control panel.
- Servo drive should be fixed on a piece of metal plate. Make sure the heat sink towards ground. The grounding terminals of servo drive connect to the grounding terminals of control panel.

3.7.2 Precautions on Connecting Noise Filter

(1) Noise Filter Brake Power Supply

Use the noise filter Manufactured by SCHAFFNER at the brake power input for servomotors with holding brakes.

Relationship between servo drive power and noise filter current:

Servo Motor Power	Noise Filter Current for single motor
200W	2A
400W	3A
750W	5A
1.0kW	6A

Note:

1. A single-phase servomotor should apply a two-phase filter. A three-phase servo drive should apply a three-phase filter.
2. Choose the right filter according the specifications of operating voltage, current, and manufacturer.

(2) Precautions on Using Noise Filters

Do not put the input and output lines in the same duct or bundle them together.

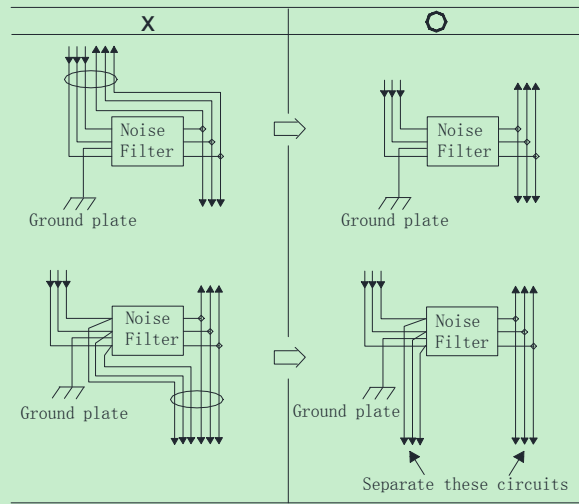

Separate the noise filter ground wire from the output lines.

Do not accommodate the noise filter ground wire, output lines and other signal lines in the same duct or bundle them together.

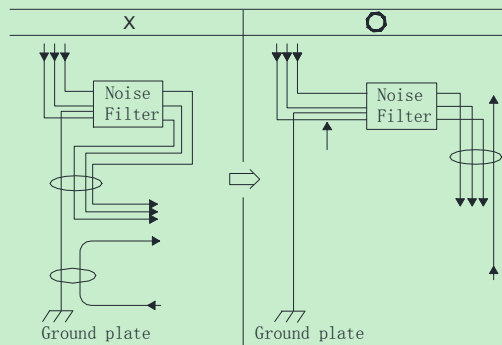

Connect the noise filter ground wire directly to the ground plate. Do not connect the noise filter ground wire to other ground wires.

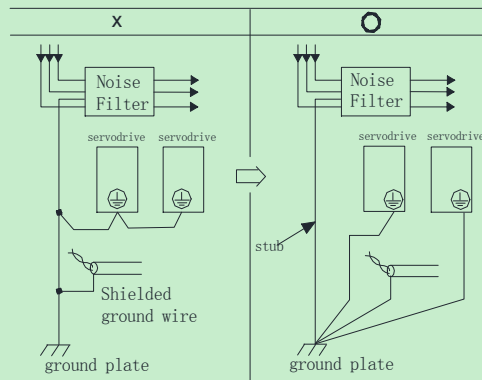

If a noise filter is located inside a control panel, connect the noise filter ground wire and the ground wires from other devices inside the control panel to the ground plate for the control panel first, then ground these wires.

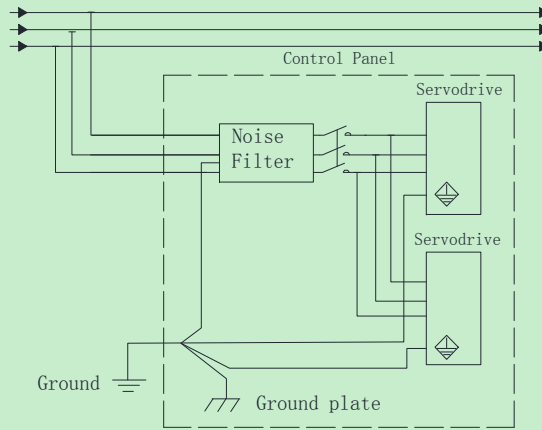

Chapter 4

Operation

4.1 Trial Operation

Make sure that all wiring has been completed prior to trial operation.

Perform the following three types of trial operation in order. Instructions are given for speed control mode (standard setting) and position control mode. Unless otherwise specified, the standard parameters for speed control mode (factory settings) are used.

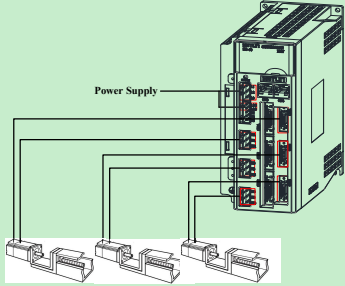
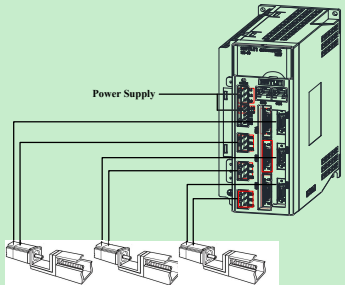
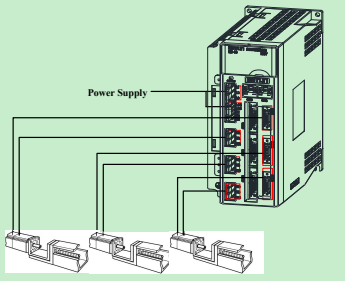
(1) Trial Operation for Servomotor Without Load (Refer to 4.1.1)	
	<p>■ Purpose</p> <p>The servomotor is operated without connecting the shaft to the machine in order to confirm the following wiring is correct.</p> <ul style="list-style-type: none"> • Power supply circuit wiring • Servomotor wiring • Encoder wiring • Rotation direction and speed of servomotor. <p style="text-align: right;">(Please refer to step 1-4)</p>
(2) Trial operation for servomotor with host reference (Refer to 4.1.2)	
	<p>■ Purpose</p> <p>The servomotor is operated without connecting the shaft to the machine in order to confirm the following wiring is correct.</p> <ul style="list-style-type: none"> • I/O signal wiring with host controller • Rotation direction, speed and number of rotations of servomotor. • Check the operation of the brake, overtravel and other protective functions. <p style="text-align: right;">(Please refer to step 5-8)</p>
(3) Trial operation for servomotor and machine combined. (Refer to 4.1.3)	
	<p>■ Purpose</p> <p>Perform the trial operation with the servomotor connected to the machine. The servo drive is adjusted to match the machine characteristics.</p> <ul style="list-style-type: none"> • Servomotor speed and machine travel distance. • Set the necessary parameters. <p style="text-align: right;">(Please refer to step 9-11)</p>



Step	Item	Description	Reference
1	Installation	Install the servomotor and servo drive according to the installation conditions. (Do not connect the servomotor to the machine because the servomotor will be operated first under the no-load condition for checking.)	-
↓			
2	Wiring	Connect the power supply circuit (L1, L2 and L3), servomotor wiring (U, V, W), I/O signal wiring (CN1_A/B/C), and encoder wiring (CN2_A/B/C). But during (1) Trial Operation for Servomotor Without Load, disconnect the CN1_A/B/C connector.	-
↓			
3	Turn the power ON	Turn the power ON. Using the panel operator to make sure that the servo drive is running normally. If using a servomotor equipped with an absolute encoder, please perform the setup for the absolute encoder.	-
↓			
4	Execute JOG operation	Execute JOG operation with the servomotor alone under the no-load condition.	JOG Operation
↓			
5	Connect input signals	Connect the input signals (CN1_A/B/C) necessary for trial operation to the servo drive.	-
↓			
6	Check input signals	Use the internal monitor function to check the input signals. Turn the power ON, and check the emergency stop, brake, overtravel, and other protective functions for the correct operation.	-
↓			
7	Input the Servo-ON signal	Input the Servo-ON signal, and turn ON the servomotor.	Host Reference
↓			
8	Input reference	Input the reference necessary for control mode, and check the servomotor for correct operation.	Host Reference
↓			
9	Protective operation	Turn the power OFF, and connect the servomotor to the machine. If using a servomotor equipped with an absolute encoder, set up the absolute encoder and make the initial settings for the host controller to match the machine's zero position.	-
↓			
10	Set necessary parameters.	Using the same procedure as you did to input a reference in step 8, operate the servomotor via the host controller and set the parameter to make sure the machine's travel direction, travel distance, and travel speed all correspond to the reference.	Host Reference
↓			
11	Operation	The servomotor can now be operated. Adjust the servo gain if necessary.	Host Reference

4.1.1 Trial Operation for Servomotor Without Load

CAUTION



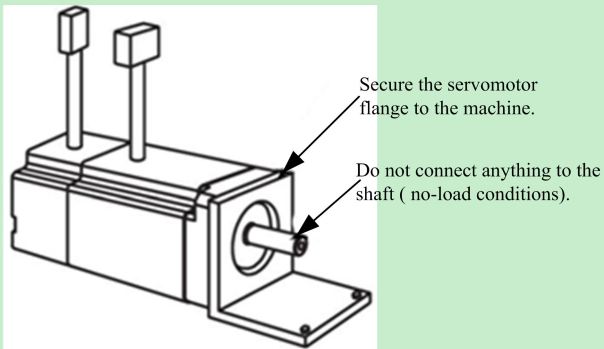
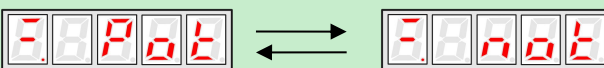

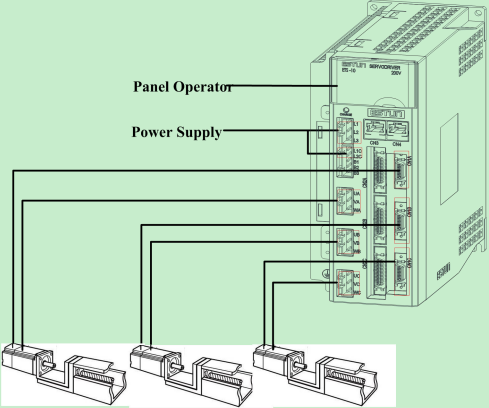

- Release the coupling between the servomotor and the machine, and secure only the servomotor without a load.
- To prevent accidents, initially perform the trial operation for servomotor under no-load conditions (with all couplings and belts disconnected).

In this section, confirm the cable connections of the main circuit power supply, servomotor and encoder. Incorrect wiring is generally the reason why servomotors fail to operate properly during the trial operation. Confirm the wiring, and then conduct the trial operation for servomotor without load according to the following steps.

Step	Description	Check Method and Remarks
1	<p>Secure the servomotor.</p> 	<p>Secure the servomotor flange to the machine in order to prevent the servomotor from moving during operation.</p> <p>Do not connect the servomotor shaft to the machine. The servomotor may tip over during rotation.</p>
2	<p>Check the power supply circuit, servomotor, and encoder wiring.</p>	<p>With the I/O signal connector (CN1_A/B/C) disconnected, check the power supply circuit and servomotor wiring.</p> <p>Refer to 3.1 Main Circuit Wiring.</p>
3	<p>Turn ON the control power supply and main circuit power supply.</p> <p>Normal Display</p>  <p>Alternate Display</p> <p>Example of Alarm Display</p> 	<p>If the power is correctly supplied, the panel operator display on the front panel of the servo drive will appear as shown on the left. The display on the left indicates that forward run prohibited (P-OT) and reverse run prohibited (N-OT).</p> <p>If an alarm display appears, the power supply circuit, servomotor wiring, or encoder wiring is incorrect. If an alarm is displayed, turn OFF the power, find the problem, and correct it.</p>
4	<p>When using a servomotor with a brake, release the brake first before driving the servomotor.</p>	<p>Please refer to 4.3.4 Setting for Holding Brakes</p> <p>Please refer to 4.4 Operating Using Speed Control with Internally Set Speed</p>

Step	Description	Check Method and Remarks
5		<p>Use the panel operator to operate the servomotor with utility function Fn002 (JOG Mode Operation). Check that the servomotor rotates in the forward direction by pressing the INC key, and reverse direction by pressing the DEC key.</p> <p>The operation is completed when the operation is performed as described below and the alarm display does not appear.</p> <p>Complete the Fn002 (JOG Mode Operation) and turn OFF the power.</p> <p>For the operation method of the panel operator, refer to Chapter 5 Panel Operator</p> <p>The servomotor speed can be changed using the Pn305 (JOG Speed). The factory setting for JOG speed is 500rpm.</p>

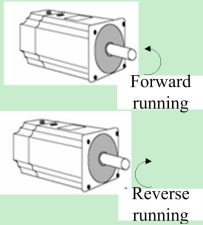
■ JOG Mode Operation (Fn002)

Step	Display after operation	Panel operator	Description
1		MODE key	Press the MODE key to select the function mode.
2		INC or DEC key	Press the INC key or DEC key to select Fn002.
3		ENTER key	Press the ENTER key, and the servomotor will enter JOG operation mode.
4		MODE key	Press the MODE key. This will turn ON the power to the servomotor.
5		INC or DEC key	The servomotor will run in forward direction when INC key is pressed or in reverse direction when DEC key is pressed. The servomotor will operate as long as the key is pressed.
6		MODE key	Press the MODE key. This will turn OFF the power to the servomotor.
7		ENTER key	Press the ENTER key to return to the Fn002 display of the utility function mode. Now, the servo drive is OFF.

Note:

The servomotor's rotation direction depends on the setting of parameter Pn001.0 (Direction Selection).

The example above describes operation with Pn001.0 in the factory setting.

Pn305	JOG Speed		Speed	Position
	Setting Range	Setting Unit	Factory Setting	Setting Validation
	0~6000	rpm	500	Immediately
Set the utility function Fn002 (JOG Mode Operation) to the reference value of servomotor speed.				

The servomotor can be operated using only the panel operator without reference from the host controller.

Please note that the Forward Run Prohibited (P-OT) and Reverse Run Prohibited (N-OT) signals are invalid during JOG mode operation.

4.1.2 Trial Operation for Servomotor without Load from Host Reference

Check that the servomotor move reference or I/O signals are correctly set from the host controller to the servo drive.

Also check the wiring and polarity between the host controller and servo drive, and the servo drive operation settings are correct. This is the final check before connecting the servomotor to the machine.

Operating Procedure in Position Control Mode (Pn005=H. □□1□)

The following circuits are required: External input signal circuit or equivalent.

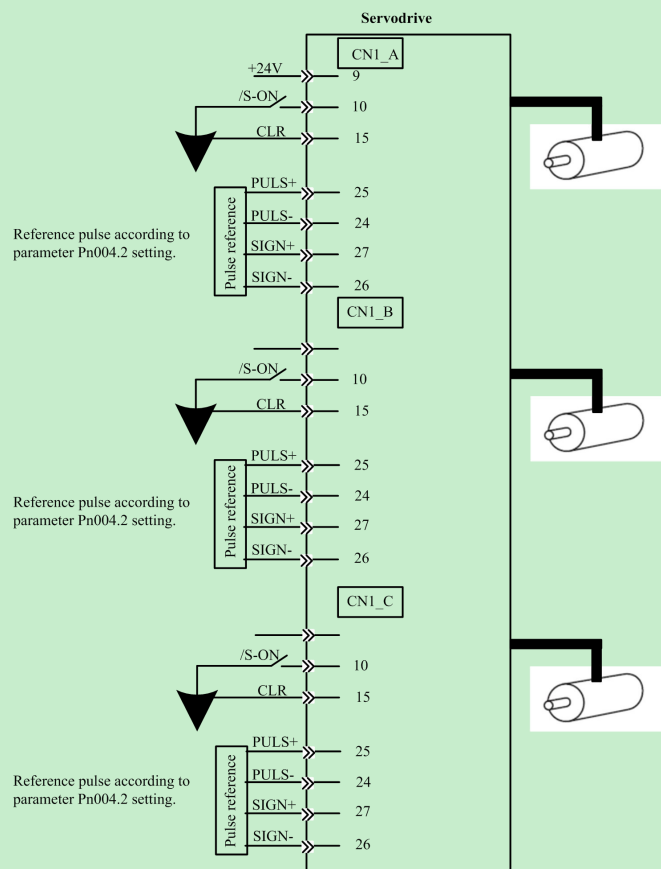

Step	Description	Check Method and Remarks
1	Match the reference pulse form with the pulse output form from the host controller.	Set the reference pulse form with Pn004.2.
2	Set the reference unit and electronic gear ratio so that it coincides with the host controller setting.	Set the electronic gear ratio with Pn201(or Pn203)/Pn202.
3	Turn the power and the servo ON input signal ON.	
4	Send the slow speed pulse reference for the number of servomotor rotation easy to check (for example, one servomotor revolution) from the host controller in advance.	Set the servomotor speed to 100rpm for the reference pulse speed because such speed is safe.
5	Check the number of reference pulses input to the servo drive by the changed amount before and after the Un013 and Un014(input reference pulse counter)[pulse] were executed.	Refer to 5.1.6 Operation in Monitor Mode for how it is displayed.
6	Check whether the actual number of servomotor rotations Un009、Un010 coincides with the number of input reference pulses.	Refer to 5.1.6 Operation in Monitor Mode for how it is displayed.
7	Check that the servomotor rotation direction is the same as the reference.	Check the input pulse polarity and input reference pulse form.
8	Input the pulse reference with the large number of servomotor rotation from the host controller to obtain the constant speed.	Set the servomotor speed to 100rpm for the reference pulse speed because such speed is safe.
9	Check the reference pulse speed input to the servo drive using the Un008 in Monitor Mode.(input reference pulse speed)[rpm].	Refer to 5.1.6 Operation in Monitor Mode for how it is displayed.
10	Check the servomotor speed using the Un000 in Monitor Mode.(servomotor speed) [rpm].	Refer to 5.1.6 Operation in Monitor Mode for how it is displayed.
11	Check the rotation of the servomotor shaft.	To change the servomotor rotation direction without changing the input reference pulseform, refer to 4.3.2 Switching the Servomotor Rotation Direction . Perform the operation from step 8 again after the servomotor rotation direction is changed.
12	When the pulse reference input is stopped and servo OFF status is entered, the trial operation for servomotor without load in position control mode is complete.	

4.1.3 Trial Operation with the Servomotor Connected to the Machine

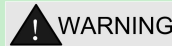

- Follow the procedure below for trial operation precisely as given.
- Malfunctions that occur after the servomotor is connected to the machine not only damage the machine, but may also cause an accident resulting in death or injury.

Follow the procedure below to perform the trial operation.

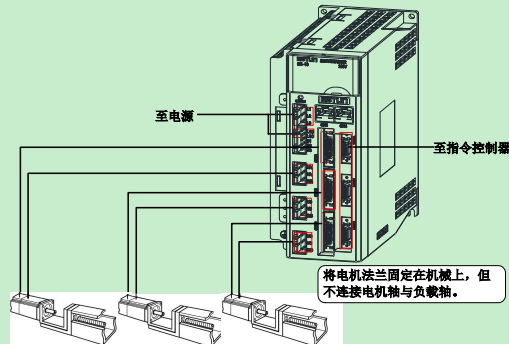

Step	Description	Check Method and Remarks
1	Turn the power ON, and make the settings for the mechanical configuration related to protective functions such as overtravel and brake.	Refer to 4.3 Setting Common Basic Functions . When a servomotor with brake is used, take advance measures to prevent vibration due to gravity acting on the machine or external forces before checking the brake operation. Check that both servomotor and brake operations are correct.
2	Set the necessary parameters for the control mode used.	Refer to 4.4 Operating Using Speed Control with Analog Reference , 4.5 Operating Using Position Control
3	Connect the servomotor to the machine with the coupling, etc., while the power is OFF.	
4	Check that the servo drive is servo OFF status and then turn ON the power to the machine (host controller). Check again that the protective function in step 1 operates normally.	Refer to 4.3 Setting Common Basic Functions . For the following steps, take advanced measures for an emergency stop so that the servomotor can stop safely when an error occurs during operation.
5	Perform trial operation with the servomotor connected to the machine, following each section in 4.1.2 Trial Operation for Servomotor without Load from Host Reference .	Check that the trial operation is completed according to the trial operation for servomotor without load. Also, check the settings for machine such as reference unit.
6	Check the parameter settings for control mode used in step 2.	Check that the servomotor rotates matching the machine operating specifications.
7	Adjust the servo gain and improve the servomotor response characteristics, if necessary.	The servomotor will not be broken in completely during trial operation. Therefore, let the system run for a sufficient amount of time to ensure that it is properly broken in.
8	Thus, the trial operation with the servomotor connected to the machine is complete.	

4.1.4 Trial Operation for Servomotor with Brakes

Holding brake operation of the servomotor can be controlled with the brake interlock output (/BK) signal of the servo drive. When checking the brake operation, take advance measures to prevent vibration due to gravity acting on the machine or external forces. Check the servomotor operation and holding brake operation with the servomotor separated from the machine. If both operations are correct, connect the servomotor to the machine and perform trial operation.

4.2 Control Mode Selection

The control modes supported by the ETS series servo drives are described below.

Parameter		Control Mode
Pn005	H. □□0□	<p>Speed Control (parameter reference)</p> <p>Controls servomotor speed using parameter reference. Use in the following instances.</p> <ul style="list-style-type: none"> • To control speed • For position control using the encoder feedback division output from the servo drive to form a position loop in the host controller.
	H. □□1□	<p>Position Control(Pulse train reference)</p> <p>Controls the position of the servomotor using pulse train position reference.</p> <p>Controls the position with the number of input pulses, and controls the speed with the input pulse frequency.</p> <p>Use when positioning is required.</p>
	H. □□2□	<p>Speed Control(contact reference) ↔ Speed Control (zero reference)</p> <p>Use the three input signals /P-CON, /P-CL and /N-CL to control the speed as set in advance in the servo drive.</p> <p>Three operating speeds can be set in the servo drive. (In this case, an analog reference is not necessary.)</p>
	H. □□3□ • • • H. □□5□	<p>These are switching modes for using the four control methods described above in combination. Select the control method switching mode that best suits the application.</p>

4.3 Setting Common Basic Functions

4.3.1 Setting the Servo ON Signal

This sets the servo ON signal (/S-ON) that determines whether the servomotor power is ON or OFF.

(1) Servo ON signal(/S-ON)

Type	Name	Connector Pin Number	Setting	Meaning
Input	/S-ON	CN1_A/B/C_10 (Factory setting)	ON(low level)	Servomotor power ON. Servomotor can be operated.
			OFF(high level)	Servomotor power OFF. Servomotor cannot be operated.

■ Important

Always input the servo ON signal before inputting the input reference to start or stop the servomotor.

Do not input the input reference first and then use the /S-ON signal to start or stop. Doing so will degrade internal elements and may cause the servo drive to malfunction.

A parameter can be used to re-allocate the input connector number for the /S-ON signal. Refer to **3.2.2 I/O Signal Names and Functions**.

(2) Enabling/Disabling the Servo ON Signal

A parameter can be always used to set the servo ON condition. This eliminates the need to wire /S-ON, but care must be taken because the servo drive can operate as soon as the power is turned ON.

Parameter	Meaning
Pn000	b. □□□0 External S-ON signal enabled (Factory setting)
	b. □□□1 External S-ON signal disabled, the servomotor excitation signal is opened automatically after outputting the S-RDY signal.

After changing these parameters, turn OFF the main circuit and control power supplies, and then turn them ON again to enable the new settings.

4.3.2 Switching the Servomotor Rotation Direction

The rotation direction of the servomotor can be switched without changing the reference pulse to the servo drive or the reference voltage polarity.

This causes the rotation the servo motor shaft is rotating to change. The output signal polarity, such as the encoder pulse output and the analog monitor signal from the servo drive do not change.

The standard setting for “forward rotation” is counterclockwise as viewed from the servomotor load end.

Parameter	Name	Reference	
		Forward reference	Reverse reference
Pn001	b.□□□0 Standard setting (CCW=forward) (factory setting)		
	b.□□□1 Reverse rotation mode (CW=forward)		
<p>The direction of P-OT and N-OT change. For Pn001=b.□□□0(standard setting), counterclockwise is P-OT. For Pn001=b.□□□1(reverse rotation mode), clockwise is P-OT.</p>			

4.3.3 Setting the Overtravel Limit Function

The overtravel limit function forces movable machine parts to stop if they exceed the allowable range of motion and turn ON a limit switch.

(1) Connecting the overtravel signal

To use the overtravel function, connect the following overtravel limit switch to the corresponding pin number of servo drive CN1_A/B/C connector correctly.

Type	Signal Name	Pin No.	Setting	Meaning
Input	P-OT	CN1_A/B/C_12 (factory setting)	ON(low level)	Forward rotation allowed. (Normal operation status.)
			OFF(high level)	Forward rotation prohibited. (Forward overtravel)
Input	N-OT	CN1_A/B/C_13 (factory setting)	ON(low level)	Reverse rotation (Normal operation status.)
			OFF(high level)	Reverse rotation prohibited. (Reverse overtravel)

Connect limit switches as shown below to prevent damage to the devices during linear motion.

Rotation in the opposite direction is possible during overtravel.

For example, reverse rotation is possible during forward overtravel.

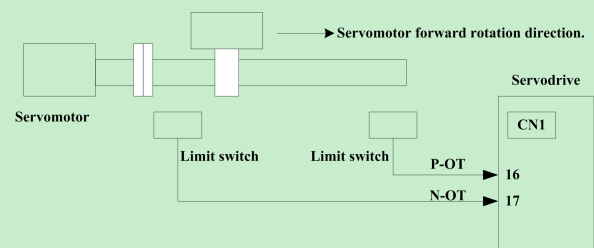

■ Important

When using overtravel to stop the servomotor during position control, the position error pulses are present. A clear signal(CLR)input is required to clear the error pulses.

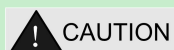

CAUTION

When using the servomotor on a vertical axis, the workpiece may fall in the overtravel condition.

To prevent this, always set the zero clamp after stopping with Pn004.0=5.

(2) Enabling/Disabling the Overtravel Signal

A parameter can be set to disable the overtravel signal. If the parameter is set, there is no need to wire the overtravel input signal.

Parameter		Meaning
Pn000	b. □□0□	Inputs the forward rotation prohibited(P-OT) signal fromCN1_A/B/C_12(factory setting).
	b. □□1□	Disables the forward rotation prohibited (P-OT) signal. (Allows constant forward rotation.)
	b. □0□□	Inputs the reverse rotation prohibited(N-OT) signal fromCN1_A/B/C_13.(factory setting)
	b. □1□□	Disables the reverse rotation prohibited(N-OT) signal. (Allows constant reverse rotation.)
<ul style="list-style-type: none"> • Applicable control modes: Speed control, position control, and torque control. • After changing these parameters, turn OFF the main circuit and control power supplies, and then turn them ON again to enable the new settings. • A parameter can be used to re-allocate input connector number for the P-OT and N-OT signals. Refer to 3.2.2 I/O Signal Names and Functions. 		

(3) Selecting the Servomotor Stop Method

This is used to set the stop method when an overtravel(P-OT,N-OT)signal is input while theservomotor is operating.

Parameter	Stop Mode	Mode After Stopping	Meaning	
Pn004	H. □□□0	Stop by dynamic brake	Coast	Rapidly stops the servomotor by dynamic braking(DB), then places it into coast(power OFF) mode.
	H. □□□1	Coast to a stop		Stops the servomotor in the same way as when the servo is OFF(coast to a stop), then places it into coast(power OFF) mode.
	H. □□□2	S-OFF /Overtravel	Coast	Stops the servomotor by dynamic braking (DB) when servo OFF, stops the servomotor by plug braking when overtravel, and then places it into coast (power OFF) mode.
	H. □□□3			Makes the servomotor coast to a stop state when servo OFF, stops the servomotor by plug braking when overtravel, and then places it into coast (power OFF) mode.
	H. □□□4		Zero Clamp	Stops the servomotor by dynamic braking (DB) when servo OFF, stops the servomotor by plug braking when overtravel, and then places it into zero clamp mode.
	H. □□□5			Makes the servomotor coast to a stop state when servo OFF, stops the servomotor by plug braking when overtravel, then places it into zero clamp mode.

- After changing these parameters, turn OFF the main circuit and control power supplies, and then turn them ON again to enable the new settings.
- Stop by dynamic brake: Stops by using the dynamic brake (short circuiting its electrical circuit).
- Coast to a stop: Stops naturally, with no brake, by using the friction resistance of the servomotor in operation.
- Plug braking: Stops by using plug braking limit torque.
- Zero Clamp Mode: A mode forms a position loop by using the position reference zero.

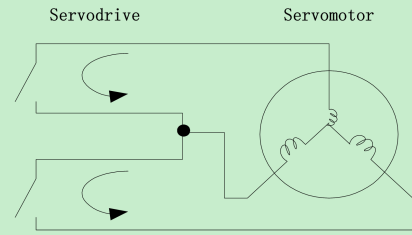

- Dynamic brake is an emergency stop function, and one of the general methods to cause a servomotor sudden stop.
- Dynamic brake suddenly stops a servomotor by shorting its electrical circuit.
- If the servomotor is frequently started and stopped by turning the power ON/OFF or using the servo ON signal(/S-ON), the DB circuit will also be repeatedly operated, degrading the servo drive's internal elements.
- Use the speed input reference and position reference to control the starting and the stopping of the servomotor.

(4)Setting the Stop Torque for Overtravel

Pn405	Plug braking torque limit`			
			Speed	Position
	Setting Range	Setting Unit	Factory Setting	Setting Validation
	0~300	%	300	Immediately

- This sets the stop torque for when the overtravel signal(P-OT,N-OT) is input.
- The setting unit is a percentage of the rated torque.(the rated torque is 100%)
- The value large enough to be the servomotor maximum torque, 300% is set as the factory setting for plug braking limit torque.However, the actual output plug braking limit torque is determined by servomotor ratings.

4.3.4 Setting for Holding Brakes

The holding brake is used when the servo drive controls a vertical axis.

A servomotor with the brake option helps prevent movable parts from shifting due to gravity when power is removed from the servo drive. (Refer to 4.1.4 Trial Operation for Servomotor with Brakes.)

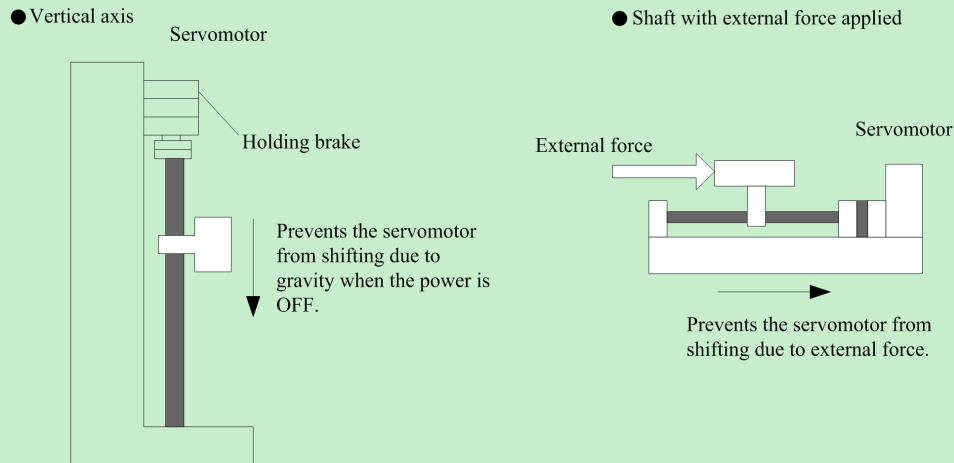

1. The servomotor with the built in brake, is a de-energization brake. It is used to hold the servomotor and cannot be used as a braking purposes. Use the holding brake only to hold a stopped servomotor.
2. When operating using only a speed loop, turn OFF the servo and set the input reference to 0V when the brake is applied.
3. When forming a position loop, do not use a mechanical brake while the servomotor is stopped because the servomotor enters servolock status.

(1) Wiring Example

Use the servo drive sequence output signal /BK and the brake power supply to form a brake ON/OFF circuit.

The following diagram shows a standard wiring example.

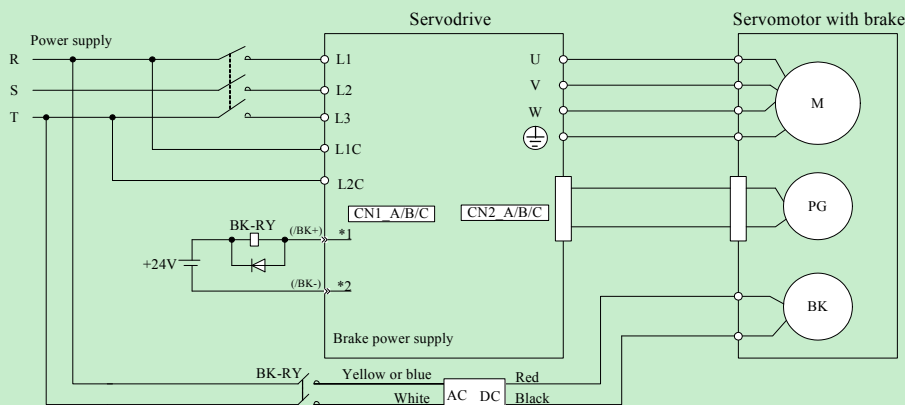

BK-RY: Brake control relay

*1、*2: The output terminals allocated with Pn511.

(2) Brake interlock output

Type	Signal Name	Connector Pin Number	Setting	Meaning
Output	/BK	Must be allocated	ON(Low level)	Releases the brake.
			OFF(High level)	Applies the brake.

This output signal controls the brake and is used only for a servomotor with a brake. This output signal is not used with the factory setting. The output signal must be allocated by Pn511. It does not need to be connected for servomotor without a brake.

(3) Allocating Brake Interlock Output (/Bk)

Brake interlock output (/BK) is not used with the factory setting. The output signal must be allocated.

Parameter		Connector Pin Number		Meaning
		+ Terminal	- Terminal	
Pn511	H.□□□4	CN1_A/B/C-11	CN1_A/B/C-12	The /BK signal is output from output terminal CN1_A/B/C-11,12.
Pn511	H.□□4□	CN1_A/B/C-5	CN1_A/B/C-6	The /BK signal is output from output terminal CN1_A/B/C -5,6.
Pn511	H.□4□□	CN1_A/B/C-9	CN1_A/B/C-10	The /BK signal is output from output terminal CN1_A/B/C -9,10.

■Important

When set to the factory setting, the brake signal is invalid.

For the allocation of servo drive output signals other than /BK signal, refer to **3.2.2 I/O Signal Names and Functions**.

Parameter Pn511 description as following:

0	/COIN(/V-CMP)output
1	/TGON rotation detecting output
2	/S-RDY servo drive get ready output
3	/CLT torque limit output
4	/BKbrake interlock output
5	/PGC encoder C pulse output
6	OT overtravel signal output
7	/RD servo enabled motor excitation output
8	/HOME home completion output

Related parameter:

Parameter No.	Name	Unit	Setting Range	Default
Pn505	Servo ON waiting time	ms	-2000~2000	0
Pn506	Basic waiting flow	10ms	0~500	0
Pn507	Brake waiting speed	rpm	10~100	100
Pn508	Brake waiting time	10ms	10~100	50

(4) Setting the Brake ON/OFF Timing after the Servomotor Stops

With the factory setting, the /BK signal is output at the same time as the servo is turned OFF. The servo OFF timing can be

changed with a parameter.

Pn505	Servo ON waiting time			
	Setting Range	Setting Unit	Factory Setting	Setting Validation
	-2000~2000	ms	0	Immediately
Pn506	Basic waiting flow			
	Setting Range	Setting Unit	Factory Setting	Setting Validation
	0~500	10ms	0	Immediately

·When using the servomotor to control a vertical axis, the machine movable parts may shift slightly depending on the brake ON/ OFF timing due to gravity or an external force. By using this parameter to delay turning the servo ON/ OFF, this slight shift can be eliminated.

·For details on brake operation while the servomotor is operating, refer to (5) Setting the Brake ON/ OFF Timing When Servomotor Running in this section.

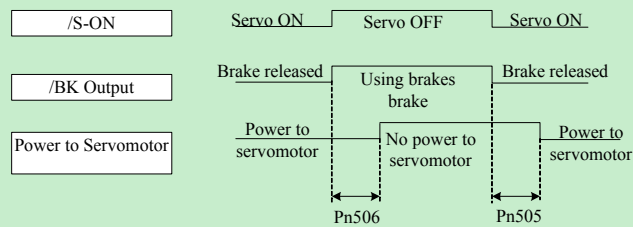

■Important

- The servomotor will turn OFF immediately when an alarm occurs, regardless of the setting of this parameter.
- The machine movable part may shift due to gravity or external force during the time until the brake operates.

(5) Setting the Brake ON/OFF Timing When Servomotor Running

The following parameters can be used to change the /BK signal output conditions when a stop reference is output during servomotor operation due to the servo OFF or an alarm occurring.

Pn507	Brake Waiting Speed		Speed	Position
	Setting Range	Setting Unit	Factory Setting	Setting Validation
	10~100	1rpm	100	Immediately
Pn508	Brake Waiting Time		Speed	Position
	Setting Range	Setting Unit	Factory Setting	Setting Validation
	10~100	10ms	50	Immediately

/BK Signal Output Conditions When Servomotor Running

The /BK signal goes to high level(brake ON) when either of the following conditions is satisfied:

- When the servomotor speed falls below the level set in Pn507 after servo OFF.
- When the time set in Pn508 is exceeded after servo OFF.

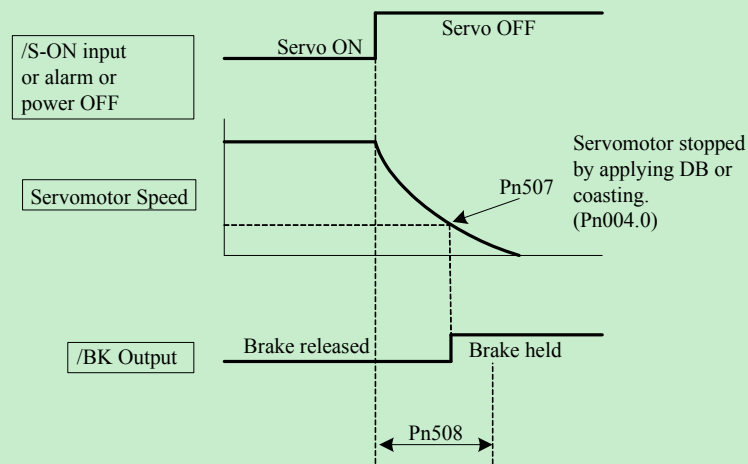

4.4 Operating Using Speed Control with Internally Set Speed

4.4.1 Setting Parameters

Parameter		Meaning
Pn005	H. □□0□	Control mode selection:Speed control(Internally set speed)(factory setting)

4.4.2 Soft Start

The soft start function converts the stepwise speed reference inside the servo drive to a consistent rate of acceleration and deceleration.

Pn310 can be used to select the soft start form:

0: Slope; 1: S curve; 2: 1st-order filter; 3: 2nd-order filter

Pn306	Soft Start Acceleration Time			Speed
	Setting Range	Setting Unit	Factory Setting	Setting Validation
	0~10000	1ms	0	Immediately
Pn307	Soft Start Deceleration Time			Speed
	Setting Range	Setting Unit	Factory Setting	Setting Validation
	0~10000	1ms	0	Immediately

The soft start function enables smooth speed control when inputting a stepwise speed reference or when selecting internally set speeds. Set both Pn306 and Pn307 to "0" for normal speed control.

Set these parameters as follows:

- Pn306: The time interval from the time the servomotor starts until the servomotor maximum speed is reached.
- Pn307: The time interval from the time the servomotor is operating at the servomotor maximum speed until it stops.

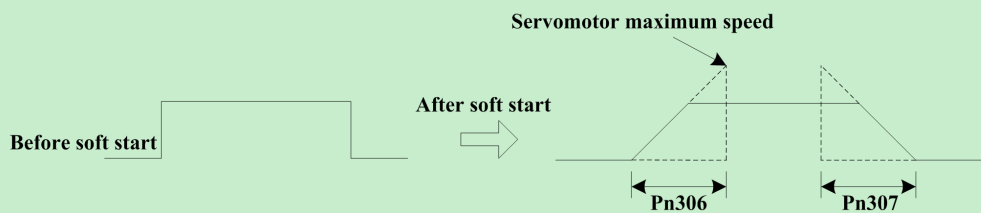

4.4.3 Speed Reference Filter Time Constant

Pn308	Speed Reference Filter Time Constant			Speed
	Setting Range	Setting Unit	Factory Setting	Setting Validation
	0~10000	1ms	0	Immediately

This smooths the speed reference by applying a 1st-order delay filter to the analog speed reference (V-REF) input. A value that is too large, however, will decrease response.

4.4.4 S-curve Risetime

Pn309	S-curve Risetime			Speed
	Setting Range	Setting Unit	Factory Setting	Setting Validation
	0~10000	1ms	0	Immediately

4.4.5 Encoder Signal Output

Encoder feedback pulses processed inside the servo drive can be output externally.

Type	Signal Name	Connector Pin Number	Name
Output	PAO+	34	Encoder output phase A
	PAO-	35	Encoder output phase /A
Output	PBO+	32	Encoder output phase B
	PBO-	33	Encoder output phase /B
Output	PCO+	30	Encoder output phase C(zero-point pulse)
	PCO-	31	Encoder output phase /C(zero-point pulse)

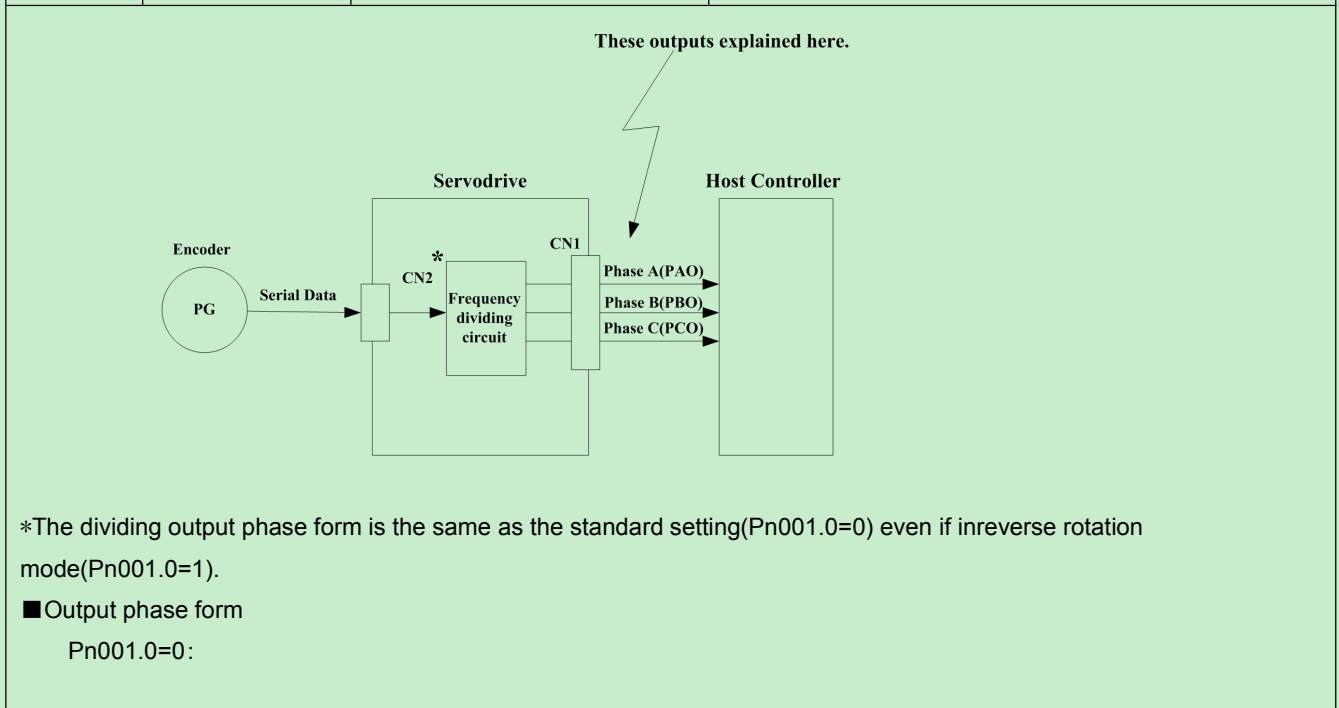

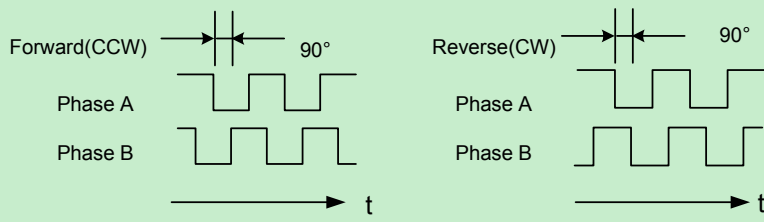

Pn001.0=1:

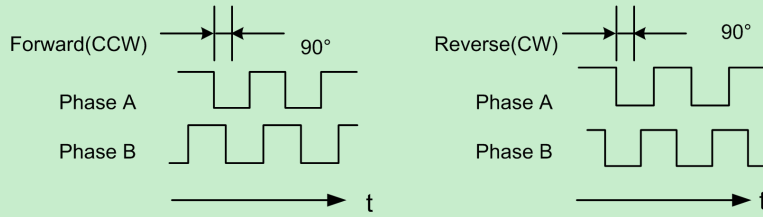

If the servomotor is not equipped with an absolute encoder, the servomotor needs two full rotations before using the servo drive's Phase-C pulse output as the zero point reference.

Dividing: Dividing means that the divider converts data into the pulse density (Pn200) based on the pulse data of the encoder installed on the servomotor, and outputs it. The setting unit is number of pulses/revolution.

■ Pulse Dividing Ratio Setting

Pn200	PG Dividing Ratio				Speed	Position
	Setting Range	Setting Unit	Factory Setting	Setting Validation		
	1~2500	Puls	2500	After restart		

Set the number of pulses for PG output signals(PAO,/PAO,PBO,/PBO) externally from the servo drive.
 Feedback pulses from the encoder per revolution are divided inside the servo drive by the number set in Pn200 before being output. (Set according to the system specifications of the machine or host controller.)
 The setting range varies with the number of encoder pulses for the servomotor used.

■ Output Example

Pn200=16(when 16 pulses are output per revolution)

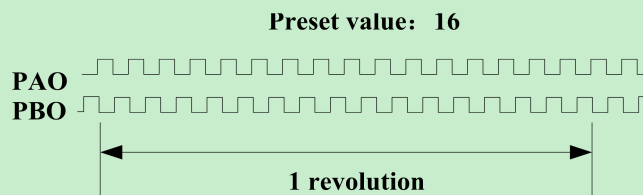

4.4.6 Speed coincidence output

The speed coincidence (/V-CMP) output signal is output when the actual servomotor speed during speed control is the same as the speed reference input. The host controller uses the signal as an interlock.

Type	Signal Name	Connector Pin Number	Setting	Meaning
Output	/V-CMP(/COIN)	CN1_A/B/C-11, 12 (factory setting)	ON(low level)	Speed coincides.
			OFF(high level)	Speed does not coincide.

Pn501	Coincidence Difference				Speed
	Setting Range	Setting Unit	Factory Setting	Setting Validation	
	0~100	rpm	10	Immediately	

The /V-CMP signal is output when the difference between the speed reference and actual servomotor speed is less than Pn501.

■ Example

The /V-CMP signal turns ON at 1900 to 2100rpm if the Pn501 parameter is set to 100 and the reference speed is 2000rpm.

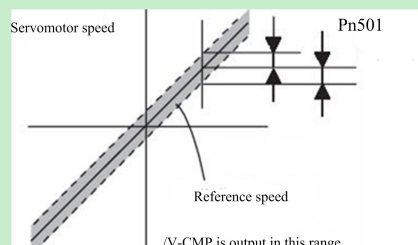

■ Note

This pin outputs the /COIN signal in position control mode, and the /V-CMP signal in speed control mode.

4.4.7 Speedcontrol(contactreference)

The function of internally set speed selection allows speed control operation by externally selecting an input signal from among seven servomotor speed setting made in advance with parameters in the servo drive. The speed control operations within the three settings are valid. There is no need for an external speed or pulse generator.

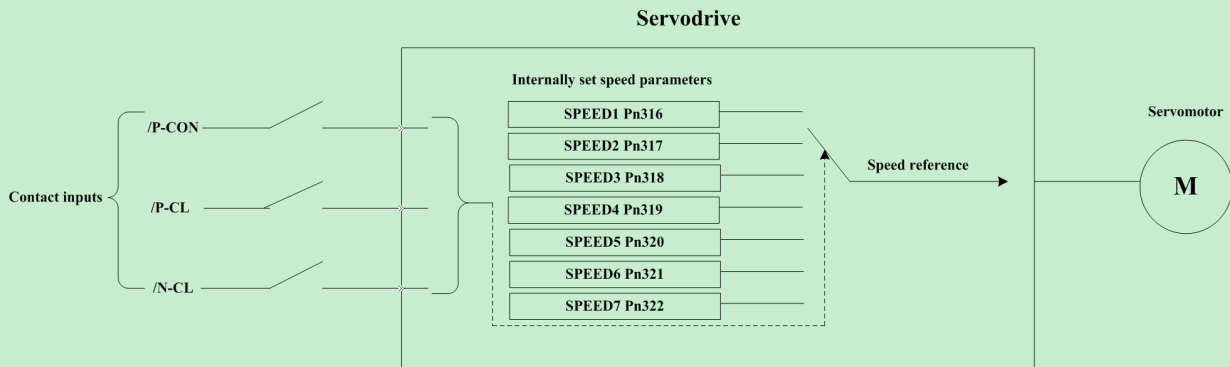

■Parameters setting

Parameter		Meaning
Pn005	H. <input type="checkbox"/> <input type="checkbox"/> <input type="checkbox"/> <input type="checkbox"/>	Control mode selection:Speed control(contact reference)

Pn316	Internal set speed 1			speed
	Setting Range	Setting Unit	Factory Setting	Setting Validation
	-6000~6000	rpm	100	Immediately
Pn317	Internal set speed 2			speed
	Setting Range	Setting Unit	Factory Setting	Setting Validation
	-6000~6000	rpm	200	Immediately
Pn318	Internal set speed 3			speed
	Setting Range	Setting Unit	Factory Setting	Setting Validation
	-6000~6000	rpm	300	Immediately
Pn319	Internal set speed 4			speed
	Setting Range	Setting Unit	Factory Setting	Setting Validation
	-6000~6000	rpm	-100	Immediately
Pn320	Internal set speed 5			speed
	Setting Range	Setting Unit	Factory Setting	Setting Validation
	-6000~6000	rpm	-200	Immediately
Pn321	Internal set speed 6			speed
	Setting Range	Setting Unit	Factory Setting	Setting Validation
	-6000~6000	rpm	-300	Immediately

Pn322	Internal set speed 7			speed
	Setting Range	Setting Unit	Factory Setting	Setting Validation
	-6000~6000	rpm	500	Immediately

(Note):The servomotor's maximum speed will be used whenever a speed setting for the Pn316~Pn322 exceeds the maximum speed.

■ Control mode switching

Use ON/OFF combinations of the following input signals to operate with the internally set speeds.

When Pn005.1=2: Selects the internally set speed (contact reference) ↔ control (zero reference)

Input Signal			Speed
/P-CON	/P-CL	/N-CL	
OFF(H)	OFF(H)	OFF(H)	Speed control (zero reference)
	OFF(H)	ON(L)	SPEED1
	ON(L)	OFF(H)	SPEED2
	ON(L)	ON(L)	SPEED3
ON(L)	OFF(H)	OFF(H)	SPEED4
	OFF(H)	ON(L)	SPEED5
	ON(L)	OFF(H)	SPEED6
	ON(L)	ON(L)	SPEED7

Note: OFF= High level; ON= Low level

When Pn005.1 = 3, /P-CON, /PCL, /NCL =OFF(H), switches to position control(pulse train reference)

Input Signal			Speed
/P-CON	/PCL	/NCL	
OFF(H)	OFF(H)	OFF(H)	Position control(pulse train reference)
	OFF(H)	ON(L)	SPEED1
	ON(L)	OFF(H)	SPEED2
	ON(L)	ON(L)	SPEED3
ON(L)	OFF(H)	OFF(H)	SPEED4
	OFF(H)	ON(L)	SPEED5
	ON(L)	OFF(H)	SPEED6
	ON(L)	ON(L)	SPEED7

4.5 Operating Using Position Control

4.5.1 Basic Setting in Position Control

(1)Control mode selection

Set the following parameters for position control using pulse trains.

Parameter		Meaning
Pn005	H. <input type="checkbox"/> <input type="checkbox"/> <input type="checkbox"/> <input type="checkbox"/>	Control mode selection: position control(pulse train reference)

(2)Setting a reference pulse sign

Type	Signal Name	Connector Pin Number	Name
Input	PULS+	CN1_A/B/C-25	Reference pulse input
	PULS-	CN1_A/B/C-24	Reference pulse input
	SIGN+	CN1_A/B/C-27	Reference sign input
	SIGN-	CN1_A/B/C-26	Reference sign input

Set the input form for the servo drive using parameter Pn004.2 according to the host controller specifications.

Parameter		Reference Pulse Form	Input Pulse Multiplier	Forward Rotation Reference	Reverse Rotation Reverse
Pn004	H. <input type="checkbox"/> <input type="checkbox"/> <input type="checkbox"/> <input type="checkbox"/>	Sign+pulse train (positive logic) (factory setting)	—		
	H. <input type="checkbox"/> <input type="checkbox"/> <input type="checkbox"/> <input type="checkbox"/>	CW+CCW (positive logic)	—		
	H. <input type="checkbox"/> <input type="checkbox"/> <input type="checkbox"/> <input type="checkbox"/>	Two-phase pulse train with 90° phase differential (positive logic)	×1		
	H. <input type="checkbox"/> <input type="checkbox"/> <input type="checkbox"/> <input type="checkbox"/>		×2		
H. <input type="checkbox"/> <input type="checkbox"/> <input type="checkbox"/> <input type="checkbox"/>		×4			

■Note:

The input pulse multiplier can be set for the two-phase pulse train with 90° phase differential reference pulse form.

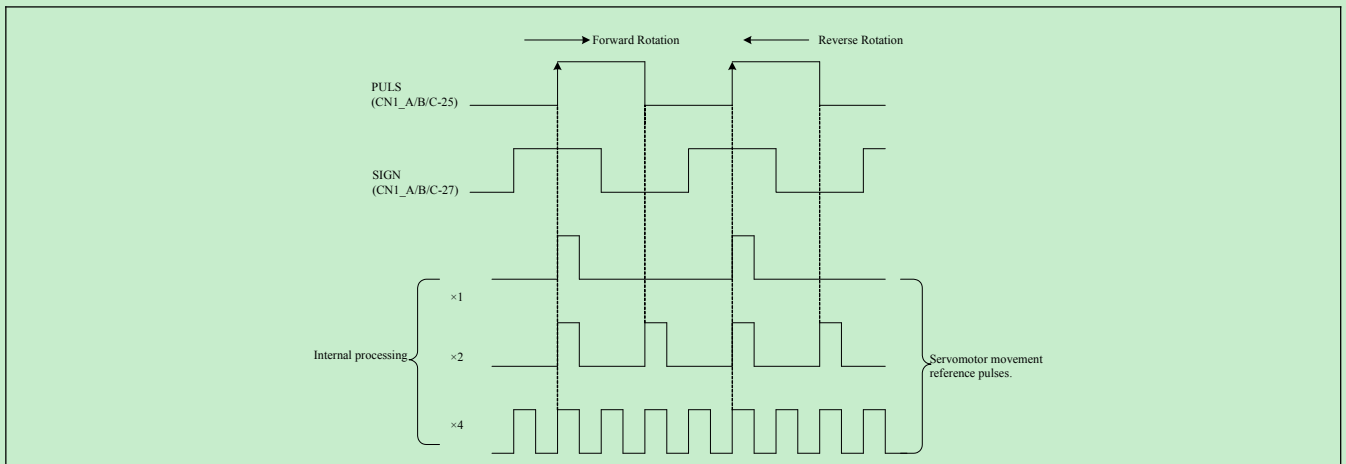

(3) Inverse PULS and SIGN reference

Pn004	0□□□	Do not invert PULS reference and SIGN reference
	1□□□	Do not invert PULS reference; Invert SIGN reference
	2□□□	Invert PULS reference; Do not invert SIGN reference
	3□□□	Invert PULS reference and SIGN reference

4.5.2 Setting the Clear Signal

(1) Setting the Clear Signal

Type	Sign Name	Connector Pin Numbe	Function
Input	/CLR	CN_A/B/C-40	error counter clear

When the /CLR signal is set to low level, clear error counter:

- The error counter inside the servo drive is set to "0"
- Position loop operation is disabled.

(2) Setting the Clear SignalMode

In position control mode, pulses will be still presented in the servo drive when servo OFF, thus it should be cleared when servo drive is turned ON. Setting Pn004 to choose whether clearing the pulses automatically when servo OFF.

Pn004	<input type="checkbox"/> <input type="checkbox"/> 0 <input type="checkbox"/>	Clear the error pulse when S-OFF, donot when overtravel.
	<input type="checkbox"/> <input type="checkbox"/> 1 <input type="checkbox"/>	Do not clear the error pulse.
	<input type="checkbox"/> <input type="checkbox"/> 2 <input type="checkbox"/>	Clear the error pulse when S-OFF overtravel (except for zero clamp)

4.5.3 Setting the Electronic Gear

(1) Electronic Gear

The electronic gear enables the workpiece travel distance per input reference pulse from the host controller to be set to any value.

One reference pulse from the host controller, i.e., the minimum position data unit, is called a reference unit.

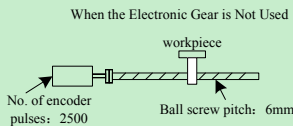

To move a workpiece 10mm :

One revolution is 6mm. Therefore $10 \div 6 = 1.6666$ revolutions.
2500×4 pulses is one revolution.
Therefore, $1.6666 \times 2500 \times 4 = 16666$ pulses. 16666 pulses are input as reference pulses.
The equation must be calculated at the host controller.

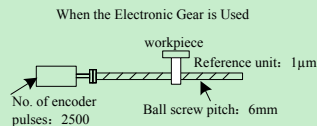

To move a workpiece 10mm using reference units:

The reference unit is 1µm. Therefore, to move the workpiece 10mm (10000µm), 1 pulse=1µm, so $10000 \div 1 = 10000$ pulses. Input 10000 pulses per 10mm of workpiece movement.

(2) Related Parameters

Pn201	Electronic Gear Ratio(Numerator)			Position
	Setting Range	Setting Unit	Factory Setting	Setting Validation
	1~65535	—	1	After restart
Pn202	Electronic Gear Ratio(Denominator)			Position
	Setting Range	Setting Unit	Factory Setting	Setting Validation
	1~65535	—	1	After restart

The deceleration ratio of the servomotor and the load shaft is given as m/n where m is the rotation of the servomotor and n is the rotation of the load shaft.

$$\begin{aligned} \text{Electronic gear ratio: } \frac{B}{A} &= \frac{Pn201}{Pn202} \\ &= \frac{\text{No. of encoder pulses} \times 4}{\text{Travel distance per load shaft revolution (reference units)}} \times \frac{m}{n} \end{aligned}$$

- If the ratio is outside the setting range, reduce the fraction (both numerator and denominator) until you obtain integers within the range.
- Be careful not to change the electronic gear ratio (B/A).

■ Important

- Electronic gear ratio setting range: $0.01 \leq \text{electronic gear ratio}(B/A) \leq 100$
- If the electronic gear ratio is outside this range, the servo drive will not operate properly. In this case, modify the load configuration or reference unit.

(3) Procedure for Setting the Electronic Gear Ratio

Use the following procedure to set the electronic gear ratio.

Step	Operation	Description
1	Check machine specifications.	Check the deceleration ratio, ball screw pitch and pulley diameter.
2	Check the number of encoder pulses.	Check the number of encoder pulses for the servomotor used.
3	Determine the reference unit used.	Determine the reference unit from the host controller, considering the machine specifications and positioning accuracy.
4	Calculate the travel distance per load shaft revolution.	Calculate the number of reference units necessary to turn the load shaft one revolution based on the previously determined reference units.
5	Calculate the electronic gear ratio.	Use the electronic gear ratio equation to calculate the ratio (B/A).
6	Set parameters.	Set parameters using the calculated values.

(4)Electronic Gear Ratio Setting Examples

The following examples show electronic gear ratio settings for different load configurations.

Step	Operation	Load Configuration					
		Ball Screw		Disc Table		Belt and Pulley	
1	Check machine specifications.	Ball screw pitch:mm Deceleration ratio:1/1		Rotation angle per revolution :360° Deceleration ratio:3/1		Pulley diameter:100 mm (pulley circumference:314 mm) ·Deceleration ratio:2/1	
2	Encoder	Wire-saving incremental encoder 2500P/R		Wire-saving incremental encoder 2500P/R		Wire-saving incremental encoder 2500P/R	
3	Determine the reference unit used	1 reference unit: 0.001mm(1μm)		1 reference unit:0.1°		1 reference unit:0.01mm	
4	Calculate the travel distance per load shaft revolution	6mm/0.001mm=6000		360°/0.1°=3600		314mm/0.01mm=31400	
5	Calculate the electronic gear ratio	$\frac{B}{A} = \frac{2500 \times 4}{6000} \times \frac{1}{1}$		$\frac{B}{A} = \frac{2500 \times 4}{3600} \times \frac{3}{1}$		$\frac{B}{A} = \frac{2500 \times 4}{31400} \times \frac{2}{1}$	
6	Set parameters	Pn201	10000	Pn201	30000	Pn201	20000
		Pn202	6000	Pn202	3600	Pn202	31400
7	Final Result	Pn201	5	Pn201	25	Pn201	100
		Pn202	3	Pn202	3	Pn202	157

- Reduce the fraction (both numerator and denominator) if the calculated result will not be within the setting range.
- For example, reduce the above numerators and denominators by four or other numbers to obtain the final results in step 7 and complete the settings.

(5)Electronic Gear Ratio Equation

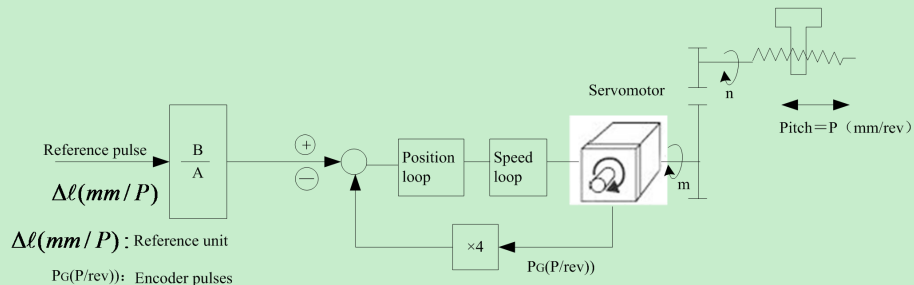

$\Delta l(\text{mm}/P)$: Reference unit

$P_G(P/\text{rev})$: Encoder pulses

P (mm/rev) : Ball screw pitch

$\frac{m}{n}$: Deceleration ratio

$$\frac{n \times p}{\Delta l} \times \left(\frac{B}{A}\right) = 4 \times P_G \times m$$

$$\left(\frac{B}{A}\right) = \frac{4 \times P_G \times m \times \Delta l}{n \times p} = \frac{4 \times P_G}{P} \times \frac{m}{n}$$

Set A and B with the following parameters:

A : Pn202 **B** : Pn201

4.5.4 Smoothing

A filter can be applied in the servo drive to a constant-frequency reference pulse.

(1) Selecting a Position Reference Filter

Parameter	Description
Pn205	0: 1 st -order filter
	1: 2 nd -order filter

* After changing the parameter, turn OFF the power once and turn it ON again to enable the new setting.

(2) Filter-related Parameters

Pn204	Position Reference Acceleration/Deceleration Time Constant				Position
	Setting Range	Setting Unit	Factory Setting	Setting Validation	
	0~32767	0.25ms	0	Immediately	

■ Important

When the position reference acceleration/deceleration time constant (Pn204) is changed, a value with no reference pulse input and a position error of 0 will be enabled. To ensure that the setting value is correctly reflected, stop the reference pulse from the host controller and input the clear signal (CLR), or turn OFF to clear the error.

This function provides smooth servomotor operation in the following cases.

- When the host controller that outputs a reference that cannot perform acceleration/deceleration processing.
- When the reference pulse frequency is too low.
- When the reference electronic gear ratio is too high (i.e., 10× or more)

4.5.5 Low Frequency Vibration Suppression

(1) Note:

For the low rigidity load, low frequency vibration will occur continually at the front end of the load during fast acceleration or fast deceleration. The vibration may delay positioning time and affect the productive efficiency.

The function of low frequency vibration suppression is embedded in ETS series servo drives by calculating the load position and compensating.

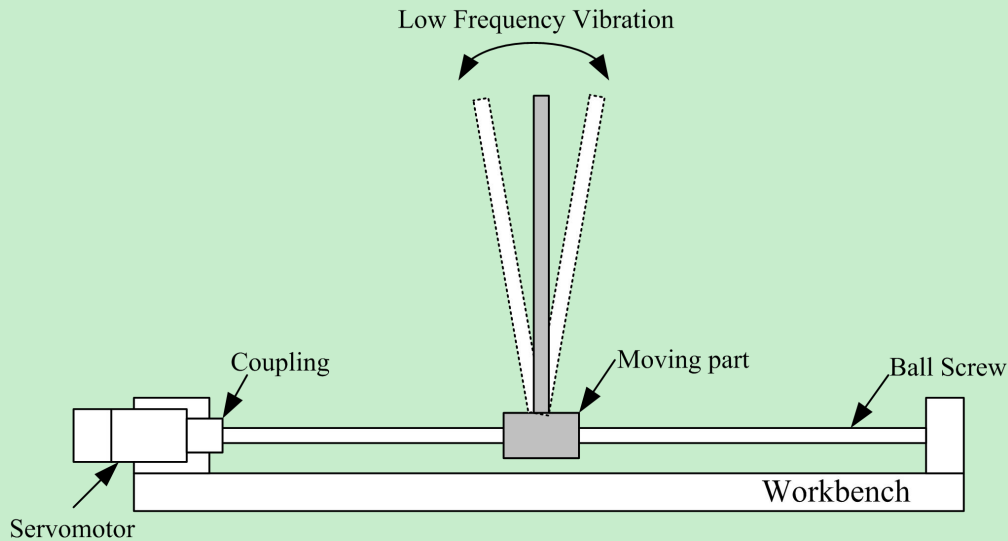

(2) Application:

Low frequency vibration suppression function is enabled in both speed control mode and position control mode.

Low frequency vibration suppression function is disabled or can not reach the expected effect in the following conditions.

- Vibration is picked up due to an external force.
- Vibration frequency is between 5.0Hz to 50.0Hz.
- There is mechanical clearance at the mechanical connection part.
- The time for movement is less than one vibration period.

(3) How to operate:

■ Measuring Vibration frequency

Write the frequency data measured (unit: 0.1Hz) directly to Parameter Pn411, if the vibration frequency can be measured by an instrument (such as a laser interferometer). And it also can be measured indirectly by communication software ESView or FFT analysis function.

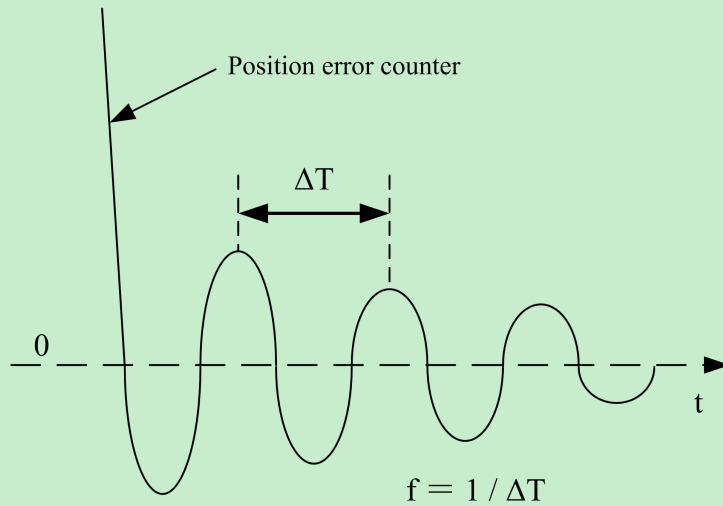

■ Related Parameters

Parameter		Meaning
Pn006	H. <input type="checkbox"/> 0 <input type="checkbox"/> <input type="checkbox"/> <input type="checkbox"/>	0:Low frequency vibration suppression function disabled
	H. <input type="checkbox"/> 1 <input type="checkbox"/> <input type="checkbox"/> <input type="checkbox"/>	1:Low frequency vibration suppression function enabled

Pn411	Low frequency vibration frequency		<input type="checkbox"/> Speed	<input type="checkbox"/> Position
	Setting Range	Setting Unit	Factory Setting	Setting Validation
	50~500	0.1Hz	100	Immediately
Pn412	Low frequency vibration damp		<input type="checkbox"/> Speed	<input type="checkbox"/> Position
	Setting Range	Setting Unit	Factory Setting	Setting Validation
	0~200	—	25	Immediately

- Writing the frequency data to parameter Pn411 can adjust Pn411 slightly to obtain the best suppression effect.
- If the servomotor stopped with continuous vibration, Pn412(Do not change in general) should be increased properly.
- Parameter Pn411 and Pn412 are enabled when Pn006.2=1(Setting validation: after restart).

4.5.6 Positioning Completion Output Signal

This signal indicates that servomotor movement has been completed during position control. Use the signal as an interlock to confirm that positioning has been completed at the host controller.

Type	Signal Name	Connector Pin Number	Setting	Meaning
Output	/COIN	CN1_A/B/C-11, CN1_A/B/C-12 (Factory setting)	ON(low level)	Positioning has been completed.
			OFF(high level)	Positioning is not completed.

• This output signal can be allocated to an output terminal with parameter Pn511. Refer to **3.2.2 I/O Signal Names and Functions**.

Pn500	Positioning Error			Position
	Setting Range	Setting Unit	Factory Setting	Setting Validation
	0~5000	1Puls	10	Immediately
Pn520	Position complete time			Position
	Setting Range	Setting Unit	Factory Setting	Setting Validation
	0~60000	0.25ms	500	Immediately

- The positioning completion (/COIN) signal is output when the difference (position error pulse) between the number of reference pulses output by the host controller and the travel distance of the servomotor is less than the value set in this parameter and the stabilization time is more than the value of Pn520.
- Set the number of error pulses in reference unit (the number of input pulses defined using the electronic gear).
- Too large a value at this parameter may output only a small error during low-speed operation that will cause the /COIN signal to be output continuously.
- The positioning error setting has no effect on final positioning accuracy.

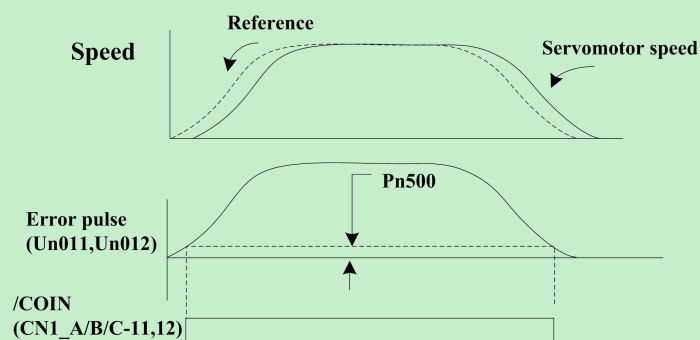

■ Note

- /COIN is a position control signal.
- This signal is used for the speed coincidence output /V-CMP for speed control, and it always OFF(high level) for torque control.

4.5.7 Reference Pulse Inhibit Function(INHIBIT)

(1)Description

This function inhibits the servo drive from counting input pulses during position control.

The servomotor remains locked (clamped) while pulses are inhibited.

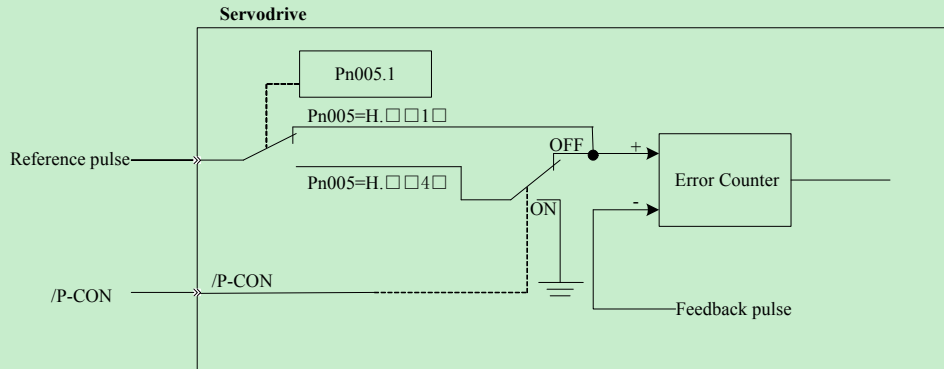

(2)Setting Parameters

Parameter		Meaning
Pn005	H. □□4□	Control mode selection: position control(pulse train reference)⇔INHIBIT
<p>■ Inhibit(INHIBIT) switching condition</p> <ul style="list-style-type: none"> • /P-CON signal ON (low level) 		

(3)Setting Input Signals

Type	Signal Name	Connector Pin Number	Setting	Meaning
Input	/P-CON	CN1_A/B/C-11	ON(low level)	Turns the INHIBIT function ON. (Inhibit the servo drive from counting reference pulses)
			OFF(high level)	Turns the INHIBIT function OFF. (Counts reference pulses.)

4.5.8 Position Control (contact reference)

Position control under contact reference (parameter Pn005.1=5). In this mode, servo drive can position with a single axes

without a host controller.

There are 16 position control points with each being able to set move distance, running speed, constants for position reference filter time, and the stop time when positioning completed. Two speeds (1. speed moving toward distance switch “speed of looking for reference point”. 2. Speed moving away from distance switch “moving speed.”) of reference points could be set as:

Two position modes: 1. Absolute position mode 2. Relative position mode

Two running modes: 1. Circling mode 2. Non-circling mode

Two step switching method: 1. Delay step switching 2. /P-CON signal switching

Method of looking for reference points: 1. Forward direction 2. Reverse direction

▪ **Adjusting offset**

Offset of each points has two correspondent parameters: one unit of the parameter is 【x 10000 reference pulse】 and the other is 【x 1 reference pulse】. Setting range of both parameters is: (-9999----+9999), while offset value equals sum of those two values.

For example:

No.0 offset correspond to parameter Pn600 【x 10000 reference pulse】 and Pn601 【x 1 reference pulse】. Set Pn600 = 100, Pn601=-100.

$$\begin{aligned} \text{No.0 offset value} &= \text{Pn600} \times 10000 \text{ reference pulse} + \text{Pn601} \times 1 \text{ reference pulse} \\ &= 100 \times 10000 \text{ reference pulse} + (-100) \times 1 \text{ reference pulse} \\ &= 999900 \text{ reference pulse} \end{aligned}$$

With the same principle, we can conclude: in order to get the same results, we also can set Pn600 = 99 and Pn601 = 9900.

Thus, we can see when the two parameters are not zero; we can get same result by two ways: one is to set the two parameters both negative or both positive, or one negative the other positive.

▪ **Speed**

Speed mentioned here refers to the steady speed during which the motor is running, which is similar to the pulse frequency given from the external pulse reference in position control. However, this speed has nothing to do with the electronic gear; it is the actual speed of the motor.

▪ **Position reference filter time constant**

Same as position reference filter time constant Pn204 in common position control.

▪ **Time for change steps after desired position reached**

Apply internal delay to change steps to a valid value in parameter Pn681.1.

Time for change steps outputs from positioning completed signal CON/, from Servo ON, or from the time when reference point is found till the Servo performs the program to control position of the point. Such period of time depends on step changing time required by a point number among start point in program.

When running point control program, if error counter is set as “not clear error counter when Servo OFF”, then the error counter might flood. If it does not flood, then the servo drive will probably run at the max. running speed when Servo ON again. **PLEASE PAY ATTENTION TO THE SAFETY OF INSTRUMENT.**

Para. No.	Name and description	Setting range	Default
Pn004.1	[0] Clear error pulse when S-OFF, not clear error pulse when overtravel.	0~2	0

	[1] Not clear error pulse		
	[2] Clear error pulse When S-OFF or over travel		

▪ Looking for the reference point

Looking for the reference point is for establishing a zero physical point of the operating platform, which is used as zero point in the coordinates during point position control. And users may choose to find a reference point either in forward or reverse side.

How to find a reference point

Mount a limit switch in the forward or reverse side. Find a reference point in the forward direction after connecting to /PCL and in the reverse direction after connecting to /NCL. When the operating platform bumps into the limit the switch, the motor will first stop according to the way set by Pn004.0, and then rotate again against limit the switch. When the operating platform leaves the limit switch and the motor reaches the position of first photo encoder Phase C pulse, then position of operating platform is set to be the zero point of the coordinates.

How to find related parameters of reference point

Speed towards limit switch is called “speed of looking for reference point”, and the moving speed away from limit switch is called “moving speed”. These two speeds could be set by the following parameters:

Para. No.	Description	Unit	Setting range	Default
Pn685	Speed of looking for reference point (hits the limit switch)	rpm	0~3000	1500
Pn686	Moving speed (move away from limit switch)	rpm	0~200	30

Usually, the set speed of the reference point (Pn685) is high, and the moving speed (Pn686) is low. Note: if moving speed is too high, precision of finding a reference point would be affected.

When looking for a reference point, /PCL and /NCL are no longer programmed to limit external current.

■ Related parameter

Para. No.	Description	Observation
Pn681.0	<p>Choose between cycle run and single run.</p> <p>0: Cycle run, /PCL as start signal, /NCL reverse to look for reference point.</p> <p>1: Single run, /PCL as start signal, /NCL reverse to look for reference point.</p> <p>2. Cycle run, /NCL as start signal, /PCL reverse to look for reference point.</p> <p>3. Single run, /NCL as start signal, /PCL reverse to look for reference point.</p>	<p>Changing steps will be performed till the end point is completed comma and the next change will start from the start point during multi-points cycle run.</p> <p>Point control program will not change steps after the end point is completed during multi- points single run.</p>
Pn681.1	<p>Change step and start mode</p> <p>0: Delay changing steps, the start signal is not needed.</p> <p>1: Change steps by /P-CON, start signal not needed.</p> <p>2. Delay changing steps, need start signal.</p> <p>3. Change steps by /P-CON, need start signal.</p>	<p>Change steps by external /P-CON signals. The signal will be valid when drive output reaches the desired position. When input signal changes, the signal is valid, then steps will be changed by consequence from start point to end point.</p>
Pn681.2	<p>Change step input signal mode</p> <p>[0] High or low level</p> <p>[1] sign pulse</p>	
Pn682	<p>0: Incremental</p> <p>1: Absolute</p>	<p>Incremental: relative moving distance (distance from current point to next point) programming.</p> <p>Absolute: absolute moving distance (distance between operating platform and the reference point) programming.</p>

4.5.9 Position Homing Control (Homing Function)

In position control mode, the servomotor always needs to operate at a fixed position. This position is normally regarded as the zero position. When the host controller is turned on, the zero position adjustment is required before processing. This zero position will be regarded as the reference point. ESTUN servo drives can perform this function by the homing function.

(1)Homing Mode Setting

Para. No.	Description	
Pn689	b. □□□0	Homing in the forward direction
	b. □□□1	Homing in the reverse direction
	b. □□0□	Return to search C-Pulse when homing
	b. □□1□	Directly search C-Pulse when homing
	b. □0□□	Homing function disabled
	b. □1□□	Homing triggered by SHOM signal(rising edge)
<ul style="list-style-type: none"> • Applicable control mode:position control • Homing operation can only be operated when /COIN is ON. • Pulses sent from the host controller is disabled when homing • Homing operation is disabled when in switching control mode. • Control mode switching is not allowed during homing. • After changing these parameters, turn OFF the main circuit and control power supplies and then turn them ON again to enable the new settings. • A parameter can be used to re-allocate input connector number for the SHOM and ORG signals. Refer to 3.2.3 I/O Signal Names and Functions. 		

(2)Related parameter:

Pn685	Speed of finding reference point(Hitting the origin signal ORG)			
	Setting Range	Setting Unit	Factory Setting	Setting Validation
	0~3000	rpm	1500	Immediately
Pn686	Speed of finding reference point(Leaving the origin signal ORG)			
	Setting Range	Setting Unit	Factory Setting	Setting Validation
	0~200	rpm	30	Immediately
Pn690	Number of error pulses during homing			
	Setting Range	Setting Unit	Factory Setting	Setting Validation
	0~9999	10000 puls	0	Immediately
Pn691	Number of error pulses during homing			
	Setting Range	Setting Unit	Factory Setting	Setting Validation
	0~9999	1 puls	0	Immediately

(3)Input Signal Setting

Type	Signal	Connector Pin	Setting	Meaning
Input	SHOM	Must be allocated by Pn509,Pn510	ON= ↑ (rising edge)	Homing is enabled
			OFF(not rising edge)	Homing is disabled
Input	ORG	Must be allocated by Pn509,Pn510	ON=H	ORG is enabled
			OFF=L	ORG is disabled
Input	/HOME	Must be allocated by Pn511	ON=L	Homing completed
			OFF=H	

• After changing Pn509, Pn510 and Pn511 turn OFF the main circuit and control power supplies and then turn them ON again to enable the new settings.

(4)Description of Homing Operation

Please set Pn689 according to the actual operation in position control mode. When starting the homing function, the servomotor will run at the speed of Pn685 when detecting the rising edge of SHOM signal; the servomotor will run at the speed of Pn686 according to the setting of Pn689.1 when detecting the valid ORG signal.

When input ORG and the encoder C-Pulse is detected, the servo drive will begin to calculate the number of homing offset pulses. When offset pulses is completed, the servomotor stops and outputs homing completion signal /HOME, then homing control is completed.

Pn685 (Hitting the origin signal (ORG)) is usually set at high speed, Pn686 (Leaving the origin signal ORG) is usually set at low speed.

Please be attention that if Pn686 is setting too high, the precision of mechanical zero position will be affected.

After hitting the origin signal ORG, the motor will return to find C-pulse; the figure is shown as below:

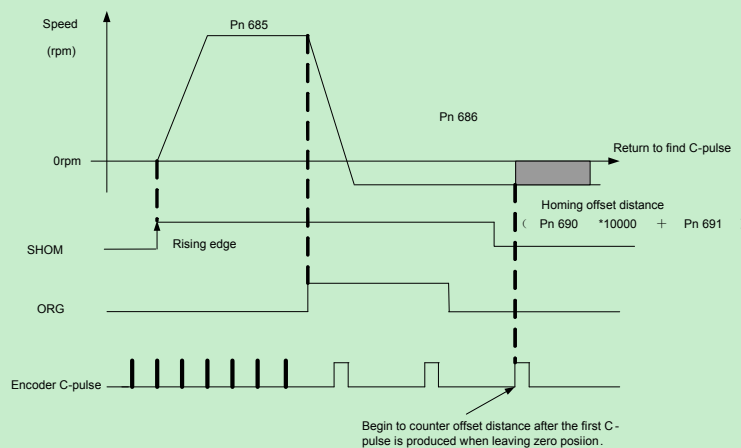

Corresponding position:

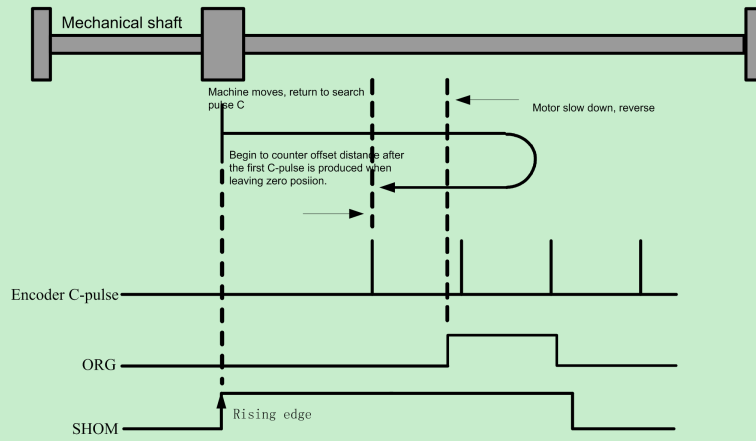

After hitting the origin signal ORG, the motor will find C-pulse directly; the figure is shown as below:

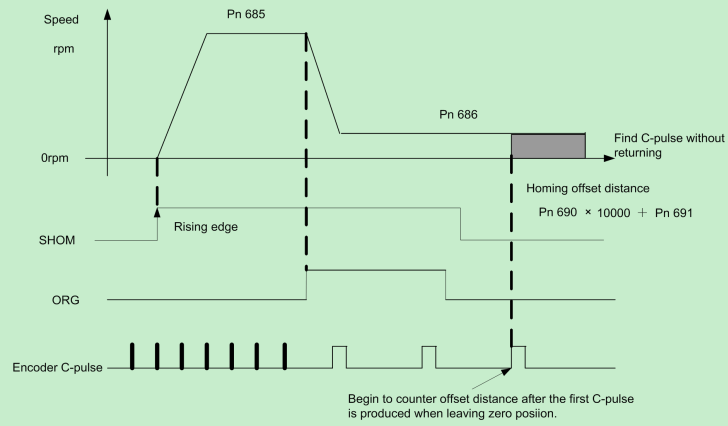

Corresponding position:

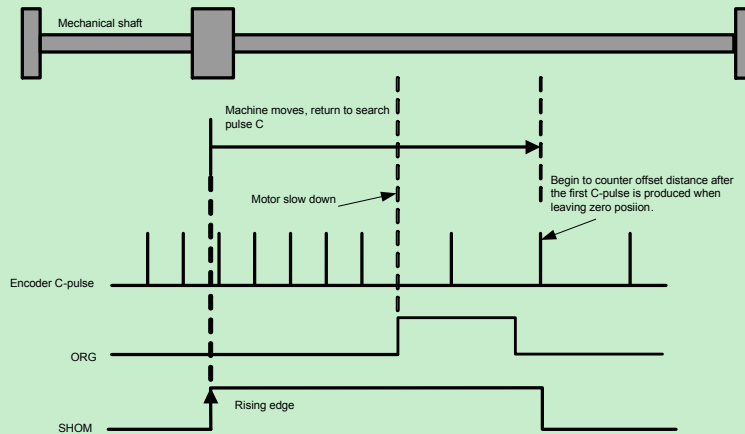

4.6 Limiting Torque

The servo drive provides internal torque limit/external torque limit for limiting output torque to protect the machine.

4.6.1 Internal Torque Limit

Maximum torque is always limited to the values set in the following parameters.

Pn401	Forward Torque Limit		Speed	Position
	Setting Range	Setting Unit	Factory Seeting	Setting Validation
	0~300	%	300	Immediately
Pn402	Reverse Torque Limit		Speed	Position
	Setting Range	Setting Unit	Factory Seeting	Setting Validation
	0~300	%	300	Immediately

- The setting unit is a percentage of rated torque.
- The maximum torque of the servomotor is used, even though the torque limit is set higher than the maximum torque of the servomotor. (as is the case with the 300% factory setting)

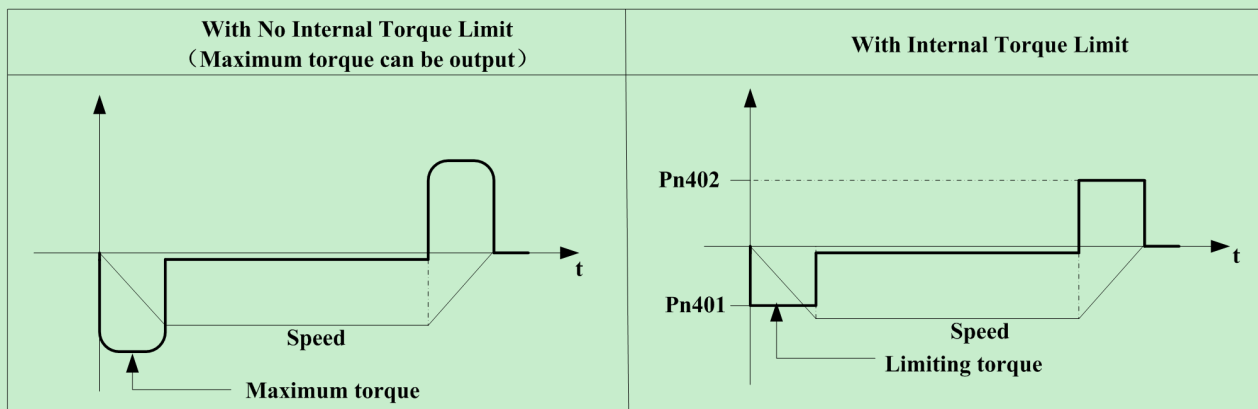

■ Note:

Too small a torque limit setting will result in insufficient torque during acceleration and deceleration.

4.6.2 External Torque Limit

This function allows the torque to be limited at specific times during machine operation, for example, during press stops and hold operations for robot workpieces.

An input signal is used to enable the torque limits previously set in parameters.

(1)Related Parameters

Pn403	Forward External Torque Limit		Speed	Position
	Setting Range	Setting Unit	Factory Setting	Setting Validation
	0~300	%	100	Immediately
Pn404	Reverse External Torque Limit		Speed	Position
	Setting Range	Setting Unit	Factory Setting	Setting Validation
	0~300	%	100	Immediately

Note: The setting unit is a percentage of rated torque (i.e., the rated torque is 100%).

(2)Input Signals

Type	Signal Name	Connector Pin Number	Setting	Meaning	Limit Value
Input	/P-CL	Pn509.0=6	ON(low level)	Forward external torque limit	Pn403
			OFF(high level)	Forward internal torque limit	Pn401
Input	/N-CL	Pn509.0=7	ON(low level)	Reverse external torque limit	Pn404
			OFF(high level)	Reverse internal torque limit	Pn402

When using this function, make sure that there are no other signals allocated to the same terminals as /P-CL and /N-CL.

(3)Changes in Output Torque during External Torque Limiting

Example: External torque limit (Pn401, Pn402) set to 300%

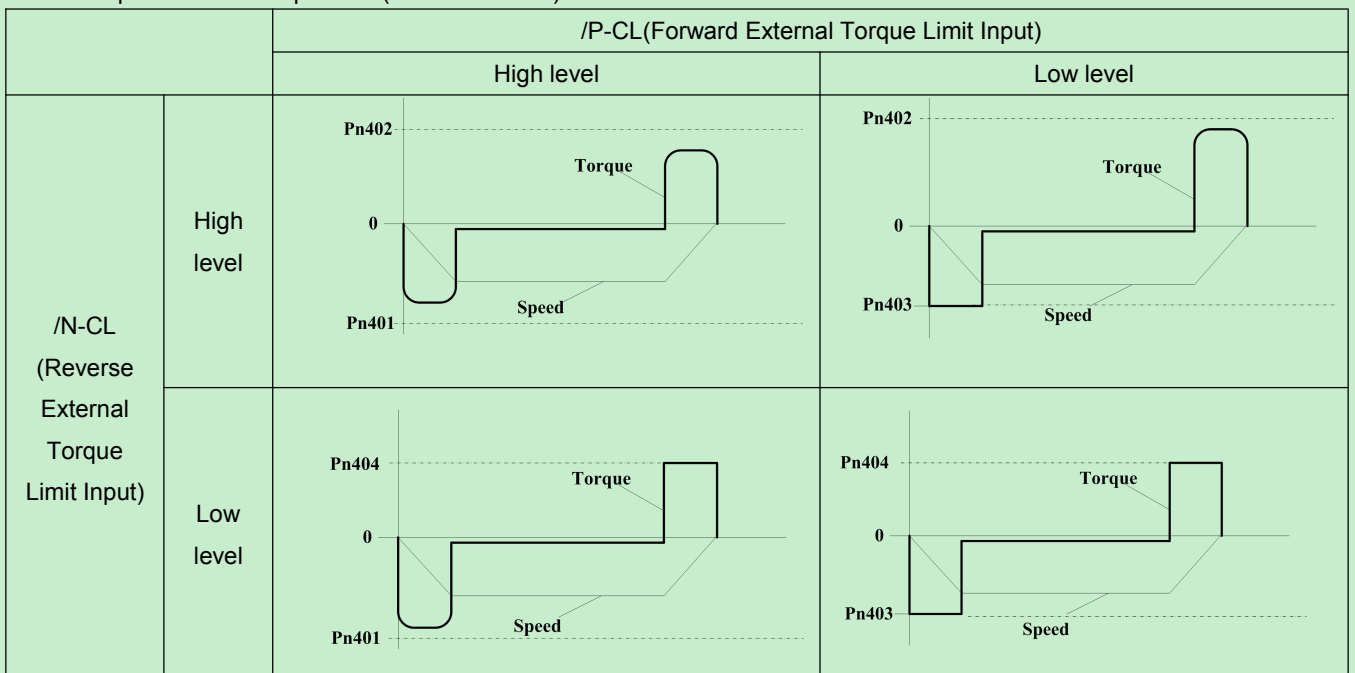

Note: Select the servomotor rotation direction by setting Pn001=b. 0 (standard setting, CCW=Forward direction).

4.7 Other Output Signals

4.7.1 Servo alarm output

The following diagram shows the right way to connect the Alarm Output.

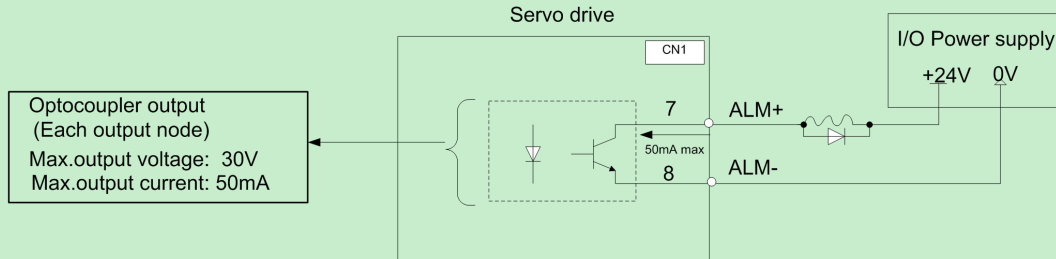

An external +24V I/O power supply is required since there is no +24V power source available inside the servo drive.

Output → ALM+CN1_A/B/C-4	Servo alarm output
Output → ALM- CN1_A/B/C-3	Servo alarm output uses grounding signal

ALM outputs a signal when the servo drive is detected in an abnormal state.

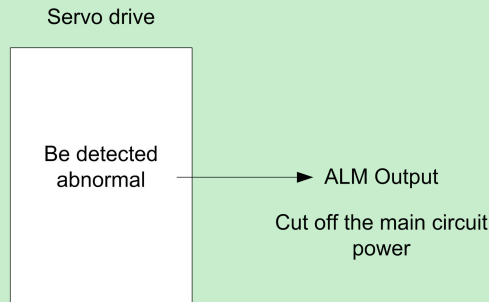

Normally, the external circuit consists of /ALM should be able to switch off the power of servo drive.

Signal	Status	Output level	Comments
ALM	ON	CN1_A/B/C-4: "L" level	Normal state
	OFF	CN1_A/B/C-4: "H" level	Alarm state

When "servo alarm(ALM)" happens, always remove alarm reasons first, and then turn the input signal "/ALM-RST" to ON position to reset alarm status.

4.7.2 Others

Pn511.0	SignalName	Connector PinNumber	Setting	Meaning
0	/COIN(/VCMP)	CN1_A/B/C-7/8	ON=L	Positioning is complete.
		CN1_A/B/C-1/2 CN1_A/B/C-5/6	OFF=H	Positioning is not complete
1	/TGON	CN1_A/B/C-7/8 CN1_A/B/C-1/2	ON=L	Servomotor is operating(Servomotor speed is above the setting in Pn503).

Pn511.0	SignalName	Connector PinNumber	Setting	Meaning
		CN1_A/B/C-5/6	OFF=H	Servomotor is not operating(Servomotor speed is below the setting in Pn503).
2	/S-RDY	CN1_A/B/C-7/8 CN1_A/B/C-1/2 CN1_A/B/C-5/6	ON=L	Servo is ready.
			OFF=H	Servo is not ready.
3	/CLT	CN1_A/B/C-7/8 CN1_A/B/C-1/2 CN1_A/B/C-5/6	ON=L	Motor output torque under limit (Internal torque reference is higher than setting value).
			OFF=H	No torque limit (Internal torque reference is lower than setting value).
4	/BK	CN1_A/B/C-7/8 CN1_A/B/C-1/2 CN1_A/B/C-5/6	ON=L	Releases the brake.
			OFF=H	Applies the brake.
5	PGC	CN1_A/B/C-7/8 CN1_A/B/C-1/2 CN1_A/B/C-5/6	ON=L	With encoder C pluse output
			OFF=H	Without encoder C pluse output
6	OT	CN1_A/B/C-7/8 CN1_A/B/C-1/2 CN1_A/B/C-5/6	ON=L	Without forward rotation Prohibited(POT) and reverse rotation prohibited(NOT)signal
			OFF=H	With forward rotation Prohibited(POT)and reverse rotation prohibited(NOT)signal
7	/RD	CN1_A/B/C-7/8 CN1_A/B/C-1/2 CN1_A/B/C-5/6	ON=L	Servo enabled motor excitation
			OFF=H	Servo disabled motor not excitation
8	/HOME	CN1_A/B/C-7/8 CN1_A/B/C-1/2 CN1_A/B/C-5/6	ON=L	Homing is enabled
			OFF=H	Homing is disabled

4.8 Online Autotuning

4.8.1 Online Autotuning

Online autotuning calculates the load moment of inertia during operation of the servo drive and sets parameters so that the servo gains are consistent with the machine rigidity.

Online autotuning may not be effective in the following cases:

- The motor high speed is lower than 100 rpm.
- The motor acceleration or deceleration is lower than 5000rpm/s.
- Load rigidity is low and mechanical vibration occurs easily or friction is high.
- The speed load moment is changed greatly.
- Mechanical gas is very large.

If the condition meets one of the above cases or the desired operation cannot be achieved by the online autotuning, set the value in Pn106 (Load inertia percentage) and perform the adjustment manually.

4.8.2 Online Autotuning Procedure



- Do not perform extreme adjustment or setting changes causing unstable servo operation. Failure to observe this warning may result in injury and damages to the machine.
- Adjust the gains slowly while confirming motor operation.

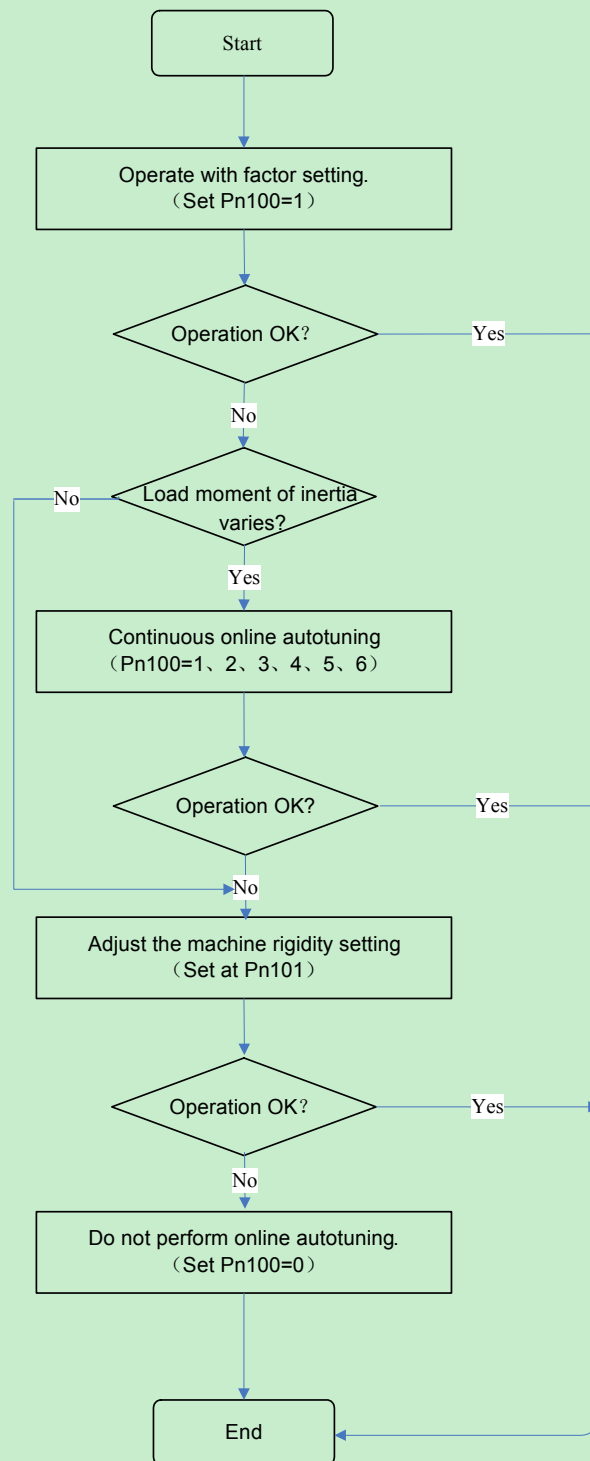

4.8.3 Setting Online Autotuning

Related parameters:

Parameter No.	Name	Unit	Setting Range	Factory Setting	Setting Invalidation
Pn100	Online autotuning setting 0:Manual gain adjustment 1,2,3=Normal mode;4,5,6=Vertical load	—	0~6	0	After restart

	1,4 = Load inertia without variation; 2,5 = Load inertia with little variation; 3,6=Load inertia with great variation				
Pn101	Machine rigidity setting	—	0~15	5	Immediately
Pn128	Speed gain acceleration relationship during online autotuning If the setting is greater, the servo gain will increase.	—	0~3	3	Immediately

4.8.4 Machine Rigidity Setting for Online Autotuning

There are 16 machine rigidity settings for online autotuning, When the machine rigidity setting is selected, the servo gains (speed loop gain, speed loop integral time constant, position loop gain) are determined automatically. The factory setting for the machine rigidity setting is 5.

Machine Rigidity Setting	Position Loop Gain 【s ⁻¹ 】 Pn104	Speed Loop Gain 【Hz】 Pn102=Pn104*(Pn128+1)	Speed Loop Integral Time Constant 【0.1ms】 Pn103
0	10	40	800
1	15	60	600
2	20	80	450
3	25	100	400
4	30	120	300
5	40	160	200
6	65	260	140
7	80	320	110
8	100	400	90
9	120	480	80
10	140	560	70
11	160	640	60
12	180	720	55
13	210	840	50
14	250	1000	40
15	300	1200	30

Chapter 5

Panel Operator

5.1 Basic Operation

5.1.1 Functions on Panel Operator

The panel operator is a built-in operator that consists of display section and keys located on the front panel of the servo drive.

Parameter setting, status display, and execution of utility function are enabled using the panel operator.

The names and functions of the keys on the panel operator are shown as follows:

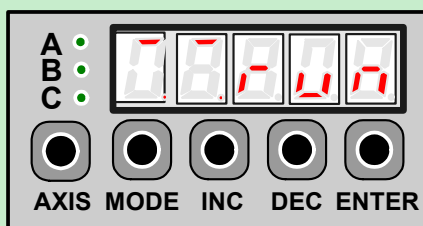

Panel Symbol	Corresponding Key Name	Function
AXIS	AXIS key	To switch the number of axis
▲	INC key	<ul style="list-style-type: none"> To display the parameter settings and setting values. To increase the setting value.
▼	DEC key	<ul style="list-style-type: none"> To decrease the setting value.
M	MODE key	<ul style="list-style-type: none"> To select a basic mode, such as the display mode, parameter setting mode, monitor mode, or utility function mode. To save the setting during parameter setting and exit.
◀	ENTER key	To display the parameter settings and setting values, and release alarm.

Note: In this manual, the Panel Symbol is represented by Corresponding Key Name for easy understanding.

5.1.2 Switch the number of Axis

Servo axes can be switched by pressing the AXIS key when the panel operator is in display mode.

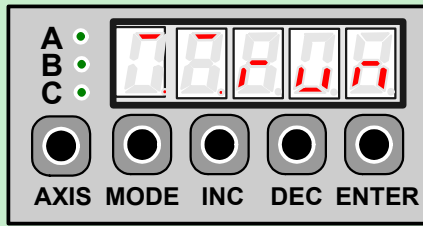

5.1.3 Basic Mode Selection

The basic modes include status display mode, parameter setting mode, monitor mode, and utility function mode. Each time the MODE key is pressed, the next mode in the sequence is selected.

Select a basic mode to display the operation status, set parameters and operation references.

The basic mode is selected in the following order.

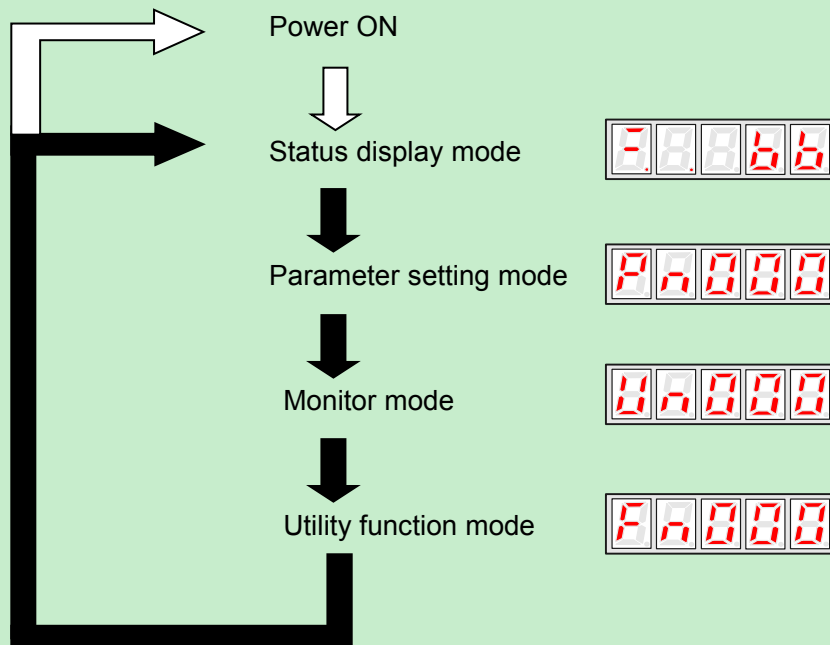

5.1.4 Status Display Mode

The status display mode displays the servo drive status as bit data and codes.

Selecting Status Display Mode

The status display mode is selected when the power supply is turned ON. If it is not displayed, select this mode by pressing MODE key.

Note that the display differs between the speed/torque control and position control types.

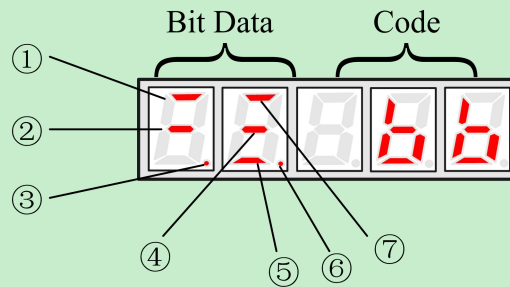

■ Bit Data Display

No.	Speed/Torque Control Mode		Position Control Mode	
	Bit Data	Description	Bit Data	Description
①	Speed Coincidence	Lit when the difference between the servomotor and reference speed is the same as or less than the preset value. Present value:Pn501(factory setting is 10rpm) Always lit in torque control mode.	Positioning Completion	Lit if error between position reference and actual servomotor position is below preset value. Present value:Pn500(10 pulse isfactory setting)
②	Base lock	Lit for base block. Not lit at servo ON.	Base block	Lit for base block. Not lit at servo ON.
③	Control power ON	Lit when servo drive control power is ON.	Control power ON	Lit when servo drive control power is ON.
④	Speed reference input	Lit if input speed reference exceeds preset value.Not lit if input speed reference is below preset value. Preset value: Pn503(factory setting is 20 rpm)	Reference pulse input	Lit if reference pulse is input. Not lit if no reference pulse is input.
⑤	Torque reference input	Lit if input torque reference exceeds preset value. Not lit if input torque reference is below preset value. Preset value: 10% of rated torque	Error counter clear signal input	Lit when error counter clear signal is input. Not lit when error counter clear signal is not input.
⑥	Power ready	Lit when main circuit power supply is ON and normal. Not lit when main circuit power supply is OFF.	Power ready	Lit when main circuit power supply is ON and normal. Not lit when main circuit power supply is OFF.
⑦	Rotation detection /TGON	Lit if servomotor speed exceeds preset value.Not lit if servomotor speed is below preset value. Preset value:Pn503(factory setting is 20 rpm)	Rotation detection /TGON	Lit if servomotor speed exceeds preset value.Not lit if servomotor speed is below preset value. Preset value:Pn503(factory setting is 20 rpm)

■ Codes Display

Code	Meaning
	Baseblock Servo OFF(servomotor power OFF)
	Run Servo ON (servomotor power ON)
	Forward Run Prohibited CN1_A/B/C_12 (P-OT) is OFF.
	Reverse Run Prohibited CN1_A/B/C_13 (N-OT) is OFF.
	Alarm Status Displays the alarm number.

Press ENTER key to clear the present servo alarm.

5.1.5 Operation in Parameter Setting Mode

The servo drive offers a large number of functions, which can be selected or adjusted by the parameter settings. Refer to **A.1 Parameter List** for details.

■ Parameter Setting Procedures

The parameter settings can be used for changing parameter data. Before changing the data, check the permitted range of the parameter.

The example below shows how to change parameter Pn102 from “100” to “85”.

1. Press MODE key to select the parameter setting mode.



2. Press INC key or DEC key to select parameter number.



3. Press ENTER key to display the current data of Pn102.



4. Press the INC or DEC key to change the data to the desired number 00085. Hold the key to accelerate the changing of value. When the maximum value or minimum value is reached, pressing INC or DEC key respectively, will have no effect.



5. Press the ENTER or MODE key once to return to the display of Pn102.



5.1.6 Operation in Monitor Mode

The monitor mode allows the reference values input into the servo drive, I/O signal status, and servo drive internal status to be monitored.

■ Using the Monitor Mode

The example below shows how to display the value (1500) stored in Un001.

1. Press MODE key to select the monitor mode.



2. Press the INC or DEC key to select the monitor number to display.



3. Press the ENTER key to display the data for the monitor number selected at step 2.



4. Press the ENTER key once more to return to the monitor number display.



■ List of Monitor Modes

Contents of Monitor Mode Display

Monitor Number	Monitor Display	
Un000	Actual servomotor speed Unit: rpm	
Un001	Reserved	
Un002	Reserved	
Un003	Internal torque reference Unit:% (with respect to rated torque)	
Un004	Number of encoder rotation angle pulses	
Un005	Input signal monitor	→
Un006	Encoder signal monitor	→
Un007	Output signal monitor	→
Un008	Frequency given by pulse Unit:1kHz	
Un009	Number of servomotor rotation pulses	
Un010	Pulse rate of servomotor rotated (x10 ⁴)	
Un011	Error pulse counter lower 16 digit	
Un012	Error pulse counter higher 16 digit	
Un013	Number of pulses given	
Un014	Number of pulses given (x10000)	
Un015	Load inertia percentage	
Un016	Servomotor overload ratio	
Un017	Bus voltage Unit:V	

Internal status bit display

7 6 5 4 3 2 1 0



Contents of Bit Display:

MonitorNumber	Display LED Number	Content
Un005	0	/SON(CN1_A/B/C-10)
	1	/P-CON(CN1_A/B/C-11)
	2	P-OT(CN1_A/B/C-12)
	3	N-OT(CN1_A/B/C-13)
	4	/ALM-RST(CN1_A/B/C-14)
	5	/CLR (CN1_A/B/C -15)
	6	/PCL(CN1_A/B/C-16)
	7	/NCL(CN1_A/B/C-17)

Monitor Number	Display LED Number	Content
Un006	0	(Not used)
	1	(Not used)
	2	(Not used)
	3	(Not used)
	4	Phase-C
	5	Phase-B
	6	Phase-A
	7	(Not used)

Monitor Number	Display LED Number	Content
Un007	0	ALM (CN1_A/B/C-3/4)
	1	/COIN(CN1_A/B/C-7/8)
	2	/TGON(CN1_A/B/C-1/2)
	3	/S-RDY(CN1_A/B/C-5/6)

5.2 Operation in Utility Function Mode

In utility function mode, the panel operator can be used to run and adjust the servo drive and servomotor.

The following table shows the parameters in the utility function mode.

Parameter No.	Function
Fn000	Alarm traceback data display
Fn001	Parameter setting initialization
Fn002	JOG mode operation
Fn003	Reserved
Fn004	Reserved
Fn005	Automatic adjustment of servomotor current detection
Fn006	Manual adjustment of servomotor current detection
Fn007	Software version display
Fn008	Position teaching
Fn009	Static inertia detection
Fn010	Reserved
Fn011	Reserved
Fn012	Reserved
Fn013	Parameters copy
Fn014	Reserved

5.2.1 Alarm Traceback Data Display

The alarm traceback display can display up to 10 previously occurred alarms. The alarm is displayed on Fn000, which is stored in the alarm traceback data.

Follow the procedures below to confirm alarms which have been generated.

1. Press the MODE key to select the utility function mode.
2. Press the INC or DEC key to select the function number of alarm traceback data display.



3. Press the ENTER key once, the latest alarm data is displayed.

Alarm Sequence Number Alarm Code

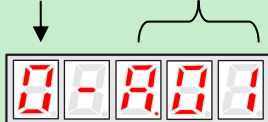

4. Press the INC or DEC key to display other recent alarms that have occurred.

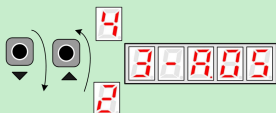

5. Press the ENTER key, the display will return to Fn000.



Note: Hold the ENTER key for one second with alarm code displaying, all the alarm traceback datas will be cleared.



5.2.2 Parameter Settings Initialization

Follow the procedures below to execute the parameter settings initialization.

1. Press the MODE key to select the utility function mode.
2. Press the INC or DEC key to select the function number of parameter settings initialization.



3. Press the ENTER key to enter into parameter settings mode.

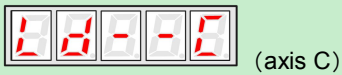
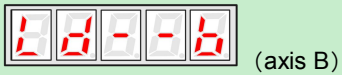

4. Hold the ENTER key for one second, the parameters will be initialized.

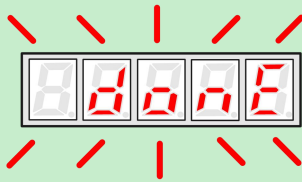

5. Release the ENTER key to return to the utility function mode display Fn001.



Note:

Press the ENTER key during servo ON does not initialize the parameter settings.
Initialize the parameter settings with the servo OFF.

5.2.3 Operation in JOG Mode

Follow the procedures below to operate the servomotor in JOG mode.

1. Press the MODE key to select the utility function mode.
2. Press the INC or DEC key to select the function number of JOG mode operation.



3. Press the ENTER key to enter into JOG operation mode.



4. Press the MODE key to enter into servo ON (servomotor power ON) status.



5. Press the MODE key to switch between the servo ON and servo OFF status. The servo drive must be in servo ON status when the servomotor is running.
6. Press the INC or DEC key to rotate the servomotor.

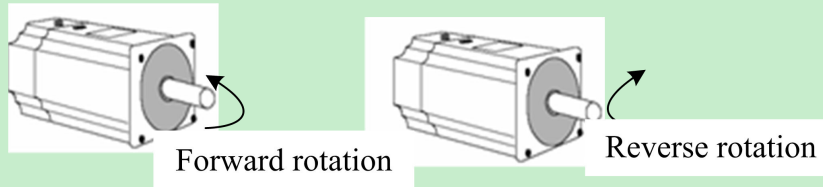

7. Press the ENTER key to return to utility function mode display Fn002. Now the servo is OFF (servomotor power OFF).



5.2.4 Offset-adjustment of Servomotor Current Detection Signal

Automatic servomotor current detection offset adjustment is performed at ESTUN before shipping. Basically, the user does not need to perform this adjustment.

Perform this adjustment only if highly accurate adjustment is required for reducing torque ripple caused by current offset. This section describes the automatic and manual servomotor current detection offset adjustment.

Note:

- Offset-adjustment of the servomotor current detection signal is possible only while power is supplied to the main circuit power supply and with the servo is the OFF state.
- Execute the automatic offset adjustment if the torque ripple is too big when compared with that of other servo drives.
- If this function, particularly manual adjustment, is executed carelessly, it may worsen the characteristics.

■ Automatic Offset-adjustment of Servomotor Current Detection Signal

Adjust the servomotor current detection signal automatically in the following procedure:

1. Press the MODE key to select the utility function mode.
2. Press the INC or DEC key to select the utility function number Fn005.



3. Press the ENTER key to enter into the automatic adjustment of the servomotor current detection signal mode.



4. Press the MODE key, the display will blink for one second. The offset will be automatically adjusted.

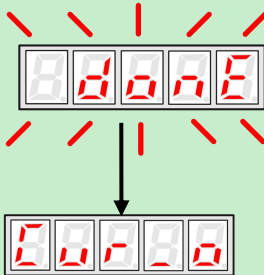

5. Press the ENTER key to return to the utility function mode display Fn005.



Thus, the automatic offset-adjustment of the servomotor current detection signal is complete.

■ Manual Offset-adjustment of Servomotor Current Detection Signal

Adjust the servomotor current detection signal manually in the following procedure.

1. Press the MODE key to select the utility function mode.
2. Press the INC or DEC key to select the utility function number Fn006.



3. Press the ENTER key to enter into the manual adjustment of the servomotor current detection signal.



4. Press the MODE key to switch between the phase U(o _ CuA) and phase V(1_ Cub) servomotor current detection offset adjustment.



5. Hold the ENTER key for one second to display the phase V offset amount.

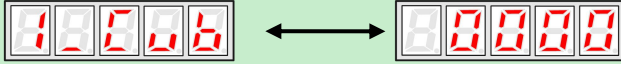

6. Press the INC or DEC key to adjust the offset.

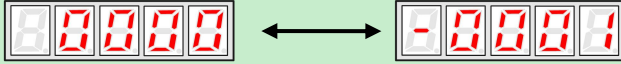

7. Press the ENTER key for one second to return to the display in step 3 or 4.

8. Press the ENTER key to return to the utility function mode display Fn006.



Thus, the manual offset-adjustment of the servomotor current detection signal is completed.

Note:

The adjusting range of the servomotor current detection offset is -100 to +100.

5.2.5 Software Version Display

Select Fn007 in utility function mode to check the current software version of the drive.

1. Press the MODE key to select the utility function mode.
2. Press the INC or DEC key to select the utility function number Fn007.



3. Press the ENTER key to display the DSP software version (the highest bit displays d or E or F or 0).



4. Press the MODE key to display the FGPA/CPLD software version (the highest bit displays P).

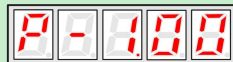

5. Press the MODE key to return to DSP software version display.
6. Press the ENTER key to return to the utility function mode display Fn007.

5.2.6 Position Teaching Function

Perform the position teaching function in the following procedure.

1. Press the MODE key to select the utility function mode.
2. Press the INC or DEC key to select the utility function number Fn008.



3. Press the ENTER key, the display will be shown as below.



4. Press the ENTER key, the display will be shown as below.

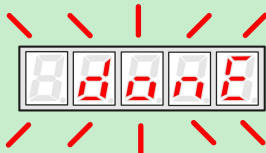

5. Release the ENTER key to complete position teaching function.

5.2.7 Static Inertia Detection

1. Press the MODE key to select the utility function mode.
2. Press the INC or DEC key to select the utility function number Fn009.



3. Press the ENTER key, the display will be shown as below.



4. Press the MODE key to rotate the servomotor, and the servomotor dynamic speed will be displayed.
5. The unit of the servomotor and load total inertia displayed when servomotor stops is kg.cm²

Thus, the static inertia detection is complete.

Note: Make sure that the servomotor completes at least 6 full revolutions in the CCW direction before detection.

5.2.8 Parameters Copy

1. Press the MODE key to select the utility function mode.
2. Press the INC or DEC key to select the utility function number Fn013.



3. Press the ENTER key, the display will be shown as below.



(A-axis, Parameters are copied from A to B)



(B-axis, Parameters are copied from B to A)

.....

4. Press the ENTER key, the display will be shown as below.

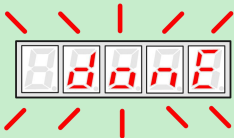

5. Release the ENTER key to complete position teaching function.

Chapter 6

MODBUS Communication

6.1 RS-485 Communication Wiring

ETS series servo drives provide the MODBUS communication function with RS-485 interface, which can be used to easily set parameters or to perform monitoring operations and so on.

The definitions of the servo drive communication connector terminals(CN3、CN4) are as follows.

Terminal No.	Name	Function
1	—	Reserved
2	—	Reserved
3	485+	RS-485 communication terminal
4	ISO_GND	Isolated ground
5	ISO_GND	
6	485-	RS-485 communication terminal
7	CANH	CAN communication terminal
8	CANL	CAN communication terminal

Note:

1. The length of the cable should be less than 100 meters and in a environment with minimal electrical disturbance/interference. However, if the transmission speed is above 9600bps, please use the communication cable within 15 meters to ensure transmission accuracy..
2. A maximum of 31 servo drives can be connected when RS485 is used. Terminating resistances are used at both ends of the 485 network. If more devices are wanted to connect, use the repeaters to expand.
3. CN3 of servo drive is always used as communication cable input terminal, and CN4 is always used as communication cable output terminal(If still need to connect slave stations, the communication cable is connected from CN4 terminal to the next slave station; if need not, add balance resistor in CN4 terminal.).It is prohibited to connect CN3 of any two servo drives directly when multiple ETS series servo drives are connected.

Example:

When a RS-485 network is composed of a PLC and three servo drives (A, B, and C), the cable wiring is shown as follows:
 PLC→CN3 of A, CN4 of A→CN3 of B, CN4 of B→CN3 of C, CN4 of C→120Ω terminating resistance.

6.2 MODBUS Communication Related Parameters

Parameter No.	Description	Setting Validation	Control Mode	Meaning
Pn700	Hex	After restart	ALL	Pn700.0 MODBUS baud rate [0] 4800bps

				<p>[1] 9600bps [2] 19200bps [3] 38400bps [4] 57600bps [5] 115200bps</p> <p>Pn700.1 Communication protocol selection</p> <p>[0] 7, N, 2 (MODBUS,ASCII) [1] 7, E, 1 (MODBUS,ASCII) [2] 7, O, 1 (MODBUS,ASCII) [3] 8, N, 2 (MODBUS,ASCII) [4] 8, E, 1 (MODBUS,ASCII) [5] 8, O, 1 (MODBUS,ASCII) [6] 8, N, 2 (MODBUS,RTU) [7] 8, E, 1 (MODBUS,RTU) [8] 8, O, 1 (MODBUS,RTU)</p> <p>Pn700.2 Communication protocol selection</p> <p>[0] SCI communication with no protocol [1] MODBUS SCI communication</p> <p>Pn700.3 Reserved</p>
Pn701	Axis address	After restart	ALL	Axis address of MODBUS protocol communication

6.3 MODBUS Communication Protocol

There are two modes for MODBUS communication: ASCII (American Standard Code for information interchange) mode and RTU (Remote Terminal Unit) mode.

The next section describes the two communication modes.

6.3.1 Code Meaning

ASCII Mode:

Every 8-bit data is consisted by two ASCII characters. For example: One 1-byte data 64 H (Hexadecimal expression) is expressed as ASCII code '64', which contains '6' as ASCII code 36_H and '4' as ASCII code 34_H.

ASCII code for number 0 to 9、character A to F are as follows:

Character	'0'	'1'	'2'	'3'	'4'	'5'	'6'	'7'
ASCII Code	30 _H	31 _H	32 _H	33 _H	34 _H	35 _H	36 _H	37 _H
Character	'8'	'9'	'A'	'B'	'C'	'D'	'E'	'F'
ASCII Code	38 _H	39 _H	41 _H	42 _H	43 _H	44 _H	45 _H	46 _H

RTU Mode:

Every 8-bit data is consisted by two 4-bit hexadecimal data, that is to say, a normal hexadecimal data. For example: decimal data 100 can be expressed as 64_H by 1-byte RTU data.

Data Structure:

10-bit character form (7-bit data)

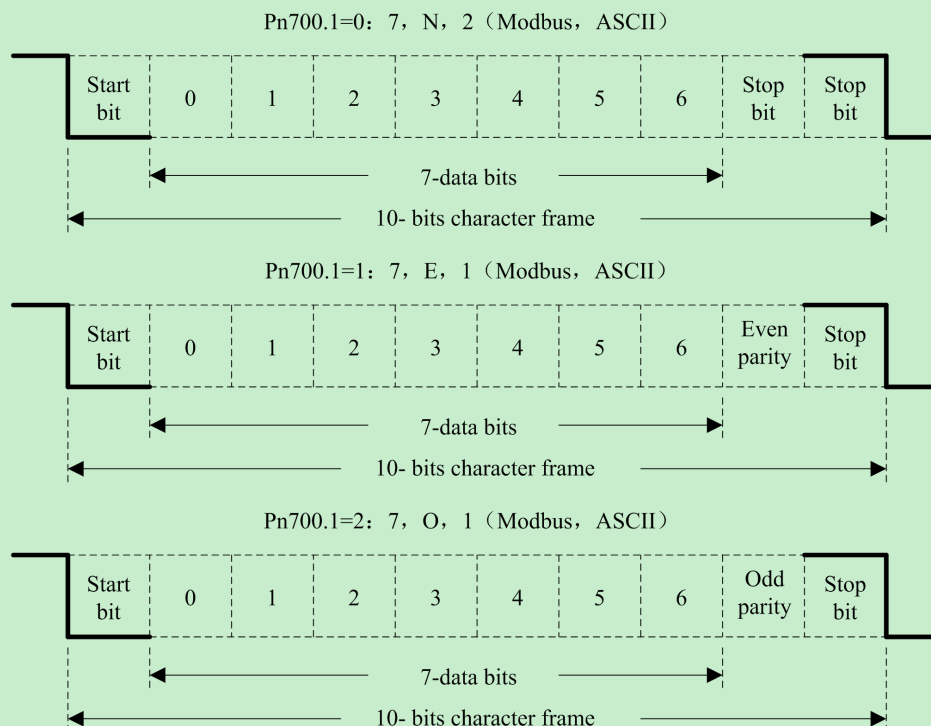

11-bit character form (8-bit data)

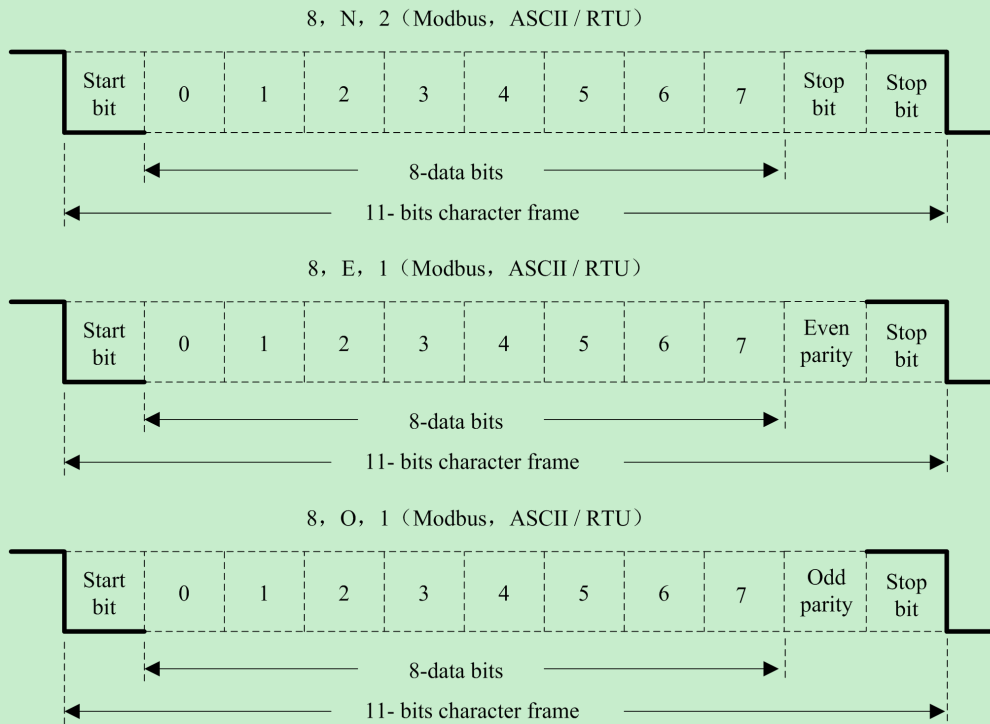

Communication protocol structure:

Data format of communication protocol:

ASCII Mode:

STX	Start character: ' => (3A _H)
ADR	Communication address => 1-byte contains two ASCII codes
CMD	Reference code => 1-byte contains two ASCII codes
DATA(n-1)	Data content => n-word=2n-byte contain 4nASCII codes, n ≤ 12
.....	
DATA(0)	
LRC	Checking code => 1-byte contains two ASCII codes
End 1	End code 1 => (0D _H) (CR)
End 0	End code 0 => (0A _H) (LF)

RTU Mode:

STX	Sleep interval of at least 4 bytes transmission time.
ADR	Communication address => 1-byte
CMD	Reference code => 1-byte
DATA(n-1)	Data content => n-word=2n-byte, n ≤ 12
.....	
DATA(0)	
CRC	CRC checking code => 1-byte
End 1	Sleep interval of at least 4 bytes transmission time.

Communication protocol data format instructions are as follows:

STX (communication start)

ASCII mode: ':' character

RTU mode: Sleep interval of at least 4 bytes transmission time (automatically changed according to different

communication speed).

ADR (communication address)

Valid communication address: 1 to 254

For example: communicate with the servo drive which address is 32 (20 in hex):

ASCII mode: ADR='2', '0'=>'2'=32_H, '0'=30_H

RTU mode: ADR=20_H

CMD (command reference) and DATA (data)

Data structure is determined by command code. Regular command code is shown as follows:

Command code: 03_H, read N words(word), N ≦ 20.

For example: read 2 words starting from 0200_H from the servo drive which address is 01_H.

ASCII mode:

Reference information:

STX	“:”
ADR	'0'
	'1'
CMD	'0'
	'3'
Data start address	'0'
	'2'
	'0'
	'0'
Data number (count as word)	'0'
	'0'
	'0'
	'2'
LRC checking	'F'
	'8'
End 1	(0D _H)(CR)
End 0	(0A _H)(LF)

Response information:

STX	“:”
ADR	'0'
	'1'
CMD	'0'
	'3'
Data number (count as byte)	'0'
	'4'
Content of data start address 0200 _H	'0'
	'0'
	'0'
	'0'
Content of second data address 0201 _H	'0'
	'0'
	'0'
LRC checking	'F'
	'8'
End 1	(0D _H)(CR)
End 0	(0A _H)(LF)

RTU mode:

Reference information:

ADR	01 _H
CMD	03 _H
Data start address	02 _H (high-bit)
	00 _H (low-bit)
Data number (count as word)	00 _H
	02 _H
CRC checking	C5 _H (low-bit)
CRC checking	B3 _H (high-bit)

Response information:

ADR	01 _H
CMD	03 _H
Data number (count as byte)	04 _H
	00 _H (high-bit)
Content of data start address 0200 _H	00 _H (low-bit)
	00 _H (high-bit)
Content of second data address 0201 _H	00 _H (low-bit)
	00 _H (high-bit)
CRC checking	FA _H (low-bit)
CRC checking	33 _H (high-bit)

Reference code: 06_H, write in one word

For example: write 1 (0001_H) into 01_H servo address 0200_H.

ASCII mode:

Reference information:

STX	“:”
ADR	‘0’
	‘1’
CMD	‘0’
	‘6’
Data start address	‘0’
	‘2’
	‘0’
	‘0’
Data content	‘0’
	‘0’
	‘0’
	‘1’
LRC checking	‘F’
	‘6’
End 1	(0D _H)(CR)
End 0	(0A _H)(LF)

Response information:

STX	“:”
ADR	‘0’
	‘1’
CMD	‘0’
	‘6’
Data start address	‘0’
	‘2’
	‘0’
	‘0’
Content of data start address 0200 _H	‘0’
	‘0’
	‘0’
	‘1’
LRC checking	‘F’
	‘6’
End 1	(0D _H)(CR)
End 0	(0A _H)(LF)

RTU mode:

Reference information:

ADR	01 _H
CMD	06 _H
Data start address	02 _H (high-bit)
	00 _H (low-bit)
Data content	00 _H (high-bit)
	01 _H (low-bit)
CRC checking	49 _H (low-bit)
CRC checking	B2 _H (high-bit)

Response information:

ADR	01 _H
CMD	06 _H
Data start address	02 _H (high-bit)
	00 _H (low-bit)
Data content	00 _H (high-bit)
	01 _H (low-bit)
CRC checking	49 _H (low-bit)
CRC checking	B2 _H (high-bit)

LRC (ASCII mode) and CRC (RTU mode) error detection value calculation:

LRC calculation in ASCII mode:

ASCII mode uses LRC (LongitudinalRedundancy Check) error detection value. The exceeded parts (e.g. the total value is 128_H of hex, then take 28_H only) is taken off by the unit of 256 in the total value from ADR to the last information, then calculate and compensate, the final result is LRC error detection value.

For example: read 1 word from 01_H servo address 0201_H

STX	‘:’
ADR	‘0’
	‘1’
CMD	‘0’
	‘3’
Data start address	‘0’
	‘2’
	‘0’
	‘1’
Data number (count as word)	‘0’
	‘0’
	‘0’
	‘1’
LRC checking	‘F’
	‘8’
End 1	(0D _H)(CR)
End 0	(0A _H)(LF)

Add from ADR data to the last data.

$$01_H + 03_H + 02_H + 01_H + 00_H + 01_H = 08_H$$

The compensate value is F8_H when 2 is used to compensate 08_H, so LRC is “F”, “8”.

CRC calculation of RTU mode:

RTU mode uses CRC (Cyclical Redundancy Check) error detection value.

The process of CRC error detection value calculation is shown as follows:

Step 1: Load in a 16-bit register of FFFF_H, named “CRC” register.

Step 2: Run XOR calculation between the first bit (bit 0) of instruction information and 16-bit CRC register’s low bit (LSB), and the result is saved to CRC register.

Step 3: Check the lowest bit (LSB) of CRC register, if it is 0, CRC register moves one bit to right; if it is 1, CRC register moves one bit to right, then run XOR calculation with A001_H;

Step 4: Go to step 5 till the third step has been executed for 8 times, otherwise return to step 3.

Step 5: Repeat the steps from 2 to 4 for the next bit of instruction information, the comment of CRC register is the CRC error detection value while all the bits have been executed by the same way.

Note: After calculating out the CRC error detection value, the CRC low bit should be filled first in instruction information, and then fill the high bit of CRC.

Please refer to the following example:

Read 2 words from the 0101_H address of 01_H servo. The final CRC register content calculated from ADR to the last bit of data is 3794_H, and then the instruction information is shown as follows,

Please be sure that 94_H is transmitted before 37_H.

ADR	01 _H
CMD	03 _H
Data start address	01 _H (high-bit)
	01 _H (low-bit)
Data number (count as word)	00 _H (high-bit)
	02 _H (low-bit)
CRC checking	94 _H (low-bit)
CRC checking	37 _H (high-bit)

End1、End0 (Communication is complete.)

ASCII mode:

Communication is ended with (0DH) - [carriage return] and (0AH) - [new line].

RTU mode:

When the time exceeds the sleep interval by at least 4 bytes transmission time while in the current communication speed, it means the communication is finished.

Example:

The following example uses C language to generate CRC value. The function needs two parameters.

```
unsigned char * data;
```

```
unsigned char length;
```

The function will return unsigned integer type CRC value.

```
unsigned int crc_chk(unsigned char * data,unsigned char length){  
    int i,j;  
    unsigned int crc_reg=0xFFFF;  
    While(length- -){  
        crc_reg ^=*data++;  
        for(j=0;j<8;j++){  
            If(crc_reg & 0x01){  
                crc_reg=( crc_reg >>1)^0xA001;  
            }else{  
                crc_reg=crc_reg >>1;  
            }  
        }  
    }  
    return crc_reg;  
}
```

6.3.2 Communication Error Disposal

Problems that occur during communication are a result of the following:

- Data address is incorrect while reading/writing parameters.
- The data is not within the parameter setting range while writing.
- Data transmission fault or checking code fault when communication is disturbed.

When the first and second communication faults occur, the servo drive is running normally, and will feed back an error frame.

When the third communication fault occurs, transmission data will be recognized as invalid to give up, and no error frame is returned.

The format of error frame:

Host controller data frame:

start	Slave station address	Command	Data address,content	Checking
		command		

Servo drive feeds back error frame:

start	Slave station address	Response code	Error code	Checking
		command+80 _H		

Error frame responses code=command+80_H

Error code=00_H: Normal communication

=01_H: Servo drive cannot identify the required functions

=02_H: The required data address does not exist in the servo drive

=03_H: The required data in servo drive is not allowed. (Beyond the maximum or minimum value of the parameter)

=04_H: Servo drive starts to perform the requirement, but cannot achieve it.

For example: Servo drive axis number is 03_H, write data 06_H into parameter Pn100 is not allowed, because the range of parameter Pn100 is 0~6. The servo drive will feedback an error frame, the error code is 03_H (Beyond the parameter's maximum value or minimum value).

Host controller data frame:

start	Slave station address	Command	Data address,content	Checking
	03 _H	06 _H	0002 _H 0006 _H	

Servo drive feedback error frame:

start	Slave station address	Response code	Error code	Checking
	03 _H	86 _H	03 _H	

Besides, if the data frame sent from host controller slave station address is 00_H, it determines the data to be broadcast data. The servo drives will not feed back any frames.

6.3.3 Data Communication Address of Servo State

The communication parameter addresses are shown in the following table:

Communication data address(Hex)			Meaning	Description	Operation
Axis A	Axis B	Axis B			
0000~0348	2000~2348	4000~4348	Parameter area	Corresponding parameters in parameter list	Read/write
07F1~07FA	27F1~27FA	47F1~47FA	Alarm information memory area	Ten alarms historical record	Read only
07FD	27FD	47FD	Iu zero offset		Read only
07FE	27FE	47FE	Iv zero offset		Read only
0806~0814	2806~2814	4806~4814	Monitor data (corresponding with displayed data)		
0806	2806	4806	Speed feedback	Unit:rpm	Read only
0809	2809	4809	Internal torque reference percentage	Relative rated torque	Read only
080A	280A	480A	Number of encoder rotation pulses		Read only
080B	280B	480B	Input signal state		Read only
080C	280C	480C	Encoder signal state		Read only
080D	280D	480D	Output signal state		Read only
080E	280E	480E	Pulse setting		Read only
080F	280F	480F	Low bits of present location	Unit:1 reference pulse	Read only
0810	2810	4810	High bits of present location	Unit:10000 reference pulses	Read only
0811	2811	4811	Error pulse counter low 16 bits		Read only
0812	2812	4812	Error pulse counter high 16 bits		Read only
0813	2813	4813	Setting pulse counter low bits	Unit:1 reference pulse	Read only
0814	2814	4814	Setting pulse counter high bits	Unit:10000 reference pulses	Read only
0815	2815	4815	Load inertia percentage	%	Read only
0816	2816	4816	Servomotor overloading proportion	%	Read only
0817	2817	4817	Current alarm		Read only
0900	2900	4900	MODBUS communication IO signal	Donot save when power off.	Read/write
090E			DSP version	Version is expressed by digit.	Read only
090F			CPLD version	Version is expressed by digit.	Read only
1021	3021	5021	Clear historical alarms	01:Clear	Write only
1022	3022	5022	Clear current alarms	01:Clear	Write only

1023	3023	5023	JOG servo enabled	01:Enable 00:Disable	Write only
1024	3024	5024	JOG forward rotation	01:Forward rotation 00:Stop	Write only
1025	3025	5025	JOG reverse rotation	01:Reverse rotation 00:Stop	Write only

Note:

1. Parameter area (communication address 0000~4369_H)

Parameter address is relevant to the parameters in the parameter list.

For example, axis A parameter Pn000 is relevant to communication address 0000_H; parameter Pn102 is relevant to communication address 0066_H.

2. Alarm information storage area (07F1~47FA_H)

Historical alarm number	Description	Communication address
0	Historical alarm 1 (the latest alarm)	07F1 _H
1 ~ 8	Historical alarm 2 ~ 9	07F2 _H ~ 07F9 _H
9	Historical alarm 10 (the furthest alarm)	07FA _H

3. Monitor data area (0806~0816_H)

The monitor data is corresponding to servo drive panel displays Un000~Un016.

For example: the corresponding data of communication address 0807_H (speed setting) is FB16_H.

Therefore, the speed setting is -1258r/m.

4. MODBUS communication IO signal

Use communication to control digital IO signal. This data will not be saved after power off.

It is operated with Pn512 as the communication input IO signal. That is to say, when the parameters setting in Pn512 enable the IO bit, the IO can be controlled by communication.

5. Software version (090F_H)

Use digit to represent servo drive software version. For example, if the read out data is 0100_H, it means the software version is t-1.00.

Chapter 7

Specifications and Characters

7.1 Servo drive Specifications and Models

Servo Drive Model			ETS-1010APC-CAN / ETS-101010APC / ETS-101010APC-CAN					
Applicable Servomotor Model			EMJ-02APA	EMJ-04APB	EMJ-08APB	EMJ-10APB	EMG-10APA	EML-10APA
Input Power Supply	Main Circuit		Three-phase 200~230VAC +10% -15% (50/60Hz)					
	Control Circuit		Single-phase 200~230VAC +10%~-15% (50/60Hz)					
Control Method			SVPWM					
Feedback			Incremental Wire-saving type:2500 P/R					
Operating Conditions			Ambient/Storage Temperature	0~55°C/-20~85°C				
			Ambient/Storage Humidity	90% RH (with no condensation)				
			Vibration/Shock Resistance	Vibration Resistance: 4.9m/s ² , Impact Resistance: 19.6m/s ²				
Configuration			Base-mounted					
Speed Control	Speed Selection	Rotation Direction Selection	With /P-CON signal					
		Speed	Speed 1 to 7					
	Function	Soft Start Setting	0~10s (Can be set individually for acceleration and deceleration.)					
Position Control	Pulse Reference	Type	Sign + pulse train;CCW + CW pulse train; 90°phase difference 2-phase (phase A + phase B)					
		Form	Non-insulated linde driver (about + 5V), open collector					
		Frequency	×1 multiplier: 4Mpps ×2 multiplier: 2Mpps ×4 multiplier: 1Mpps Open collector: 200Kpps Frequency will begin to decline when the duty ratio error occurs..					
	Position Reference Setting	Position Setting	16 position nodes can be set.					
I/O Signals	Encoder Dividing Pulses Output		Phase-A, phase-B, phase-C, line driver output Number of dividing pulses: (1~2500) /2500					
	Sequence Input	Number of channels	3×8channels					

	Function	Signal allocations and positive/negative logic modifications: Servo ON (/S-ON), P control (/P-CON), alarm reset (/ALM-RST), position error clear (CLR), forward run prohibited (P-OT), reverse run prohibited (N-OT), forward current limit (/P-CL), reverse current limit (/N-CL) and so on.
	Sequence Output	Number of channels 3×4channels
	Function	Signal allocations and positive/negative logic modifications: Positioning completion(/COIN), speed coincidence(/V-CMP),servomotorrotation detection(/TGON), servo ready(/S-RDY),torque limit output(/CLT),brake interlock output (/BK), encoder C pulse(/PGC), Over travel/OT) and so on..
Internal Functions	Dynamic Brake	Each axis with dynamic brake function, which operated at main power OFF, servo alarm, servo OFF or overtravel.
	Protection Functions	Overcurrent, overvoltage,low voltage, overload,regeneration error,overspeed,etc.
	Utility Function	Alarm trace back,JOG operation,load inertia detection, etc.
	Communication Function	RS-485 communication port,MODBUS protocol,CAN communication port,CANopen protocol;
	Display Function	CHARGE×1, power ×1,Axis LED ×3, 7-segment LEDS ×5, pushbutton×5

7.2 Servo drive Dimensional Drawings

Unit: mm

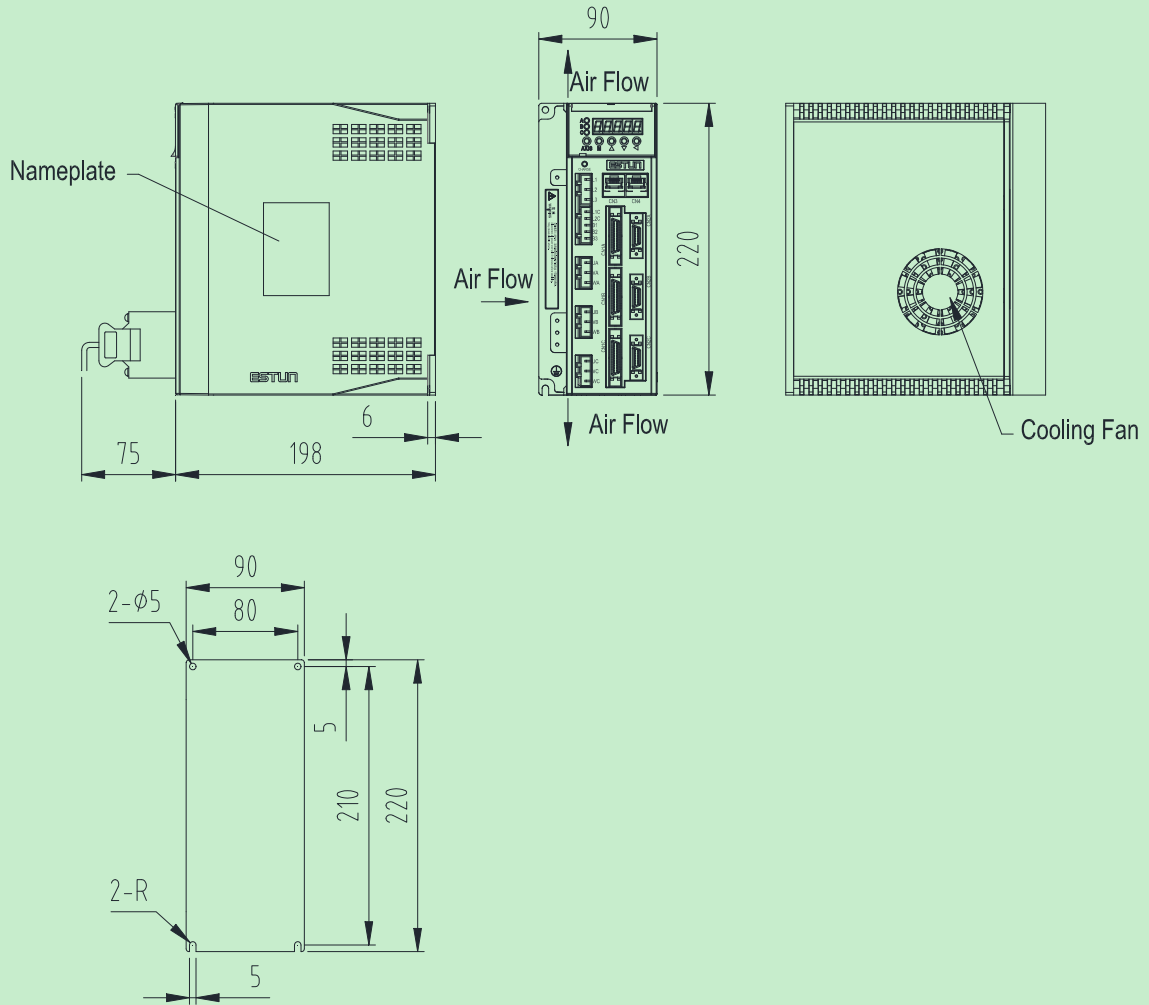

Appendix A

Parameter

A.1 Parameter List

Parameter No.	Name	Unit	Setting Range	Factory Setting	Setting Invalidation
Pn000	Binary Pn000.0: Servo ON Pn000.1: Forward rotation input signal prohibited (P-OT) Pn000.2: Reverse rotation input signal prohibited (N-OT) Pn000.3: Alarm output when instantaneous power loss	—	0~1111	0	After restart
Pn001	Binary Pn001.0: CCW,CW selection Pn001.1: Reserved Pn001.2: Reserved Pn001.3: 2nd electronic gear enabled	—	0~1111	0	After restart
Pn002	Binary Pn002.0: Electronic gear switching mode Pn002.1: Reserved Pn002.2: Reserved Pn002.3: Reserved	—	0~0111	0010	After restart
Pn003	Binary Pn003.0: Reserved Pn003.1: Reserved Pn003.2: Low speed compensation Pn003.3: Overload enhancement	—	0~1111	0	After restart
Pn004	Hex Pn004.0: Stop mode Pn004.1: Error counter clear mode Pn004.2: Reference pulse form Pn004.3: Inverses pulse	—	0~0x3425	0	After restart

Parameter No.	Name	Unit	Setting Range	Factory Setting	Setting Invalidation
Pn005	Hex Pn005.0: Torque feedforward mode Pn005.1: Control mode [0] Speed control(parameter reference) [1] Position control(pulse train) [2] Speedcontrol(contactreference) [3] Speed control(contact reference)←→ position control(pulse train) [4] Position control(pulse train)←→ position control(inhibit) [5] Position control (contact reference) [6] Reserved Pn005.2: Out-of-tolerance alarm selection Pn005.3: Servomotor model	—	0~0x3361	0	After restart
Pn006	Hex Pn006.0: Bus mode Pn006.1: Reserved Pn006.2: Low frequency jitter suppression switch Pn006.3: Reference input filter for open collector signal	—	0~0x2103	0x0000	After restart
Pn007	Binary Pn007.0: wider the width of C pulse or not Pn007.1: Reserved Pn007.2: Reserved Pn007.3: Reserved	—	0~0001	0	After restart
Pn100	Online autotuning setting 0: Manual gain adjustment 1,2,3=Normal mode;4,5,6=Vertical load 1,4 = Load inertia without variation; 2,5 = Load inertia with little variation; 3,6=Load inertia with great variation	—	0~6	0	After restart
Pn101	Machine rigidity setting	—	0~15	5	Immediately
Pn102	Speed loop gain	Hz	1~4000	320	Immediately
Pn103	Speed loop integral time constant	0.25ms	1~4096	40	Immediately
Pn104	Position loop gain	Hz	0~1000	40	Immediately
Pn105	Torque reference filter time constant	0.25ms	0~250	2	Immediately
Pn106	Load inertia percentage	—	0~20000	0	Immediately
Pn107	2nd speed loop gain	Hz	1~4000	320	Immediately
Pn108	2nd speed loop integral time constant	0.25ms	1~4096	40	Immediately
Pn109	2nd position loop gain	Hz	0~1000	40	Immediately
Pn110	2nd torque reference filter time constant	0.25ms	0~250	2	Immediately
Pn111	Speed bias	rpm	0~300	0	Immediately
Pn112	Feedforward	%	0~100	0	Immediately

Parameter No.	Name	Unit	Setting Range	Factory Setting	Setting Invalidation
Pn113	Feedforward filter	0.25ms	0~640	0	Immediately
Pn114	Torque feedforward	%	0~100	0	Immediately
Pn115	Torque feedforward filter	0.25ms	0~640	0	Immediately
Pn116	P/PI switching condition 0:Torque reference percentage 1:Value of offset counter 2:Value of acceleration speed setting 3:Value of speed setting 4:Fixed PI	—	0~4	0	After restart
Pn117	Torque switching threshold	%	0~300	200	Immediately
Pn118	Offset counter switching threshold	reference pulse	0~10000	0	Immediately
Pn119	Setting acceleration speed switching threshold	10rpm/s	0~3000	0	Immediately
Pn120	Setting speed switching threshold	rpm	0~10000	0	Immediately
Pn121	Gain switching condition 0:Fix to 1st group gain 1:External switch gain switching 2:Torque percentage 3:Value of offset counter 4:Value of acceleration speed setting 5:Value of speed setting 6:Speed reference input 7: actual motor speed	—	0~7	0	After start
Pn122	Switching delay time	0.25ms	0~20000	0	Immediately
Pn123	Threshold switching level	—	0~20000	0	Immediately
Pn124	Reserved	—	—	—	—
Pn125	Position gain switching time	0.25ms	0~20000	0	Immediately
Pn126	Hysteresis switching	—	0~20000	0	Immediately
Pn127	Low speed detection filter	0.25ms	0~100	10	Immediately
Pn128	Speed gain acceleration relationship during online autotuning	—	0~3	3	Immediately
Pn129	Low speed correction coefficient	—	0~30000	0	Immediately
Pn130	Friction load	0.1%	0~3000	0	Immediately
Pn131	Friction compensation speed hysteresis area	rpm	0~100	0	Immediately
Pn132	Sticking friction load	0.1%/1000rpm	0~1000	0	Immediately
Pn200	PG divided ratio	Puls	1~2500	2500	After restart
Pn201	1st electronic gear numerator	—	1~65535	1	After restart
Pn202	Electronic gear denominator	—	1~65535	1	After restart
Pn203	2nd electronic gear numerator	—	1~65535	1	After restart
Pn204	Position reference Acceleration	0.25ms	0~32767	0	Immediately

Parameter No.	Name	Unit	Setting Range	Factory Setting	Setting Invalidation
	/deceleration time constant				
Pn205	Position reference filter form selection	—	0~1	0	After restart
Pn206	Pluse input port and synchronization mode selection	—	0~0x0033	0	After restart
Pn304	Parameter speed	rpm	-6000~6000	500	Immediately
Pn305	JOG speed	rpm	0~6000	500	Immediately
Pn306	Soft start acceleration time	ms	0~10000	0	Immediately
Pn307	Soft start deceleration time	ms	0~10000	0	Immediately
Pn308	Speed filter time constant	ms	0~10000	0	Immediately
Pn309	S curve risetime	ms	0~10000	0	Immediately
Pn310	Speed reference curve form 0:Slope 1:S curve 2:1 st order filter 3:2 nd order filter	—	0~3	0	After restart
Pn311	S form selection	—	0~3	0	Immediately
Pn316	Internal speed 1	rpm	-6000~6000	100	Immediately
Pn317	Internal speed 2	rpm	-6000~6000	200	Immediately
Pn318	Internal speed 3	rpm	-6000~6000	300	Immediately
Pn319	Internal speed 4	rpm	-6000~6000	-100	Immediately
Pn320	Internal speed 5	rpm	-6000~6000	-200	Immediately
Pn321	Internal speed 6	rpm	-6000~6000	-300	Immediately
Pn322	Internal speed 7	rpm	-6000~6000	500	Immediately
Pn401	Forward torque internal limit①	%	0~300	300	Immediately
Pn402	Reverse torque internal limit①	%	0~300	300	Immediately
Pn403	Forward external torque limit①	%	0~300	100	Immediately
Pn404	Reverse external torque limit①	%	0~300	100	Immediately
Pn405	Plug braking torque limit	%	0~300	300	Immediately
Pn406	Speed limit during torque control	rpm	0~6000	1500	Immediately
Pn407	Notch filter 1 frequency	Hz	50~2000	2000	Immediately
Pn408	Notch filter 1 depth	—	0~11	1	Immediately
Pn409	Notch filter 2 frequency	Hz	50~2000	2000	Immediately
Pn410	Notch filter 2 depth	—	0~11	1	Immediately
Pn411	Low frequency jitter frequency	0.1Hz	50~500	100	Immediately
Pn412	Low frequency jitter damp	—	0~200	25	Immediately
Pn413	Torque control delay time	0.25ms	1~2000	100	Immediately
Pn414	Torque control speed hysteresis	rpm	10~1000	50	Immediately
Pn500	Positioning error	Puls	0~5000	10	Immediately
Pn501	Coincidence difference	rpm	0~100	10	Immediately
Pn502	Reserved	—	—	—	—
Pn503	Rotation detection speed TGON	rpm	0~3000	20	Immediately
Pn504	Offset counter overflow alarm	256Puls	1~32767	1024	Immediately
Pn505	Servo ON waiting time	ms	-2000~2000	0	Immediately

Parameter No.	Name	Unit	Setting Range	Factory Setting	Setting Invalidation
Pn506	Basic waiting flow	10ms	0~500	0	Immediately
Pn507	Brake waiting speed	rpm	10~100	100	Immediately
Pn508	Brake waiting time	10ms	10~100	50	Immediately
Pn509	Allocate input signal to terminal	—	0~0xEEEE	0x3210	After restart
Pn510	Allocate input signal to terminal	—	0~0xEEEE	0x7654	After restart
Pn511	Allocate outputsignal to terminal	—	0~0x0888	0x0210	After restart
Pn512	Bus control input node low-bit enable	—	0~1111	0	Immediately
Pn513	Bus control input node low-bit enable	—	0~1111	0	Immediately
Pn514	Input port filter	0.2ms	0~1000	1	Immediately
Pn515	Alarm port filter	0.2ms	0~3	1	Immediately
Pn516	Input port signal inversion	—	0~1111	0	Immediately
Pn517	Input port signal inversion	—	0~1111	0	Immediately
Pn518	Dynamic brake time	0.5ms	50~2000	125	Immediately
Pn519	Reserved	—	—	—	—
Pn520	Position complete time	0.25ms	0~60000	500	Immediately
Pn521	Reserved	—	—	—	—
Pn522	Reserved	—	—	—	—
Pn523	Reserved	—	—	—	—
Pn525	Overload alarm threshold	%	100~150	100	Immediately
Pn526	Reserved	—	—	—	—
Pn527	Reserved	—	—	—	—
Pn528	Output signal inverse	—	0~1111	0	Immediately
Pn600	Position pulse in point to point control	10000P	-9999~9999	0	Immediately
Pn601	Position pulse in point to point control	1P	-9999~9999	0	Immediately
				
Pn630	Position pulse in point to point control	1P	-9999~9999	0	Immediately
Pn631	Position pulse in point to point control	1P	-9999~9999	0	Immediately
Pn632	Point to point speed control	rpm	0~3000	500	Immediately
				
Pn647	Point to point speed control	rpm	0~3000	500	Immediately
Pn648	Point to point1st order filter	0.25ms	0~32767	0	Immediately
				
Pn663	Point to point1st order filter	0.25ms	0~32767	0	Immediately
Pn664	Stop time	50ms	0~300	10	Immediately
				
Pn679	Stop time	50ms	0~300	10	Immediately
Pn680	Reserved	—	—	—	—
Pn681	Hex Pn681.0:Single/cyclic, start/reference point selection Pn681.1:Change step and start mode Pn681.2:Change step input signal mode Pn681.3:Reserved	—	0~0x0333	0x0000	Immediately

Parameter No.	Name	Unit	Setting Range	Factory Setting	Setting Invalidation
Pn682	Programme mode	—	0~1	0	Immediately
Pn683	Programme start step	—	0~15	0	Immediately
Pn684	Programme stop step	—	0~15	1	Immediately
Pn685	Search travel speed in position control (contact reference); Speed of finding reference point (hitting the origin signal ORG) in position homing control.	rpm	0~3000	1500	Immediately
Pn686	Leave travel switch speed in position control(contact reference); Speed of finding reference point (leaving the origin signal ORG) in position homing control.	rpm	0~200	30	Immediately
Pn687	Position teaching pulse	10000P	-9999~9999	0	Immediately
Pn688	Position teaching pulse	1P	-9999~9999	0	Immediately
Pn689	Homing Mode Setting	—	0~0111	0	After restart
Pn690	Number of error pulses during homing	10000pulse	0~9999	0	Immediately
Pn691	Number of error pulses during homing	1pulse	0~9999	0	Immediately
Pn700	Hex Pn700.0:MODBUS communication baud rate Pn700.1:MODBUS protocol selection Pn700.2:Communication protocol selection Pn700.3:Reserved	—	0~0x0085	0x0051	After restart
Pn701	MODBUS axis address	—	1~247	1	After restart
Pn702	Reserved	—	—	—	—
Pn703	CANcommunication speed	—	0x0015	0x0004	After restart
Pn704	CAN communication contact	—	1~127	1	After restart
Pn840	Hex Pn840.0: Encoder model selection Pn840.1: Reserved Pn840.2: Power level of MachineReserved Pn840.3: Reserved	—	0x0006~ 0x0306	—	After restart

Note: ① The setting range and factory setting of Pn401 to Pn405 depend on the actual overload capacity.

A.2 Description of Parameter Type

Type	Parameter No.	Description
Function selection switches	Pn000~Pn007	Control mode, stop mode, and some functions selection
Parameters of servo gain	Pn102~Pn134	Position gain, speed gain, rigidity, etc.
Position control related parameters	Pn200~Pn206	PG divided ratio, electronic gear, etc.
Speed control related parameters	Pn304~Pn322	Speed reference input, soft start, etc.
Torque control related parameters	Pn401~Pn410	Torque limit, etc.
Parameters to control I/O port	Pn500~Pn528	Allocation of I/O port function
Point-to-point control and homing control related parameters	Pn600~Pn688	Internal point-to-point control and homing control related parameters
Communication parameters	Pn700~Pn704	Setting of communication parameters

A.3 Parameters in detail

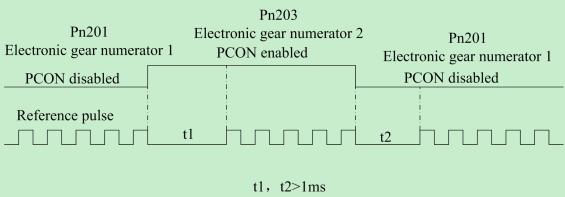
Parameter No.	Description	Setting Validation	Control Mode	Function and Meaning
Pn000	Binary	After restart	ALL	<p>Pn000.0 Servo ON [0] External S-ON enabled. [1] External S-ON disabled. Servomotor excitation signal is turned ON automatically after S-RDY is output.</p> <p>Pn000.1 Forward rotation input signal prohibited (P-OT) [0] External P-OT enabled. Operate in the time sequence setting in Pn004.0 when travel limit occurs. [1] External P-OT disabled.</p> <p>Pn000.2 Reverse rotation input signal prohibited (N-OT) [0] External N-OT enabled. Operate in the time sequence setting in Pn004.0 when travel limit occurs. [1] External N-OT disabled.</p> <p>Pn000.3 Alarm output when instantaneous power loss [0] Instantaneous power loss for one period with no alarm output [1] Instantaneous power loss for one period with alarm output</p>
Pn001	Binary	After restart	Pn001.0 ALL Pn001.1 T Pn001.2 P, S Pn001.3 P	<p>Pn001.0 CCW, CW selection [0] Sets CCW as forward direction [1] Sets CW as forward direction</p> <p>Pn001.1 Reserved</p> <p>Pn001.2 Reserved</p> <p>Pn001.3 2nd electronic gear enabled [0] Without 2nd electronic gear, PCON signal is used to switch P/PI [1] 2nd electronic gear is enabled, PCON signal is only used as 2nd electronic gear when Pn005.3 is set to 1.</p>
Pn002	Binary	After restart	ALL	<p>Pn002.0 Electronic gear switching mode [0] Corresponding time sequence</p>  <p>[1] Corresponding time sequence</p>

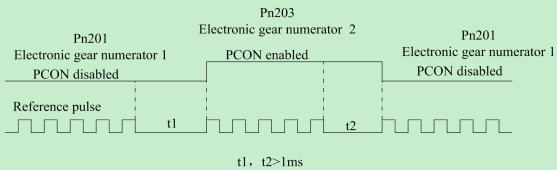
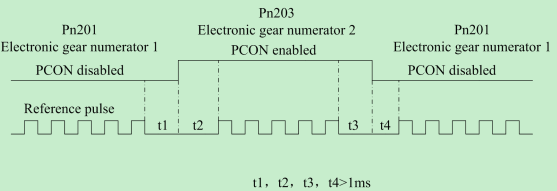
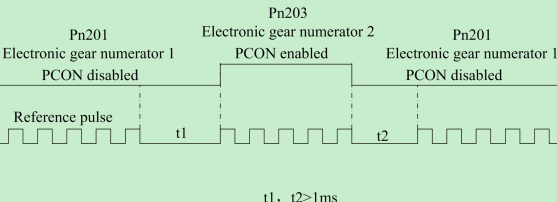
Parameter No.	Description	Setting Validation	Control Mode	Function and Meaning
				 <p data-bbox="933 448 1332 481">Time sequence when Pn002.0=0 or 1</p>  <p data-bbox="933 739 1157 772">Error time sequence</p>  <p data-bbox="933 1030 1141 1142"> Pn002.1 Reserved Pn002.2 Reserved Pn002.3 Reserved </p>
Pn003	Binary	After restart	ALL	<p data-bbox="933 1160 1141 1187">Pn003.0 Reserved</p> <p data-bbox="933 1198 1141 1225">Pn003.1 Reserved</p> <p data-bbox="933 1236 1332 1263">Pn003.2 Low speed compensation</p> <p data-bbox="933 1276 1460 1433">[0] Without low speed correction [1] With low speed correction to avoid servomotor creeping, but the degree of correction is determined by the setting in Pn219.</p> <p data-bbox="933 1444 1300 1471">Pn003.3 Overload enhancement</p> <p data-bbox="933 1485 1476 1680">[0] Without overload enhancement function [1] With overload enhancement function, which can enhance the overload capacity when servomotor exceeds the 2 times rated overload. It is used in frequent power ON/OFF occasions.</p>
Pn004	Hex	After restart	Pn004.0 ALL Pn004.1 P Pn004.2 P Pn004.3 P	<p data-bbox="933 1700 1157 1727">Pn004.0 Stop Mode</p> <p data-bbox="933 1740 1460 1807">[0] Stops the servomotor by applying DB and then releases DB.</p> <p data-bbox="933 1821 1125 1848">[1] Coast to a stop.</p> <p data-bbox="933 1861 1508 1973">[2] Stops the servomotor by DB when servo OFF, stops the servomotor by plug braking when overtravel, then places it into coast (power OFF) mode.</p> <p data-bbox="933 1986 1492 2054">[3] Makes the servomotor coast to a stop state when servo OFF, stops the servomotor by plug braking</p>

Parameter No.	Description	Setting Validation	Control Mode	Function and Meaning
				<p>when overtravel, then places it into coast (power OFF) mode.</p> <p>[4]Stops the servomotor by DB when servo OFF, stops the servomotor by plug braking when overtravel, then places it into zero clamp mode.</p> <p>[5]Makes the servomotor coast to a stop state when servo OFF, stops the servomotor by plug braking when overtravel, then places it into zero clamp mode.</p> <p>Pn004.1 Error counter clear mode</p> <p>[0]Clearerror pulse when S-OFF, donot when overtravel.</p> <p>[1]Do not clear error pulse.</p> <p>[2]Clearerror pulse when S-OFF orovertravel (excep for zero clamp)</p> <p>Pn004.2 Reference pulse form</p> <p>[0]Sign + Pulse</p> <p>[1]CW+CCW CW + CCW</p> <p>[2]A + B (×1)</p> <p>[3]A + B (×2)</p> <p>[4]A + B (×4)</p> <p>Pn004.3 Inverses pulse</p> <p>[0]Do not inverse PULS reference and SIGN reference.</p> <p>[1]Do not inverse PULS reference; Inverses SIGN reference.</p> <p>[2]Inverse PULS reference;Do not inverse SIGN reference.</p> <p>[3]Inverse PULS reference and SIGN reference.</p>
Pn005	Hex	After restart	<p>Pn005.0 P, S</p> <p>Pn005.1 ALL</p> <p>Pn005.2 P</p>	<p>Pn005.0 Torque feedforward form</p> <p>[0]Usegeneral torque feedforward</p> <p>[1] Usehigh-speed torque feedforward</p> <p>Pn005.1 Control mode</p> <p>[0]Speed control(Parameter reference)</p> <p>PCON is invalid.</p> <p>[1]Position control(pulse train reference)</p> <p>PCON: OFF, PI control; ON, P control</p> <p>[2]Speed control(contact reference)←→speed Control(zero reference)</p> <p>PCON , PCL , NCL : OFF Switches to position control(zero reference)</p> <p>[3]Speed control(contact reference)←→position control(pulse train reference)</p> <p>PCON , PCL , NCL : OFF Switches to position control(pulse train reference)</p> <p>[4]Positin control(pulse train reference)←→position</p>

Parameter No.	Description	Setting Validation	Control Mode	Function and Meaning
				<p>control(INHIBIT) PCON: OFF Position control(pulse train reference); ON position control(INHIBIT) [5]Position control(contact reference) PCON: Used to change step PCL, NCL: Used to search reference point or start [6] Reserved Pn005.2 Out-of-tolerance alarm selection [0]Out-of-tolerance alarm disabled [1]Out-of-tolerance alarm enabled. Outputs alarm when the value of error counter exceeds Pn504 setting value. [2] Reserved [3] Reserved Pn005.3 Servomotor model selection^① [0]EMJ [1]EMG [2] EML</p>
Pn006	Hex	After restart		<p>Pn006.0 Bus type selection [0]No bus [1] Reserved [2] Reserved [3]CANopen Pn006.1 Reserved Pn006.2Low-frequency vibration suppression switch [0]Low-frequency vibration suppression function disabled [1]Low-frequency vibration suppression function enabled Pn006.3 Reference input filter for open collector signal [0] When pulse is difference input, the max value of servo receiving pulse frequency^②≤4M [1] When pulse is difference input, the max value of servo receiving pulse frequency^②≤650K [2] When pulse is difference input, the max value of servo receiving pulse frequency^②≤150K</p>
Pn007	Binary	After restart		<p>Pn007.0: wider the width of C pulse or not [0] standard width of C pulse [1] wider the width of C pulse Pn007.1: reserved Pn007.2: reserved Pn007.3: reserved</p>

Parameter No.	Description	Setting Validation	Control Mode	Function and Meaning
Pn100	Online autotuning setting	After restart	P, S	<p>[0] Manual gain adjustment [1,2,3] Normal mode [4,5,6] Vertical load [1,4] Load inertia without variation [2,5] Load inertia with little variation [3,6] Load inertia with great variation</p> <p>Note: 1.Autotuning is invalid when servomotor max.speed is less than 100rpm.Manual gain adjustment is used. 2.Autotuning is invalid when servomotor acceleration /deceleration speed is less than 5000rpm/s. Manual gain adjustment is used. 3.Autotuning is invalid when mechanical clearance is too big during operation. Manual gain adjustment is used. 4.Autotuning is invalid when the difference of different speed load is too great. Manual gain adjustment is used.</p>
Pn101	Machine rigidity setting	Immediately	P, S	The response speed of servo system is determined by this parameter. Normally, the rigidity should be set a little larger. However, if it is too large, it would suffer mechanical impact. It should be set a little smaller when large vibration is present. This parameter is only valid in autotuning.
Pn102	Speed loop gain	Immediately	P, S	This parameter determines speed loop gain. Unit: Hz
Pn103	Speed loop integral time constant	Immediately	P, S	Decreases the value of this parameter to shorten positioning time and enhance speed response. Unit: 0.25ms
Pn104	Position loop gain	Immediately	P	This parameter determines position loop gain. Decreases this value to enhance servo rigidity, but vibration will occur if the value is too large. Unit: 1/s
Pn105	Torque reference filter time constant	Immediately	P, S	Torque reference filter can eliminate or lighten mechanical vibration, but incorrect setting will result to mechanical vibration.Unit:0.25ms
Pn106	Load inertia percentage	Immediately	P, S	Setting value=(load inertia/rotor inertia) × 100 Unit: %
Pn107	2nd speed loop gain	Immediately	P, S	The meanings of these parameters are the same as Pn102~Pn105. These parameters are only needed to set when two types of gain function are enabled.
Pn108	2nd speed loop integral time constant	Immediately	P, S	
Pn109	2nd position loop gain	Immediately	P	
Pn110	2nd torque reference	Immediately	P, S	

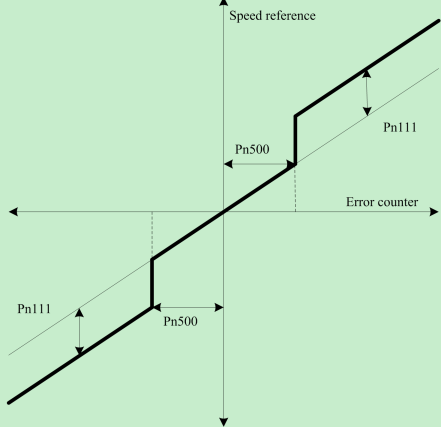
Parameter No.	Description	Setting Validation	Control Mode	Function and Meaning
	filter time constant			
Pn111	Speed bias	Immediately	P	<p>This parameter setting can shorten positioning time. However, if it is too large or does not cooperate with Pn111 correctly, vibration will occur. The relationship with speed reference, error counter, positioning error is shown in the following chart.</p> 
Pn112	Feedforward	Immediately	P	<p>It is used to set position feedforward. The response speed is faster and position error is less when this parameter setting is higher. Vibration will occur if the value is set too large. Unit: %</p>
Pn113	Feedforward filter	Immediately	P	<p>It is used to ease mechanical vibration due to position feedforward. The feedforward lag will be enlarged and result to vibration if the value is set too large. Unit: 0.25ms</p>
Pn114	Torque feedforward	Immediately	P, S	<p>It is used to set torque feedforward, and enhance response speed. Set the load inertia percentage(Pn106) correctly to enable this function in manual gain adjustment mode. Unit: %</p>
Pn115	Torque feedforward filter	Immediately	P, S	<p>It is used to ease mechanical vibration due to torque feedforward. Unit: 0.25ms</p>
Pn116	P/PI switching condition	After restart	P, S	<p>0:Torque reference percentage 1:Value of offset counter 2:Value of acceleration speed setting 3:Value of speed setting 4:Fixed PI</p>
Pn117	Torque switching threshold	After restart	P, S	<p>Threshold of torque to switch PI control to P control. Unit: %</p>
Pn118	Offset counter switching threshold	Immediately	P	<p>Threshold of error counter to switch PI control to P control. Unit: pulse</p>

Parameter No.	Description	Setting Validation	Control Mode	Function and Meaning
Pn119	Setting acceleration speed switching threshold	Immediately	P, S	Threshold of acceleration speed to switch PI control to P control. Unit: 10rpm/s
Pn120	Setting speed switching threshold	Immediately	P, S	Threshold of speed to switch PI control to P control. Unit: rpm
Pn121	Gain switching condition	After restart	P, S	0:Fix to 1st group gain 1:External switch gain switching(G-SEL) 2:Torque percentage 3:Value of offset counter 4:Value of acceleration speed setting (10rpm) 5:Value of speed setting 6:Speed reference input 7: actual motor speed
Pn122	Switching delay time	Immediately	P, S	Delay time of switching gain when switching condition is satisfied.
Pn123	Switch threshold level	Immediately	P, S	Gain switching trigger level
Pn125	Position gain switching time	Immediately	P	This parameter is used to smooth transition if the change of the two groups of gain is too large.
Pn126	Hysteresis switching	Immediately	P, S	This parameter is used to set the operation hysteresis of gain switching.
Pn127	Low speed detection filter	Immediately	P, S	This parameter is used to filter in low speed detection. The speed detection will be lagged if the value is too large.
Pn128	Speed gain acceleration relationship during online autotuning	Immediately	P, S	The increasing multiple of speed loop gain is the same rigidity during online autotuning. The speed loop gain is larger when this value is higher.
Pn129	Low speed correction coefficient	Immediately	P, S	The intensity of anti-friction and anti-creeping at low speed. Vibration will occur if this value is set too large.
Pn130	Friction Load	Immediately	P, S	Frictin load or fixed load compensation
Pn131	Friction compensation speed hysteresis area	Immediately	P, S	Threshold of friction compensation start
Pn132	Sticking friction load	Immediately	P, S	Sticking damp which is in direct proportion to speed.
Pn200	PG divided ratio	After restart	P, S	Analog encoder output orthogonal difference pulses. The meaning of this value is the number of analog encoder output orthogonal difference pulses per one servomotor rotation.
Pn201	1st electronic gear numerator	After restart	P	The electronic gear enables the reference pulse to relate with the servomotor travel distance, so the host controller doesn't change the mechanical deceleration ratio and encoder pulses. In fact, it is the setting of frequency doubling or frequency division to the reference pulses.
Pn202	Electronic gear denominator	After restart	P	
Pn203	2nd electronic gear numerator	After restart	P	

Parameter No.	Description	Setting Validation	Control Mode	Function and Meaning
				$\frac{\text{Numerator}(Pn201 \text{ or } Pn203)}{\text{Denominator}(Pn202)}$
Pn204	Position reference acceleration /deceleration time constant	Immediately	P	This value is used to smooth the input pulses. The effect of smoothness is better when the value is higher, but lag will occur if the value is too large.
Pn205	Position reference filter form selection	After restart	P	[0]: 1st order filter [1]: 2nd order filter
Pn206	Pulse input selection	After restart	P	<p>Pn206.0 Pulse input port selection</p> <p>[0]: use pulse input themselves [1]: use A-axis pulse input port [2]: use B-axis pulse input port [3]: use C-axis pulse input port</p> <p>Pn206.1 Synchronize selection</p> <p>[0]: A-axis and B-axis use the same pulse input port setted by Pn206.0, C-axis use C-axis pulse input port [1]: A-axis and C-axis use the same pulse input port setted by Pn206.0, B-axis use B-axis pulse input port [2]: B-axis and C-axis use the same pulse input port setted by Pn206.0, A-axis use A-axis pulse input port [3]: A-axis, B-axis and C-axis use the same pulse input port</p>
Pn300	Speed reference input gain	Immediately	S	The corresponding speed to 1V analog input
Pn304	Parameter speed	Immediately	S	The parameter can be set to positive or negative. When control mode is set to D, it determines the speed of motor . The servomotor speed is determined by this parameter when Pn005.1=D.
Pn305	JOG speed	Immediately	S	It is used to set JOG rotation speed, and the direction is determined by the pressing key during JOG operation.
Pn306	Soft start acceleration time	Immediately	S	The time for trapeziform acceleration to accelerate to 1000rpm. Unit: ms
Pn307	Soft start deceleration time	Immediately	S	The time for trapeziform deceleration to decelerate to 1000rpm. Unit: ms
Pn308	Speed filter time constant	Immediately	S	1st order filter time constant Unit: ms
Pn309	S curve risetime	Immediately	S	The time for transition from one point to another point in S curve.

Parameter No.	Description	Setting Validation	Control Mode	Function and Meaning																																				
Pn310	Speed reference curve form	After restart	S	0:Slope 1:S curve 2:1 st order filter 3:2 nd order filter																																				
Pn311	S formselection	After restart	S	This value determines the transition form of S curve.																																				
Pn316	Speed internal 1	Immediately	S	Internal speed is enabled when Pn005.1=3~6																																				
Pn317	Speed internal 2	Immediately	S	<table border="1"> <thead> <tr> <th colspan="3">Input signal</th> <th rowspan="2">operating speed</th> </tr> <tr> <th>/</th> <th>/P-CL</th> <th>/N-CL</th> </tr> </thead> <tbody> <tr> <td rowspan="3">OFF(H)</td> <td>OFF(H)</td> <td>OFF(H)</td> <td>Zero speed or switch</td> </tr> <tr> <td>OFF(H)</td> <td>ON(L)</td> <td>SPEED1</td> </tr> <tr> <td>ON(L)</td> <td>OFF(H)</td> <td>SPEED2</td> </tr> <tr> <td rowspan="4">ON(L)</td> <td>ON(L)</td> <td>ON(L)</td> <td>SPEED3</td> </tr> <tr> <td>OFF(H)</td> <td>OFF(H)</td> <td>SPEED4</td> </tr> <tr> <td>OFF(H)</td> <td>ON(L)</td> <td>SPEED5</td> </tr> <tr> <td>ON(L)</td> <td>OFF(H)</td> <td>SPEED6</td> </tr> <tr> <td></td> <td>ON(L)</td> <td>ON(L)</td> <td>SPEED7</td> </tr> </tbody> </table>			Input signal			operating speed	/	/P-CL	/N-CL	OFF(H)	OFF(H)	OFF(H)	Zero speed or switch	OFF(H)	ON(L)	SPEED1	ON(L)	OFF(H)	SPEED2	ON(L)	ON(L)	ON(L)	SPEED3	OFF(H)	OFF(H)	SPEED4	OFF(H)	ON(L)	SPEED5	ON(L)	OFF(H)	SPEED6		ON(L)	ON(L)	SPEED7
Input signal			operating speed																																					
/	/P-CL	/N-CL																																						
OFF(H)	OFF(H)	OFF(H)	Zero speed or switch																																					
	OFF(H)	ON(L)	SPEED1																																					
	ON(L)	OFF(H)	SPEED2																																					
ON(L)	ON(L)	ON(L)	SPEED3																																					
	OFF(H)	OFF(H)	SPEED4																																					
	OFF(H)	ON(L)	SPEED5																																					
	ON(L)	OFF(H)	SPEED6																																					
	ON(L)	ON(L)	SPEED7																																					
Pn318	Speed internal 3	Immediately	S																																					
Pn319	Speed internal 4	Immediately	S																																					
Pn320	Speed internal 5	Immediately	S																																					
Pn321	Speed internal 6	Immediately	S																																					
Pn322	Speed internal 7	Immediately	S																																					
Pn401	Forward torque internal limit	Immediately	P, S	Servomotor output torque limit value (depending on the actual overload capacity) .																																				
Pn402	Reverse torque internal limit	Immediately	P, S																																					
Pn403	Forward external torque limit	Immediately	P, S																																					
Pn404	Reverse external torque limit	Immediately	P, S																																					
Pn405	Plug braking torque limit	Immediately	P, S																																					
Pn406	Speed limit during torque control	Immediately	T	Servomotor output torque limit value during torque control																																				
Pn407	Notch filter 1 frequency	Immediately	P, S	Notch filter 1 frequency	1. In some conditions, vibration will be picked up and response will be lagged after notch filter is set. 2. When notch filter frequency is set to 5000, the notch filter is invalid.																																			
Pn408	Notch filter 1 depth	Immediately	P, S	Notch filter 1 depth																																				
Pn409	Notch filter 2 frequency	Immediately	P, S	Notch filter 2 frequency																																				
Pn410	Notch filter 2 depth	Immediately	P, S	Notch filter 2 depth																																				
Pn411	Low frequency vibration frequency	Immediately	P, S	Frequency of low frequency vibration with load.																																				
Pn412	Low frequency vibration damp	Immediately	P, S	Attenuation damp of low frequency vibration with load. It does not need to change.																																				

Parameter No.	Description	Setting Validation	Control Mode	Function and Meaning
Pn413	Torque control delay time	Immediately	T	These parameters are only enabled in position control mode.
Pn414	Torque control speed hysteresis	Immediately	T	
Pn500	Positioning error	Immediately	P	Outputs /COIN signal when error counter is less than this value.
Pn501	Coincidence difference	Immediately	P	Outputs /VCMP signal when the difference between speed reference value and speed feedback value is less than this value.
Pn502	Zero clamp speed	Immediately	S	The servomotor is locked in the form of temporary position loop when the speed corresponding to the analog input is less than this value.
Pn503	Rotation detection speed TGON	Immediately	P, S	When the servomotor speed exceeds this parameter setting value, it means that the servomotor has already rotated steadily and outputs /TGON signal.
Pn504	Offset counter overflow alarm	Immediately	P	When the value in error counter exceeds this parameter setting value, it means that error counter alarm has occurred and outputs alarm an signal.
Pn505	Servo ON waiting time	Immediately	P, S	These parameters are only enabled when the port output parameters are allocated with /BK signal output.
Pn506	Basic waiting flow	Immediately	P, S	These parameters are used to keep braking (prevent from gravity glissade or continuous outside force on servomotor) time sequence.
Pn507	Brake waiting speed	Immediately	P, S	Servo ON waiting time: ① For the parameter is plus, /BK signal is output firstly when servo-ON signal is input, and then servomotor excitation signal is created after delaying the parameter setting time. ② For the parameter is minus, servomotor excitation signal is output firstly when servo-ON signal is input, and then /BK signal is created after delaying the parameter setting time.
Pn508	Brake waiting time	Immediately	P, S	Basic waiting flow: Standard setting: /BK output (braking action) and servo-OFF are at the same time. Now, the machine movable part may shift slightly due to gravity according to mechanical configuration and character; it can be eliminated by using the parameters when the servomotor is at stop or at a low speed. Brake waiting speed: /BK signal is output when the servomotor speed is decreased below the parameter setting value at

Parameter No.	Description	Setting Validation	Control Mode	Function and Meaning
				servo-OFF. Brake waiting time: BK signal is output when the delay time exceeds the parameter setting value after servo-OFF. /BK signal is output as long as either of the brake waiting speed or brake waiting time is satisfied.
Pn509	Allocate input port to signal, one port with four bits(hex)	After restart	P, S	Pn509.0 corresponding port CN1_A/B/C_10 Pn509.1 corresponding port CN1_A/B/C_11 Pn509.2 corresponding port CN1_A/B/C_12
Pn510	Allocate input port to signal, one port with four bits(hex)	After restart	P, S	Pn509.3 corresponding port CN1_A/B/C_13 Pn510.0 corresponding port CN1_A/B/C_14 Pn510.1 corresponding port CN1_A/B/C_15 Pn510.2 corresponding port CN1_A/B/C_16 Pn510.3 corresponding port CN1_A/B/C_17 Corresponding signal of each data is shown as following: 0: S-ON 1: P-CON 2: P-OT 3: N-OT 4: ALMRST 5: CLR 6: P-CL 7: N-CL 8: G-SEL 9: JDPOS-JOG+ A: JDPOS-JOG- B: JDPOS-HALT C: HmRef D: SHOM E: ORG
Pn511	Output signal allocation	After restart	P, S	Pn511.0 corresponding port CN1_A/B/C_7 , CN1_A/B/C_8 Pn511.1 corresponding port CN1_A/B/C_1 , CN1_A/B/C_2 Pn511.2 corresponding port CN1_A/B/C_5 , CN1_A/B/C_6 Corresponding signal of each data is shown as follows: 0: /COIN/VCMP 1: /TGON 2: /S-RDY 3: /CLT 4: /BK

Parameter No.	Description	Setting Validation	Control Mode	Function and Meaning
				5: /PGC 6: OT 7: /RD 8: /HOME
Pn512	Bus control input node low-bit enabled	Immediately	P, S	Bus communication input port enabled: [0]: Disabled [1]: Enabled Pn512.0→CN1_A/B/C_10 Pn512.1→ CN1_A/B/C_11 Pn512.2→ CN1_A/B/C_12 Pn512.3→ CN1_A/B/C_13
Pn513	Bus control input node low-bit enabled	Immediately	P, S	Pn513.0→ CN1_A/B/C_14 Pn513.1→ CN1_A/B/C_15 Pn513.2→ CN1_A/B/C_16 Pn513.3→ CN1_A/B/C_17
Pn514	Input port filter	Immediately	P, S	It is used to set input port filter time. The signal will be lagged if the parameter setting is too high.
Pn515	Alarm port filter	Immediately	P, S	It is used to set alarm filter time. The signal will be lagged if the parameter setting is too high
Pn516	Input port signal inversion	Immediately	P, S	[0]: Do not inverse signal. [1]: Inverse signal Pn516.0→CN1_A/B/C_10 inversion Pn516.1→CN1_A/B/C_11 inversion Pn516.2→CN1_A/B/C_12 inversion
Pn517	Input port signal inversion	Immediately	P, S	Pn516.3→CN1_A/B/C_13 inversion Pn517.0→CN1_A/B/C_14 inversion Pn517.1→CN1_A/B/C_15 inversion Pn517.2→CN1_A/B/C_16 inversion Pn517.3→CN1_A/B/C_17 inversion
Pn518	Dynamic brake time	Immediately	P, S	Dynamic brake time
Pn519	Reserved	—	—	—
Pn520	Position complete time	Immediately	P,S	Position complete time
Pn521	Reserved	—	—	—
Pn522	Reserved	—	—	—
Pn523	Reserved	—	—	—
Pn525	Overload alarm threshold	Immediately	P, S	When load percentage is larger than overload alarm threshold, A04 will occur soon. Pn525 is recommended to set below 120, otherwise the servo drive and motor will be damaged.
Pn526	Reserved	—	—	—

Parameter No.	Description	Setting Validation	Control Mode	Function and Meaning
Pn527	Reserved	—	—	—
Pn528	Output signal inverse	—	—	[0]: Do not inverse signal. [1]: Inverse signal Pn528.0→CN1_A/B/C_3,4 inversion Pn528.0→CN1_A/B/C_7,8 inversion Pn528.0→CN1_A/B/C_1,2inversion Pn528.0→CN1_A/B/C_5,6 inversion
Pn600	JPOS0 Position pulse in point to point control	Immediately	P	The two parameters are used in combination, and the algebraic sum of them is the position JPOS0 needs to reach.(Thenumber of servomotor rotation revolutions is related with the programme mode of point to point control.) Pn600 Unit: 10000P Pn601 Unit: 1P
Pn601	JPOS0 Position pulse in point to point control	Immediately	P	
			The meaning of other point to point control related parameters are the same.
Pn630	JPOS15 Position pulse in point to point control	Immediately	P	The two parameters are used in combination, and the algebraic sum of them is the position of JPOS0 needs to reach.(The number of servomotor rotation revolutions is related with the programme mode of point to point control.)
Pn631	JPOS15 Position pulse in point to point control	Immediately	P	
Pn632	JPOS0 Point to point speed control	Immediately	P	JPOS0 Point to point speed control Unit: rpm
			The speed of other point to point control
Pn647	JPOS15 Point to point speed control	Immediately	P	The speed of JPOS15 point to point control Unit: rpm
Pn648	JPOS0 Point to point 1st orderfilter	Immediately	P	1st order filter time of JPOS0 point to point control can stop or start the servomotor mildly.
			1st order filter of other point to point control.
Pn663	JPOS15 Point to point 1st orderfilter	Immediately	P	1st order filter time of JPOS15 point to point control can stop or start the servomotor mildly.
Pn664	JPOS0 point to point control stop time	Immediately	P	JPOS0 point to point control stop time Unit: 50ms
			Other point to point control stop time
Pn679	JPOS15 point to point control stop time	Immediately	P	JPOS15 point to point control stop time Unit: 50ms
Pn680	Reserved	—	—	—
Pn681	Hex	Immediately	P	Pn681.0 Single/cyclic, start/reference point selection [0] Cyclic operation, PCL start signal, NCL search reference point in forward direction. [1] Single operation, PCL start signal, NCL search

Parameter No.	Description	Setting Validation	Control Mode	Function and Meaning
				<p>reference point in forward direction.</p> <p>[2] Cyclic operation, NCL start operation, PCL search reference point in forward direction.</p> <p>[3] Single operation, NCL start operation, PCL search reference point in forward direction.</p> <p>Pn681.1 Change step and start mode</p> <p>[0] Delay to change step, no need of start signal, delay to start after S-ON.</p> <p>[1] PCON change step, no need of start signal, PCON delay to start after S-ON, but inside pulse can not stop when PCON off.</p> <p>[2] Delay to change step, need start signal, canceling start signal can immediately stop inside pulse.</p> <p>Return to programme start point process step when reset.</p> <p>[3] PCON change step, need start signal, canceling start signal can immediately stop inside pulse. Return to programme start point process step when reset.</p> <p>Pn681.2 Change step input signal mode</p> <p>[0] Change step input signal electrical level mode</p> <p>[1] Change step input signal pulse mode</p> <p>Pn681.3 Reserved</p>
Pn682	Programme mode	Immediately	P	<p>[0] : Incremental programme</p> <p>[1]: Absolute programme</p>
Pn683	Programme start step	Immediately	P	Select the start point of the point to point control
Pn684	Programme stop step	Immediately	P	Select the stop point of the point to point control.
Pn685	Search travel speed in position control (contact reference); Speed of finding reference point (Hitting the origin signal ORG) in position homing control.	Immediately	P	Search the servomotor speed in the direction of reference point towards travel switch.
Pn686	Leave travel switch speed in position control (contact reference); Speed of finding reference point (Leaving the origin signal ORG) in position homing control.	Immediately	P	Search the servomotor speed when the reference point leaves travel switch.

Parameter No.	Description	Setting Validation	Control Mode	Function and Meaning
Pn687	Position teaching pulse	Immediately	P	The two parameters are used in combination, and the algebraic sum of them is the current position of position teaching. When performing the position teaching by utility function, the algebraic sum of the two parameters are given to the current position Pn687 unit: 10000P Pn688 unit: 1P
Pn688	Position teaching pulse	Immediately	P	
Pn689	Homing Mode Setting	Immediately	P	<p>Pn689.0 Homing Mode [0]Homing in the forward direction [1]Homing in the reverse direction</p> <p>Pn689.1 Search C-Pulse Mode [0]Return to search C-Pulse when homing [1]Directly search C-Pulse when homing</p> <p>Pn689.2 Homing trigger starting mode [0]Homing function disabled [1]Homing triggered by SHOM signal (rising edge)</p> <p>Pn689.3 Reserved</p>
Pn690	Number of error pulses during homing	Immediately	P	unit: 10000P
Pn691	Number of error pulses during homing	Immediately	P	unit: 1P
Pn700	Hex	After restart	ALL	<p>Pn700.0 MODBUScommunication baud rate [0] 4800bps [1] 9600bps [2] 19200bps [3] 38400bps [4] 57600bps [5] 115200bps</p> <p>Pn700.1 MODBUS protocol selection [0] 7, N, 2 (MODBUS,ASCII) [1] 7, E, 1 (MODBUS,ASCII) [2] 7, O, 1 (MODBUS,ASCII) [3] 8, N, 2 (MODBUS,ASCII) [4] 8, E, 1 (MODBUS,ASCII) [5] 8, O, 1 (MODBUS,ASCII) [6] 8, N, 2 (MODBUS,RTU) [7] 8, E, 1 (MODBUS,RTU) [8] 8, O, 1 (MODBUS,RTU)</p> <p>Pn700.2 Reserved Pn700.3 Reserved</p>
Pn701	MODBUSAxis address	After restart	ALL	Axis address of MODBUS protocol communication
Pn702	Reserved	—	—	—
Pn703	CANcommunication speed	After restart	ALL	<p>Pn703.0 CAN communication baud rate [0] 50Kbps [1] 100Kbps</p>

Parameter No.	Description	Setting Validation	Control Mode	Function and Meaning
				[2] 125Kbps [3] 250Kbps [4] 500Kbps [5] 1Mbps Pn703.1 Reseved Pn703.2 Reseved Pn703.3 Reseved
Pn704	CAN communication contact	After restart	ALL	CANopen Aix address of communication
Pn840	Hex	After restart	ALL	Pn840.0 Encoder model selection [6] Wire-saving incremental encoder Pn840.1 Reserved (For factory using) Pn840.2 Power level_of Machine <u>[0] 200W</u> <u>[1] 400W</u> <u>[2] 750W</u> <u>[3] 1000W</u> [0] 400w [1] 750w [2] 1Kw Pn840.3 Reserved (For factory using)

Appendix B

Alarm Display

Alarm Display	Alarm Output	Alarm Name	Meaning
A. 01	×	Parameter breakdown	The checksum results of parameters are abnormal.
A. 03	×	Overspeed	The servomotor speed is excessively high and the servomotor is out of control.
A. 04	×	Overload	The servomotor is operating continuously under a torque largely exceeding ratings.
A. 05	×	Position error counteroverflow	Internal counter overflow
A. 06	×	Position error pulse overflow	Position error pulse exceededparameter (Pn504)
A. 07	×	The setting of electronic gear or given pulse frequency is not reasonable.	The setting of electronic gear is not reasonable or the given pulse frequency is too high.
A. 08	×	The 1st channel of current detection is wrong.	Something wrong with the inside chip of the 1st channel.
A. 09	×	The 2nd channel of current detection is wrong.	Something wrong with the inside chip of the 2nd channel.
A. 10	×	Incremental Encoder is break off.	At least one of Incremental Encoder PA,PB,PC is broken off.
A. 12	×	Overcurrent	An overcurrent flowed through the IPM.
A. 13	×	Overvoltage	Main circuit voltage for servomotor rotation is excessively high.
A. 14	×	Undervoltage	Main circuit voltage for servomotor rotation is excessively low.
A. 15	×	Bleeder resistor error	Bleeder resistor is faulty.
A. 16	×	Regeneration error	Regenerative circuit error
A. 20	×	Power line phase shortage	One phase does not bring into main circuit power supply.
A. 42	×	Servomotor type error	The parameter setting of servo drive does not match the servomotor.
A. 66	×	CAN communication abnormal	CAN communication is faulty because of abnormal communication connection or disturbance.
A. 67	×	Receiving heartbeat timeout	The master station sends heartbeat time timeout
A. 68	×	CAN Synchronization frame interval is too short	The filling time and the cycle of the synchronous frame does not match or communication is faulty.
A. 69	×	CAN Synchronization frame interval is too long	The filling time and the cycle of the synchronous frame does not match or communication is faulty.

Alarm Display	Alarm Output	Alarm Name	Meaning
A. 00	○	Not an error	Normal operation status.

○: Output transistor is ON. ✕: Output transistor is OFF.

A.45、A.46、A.47、A.48、A.51 only can be reset when the absolute encoder related alarm is cleared.

The multiturn data should be cleared because of the multiturn information is incorrect.



ESTUN AUTOMATION TECHNOLOGY CO., LTD

Address: 16 Shuige Road, Jiangning Development Zone
Nanjing 211106, P.R.China

Tel: +86-25-58328505/8507

Fax: +86-25-58328504

Web: www.estun.cn

E-mail: export@estun.com



www.estun.cn

ESTUN