

| REVISIONS |                     |         |          |
|-----------|---------------------|---------|----------|
| REV.      | DESCRIPTION         | DATE    | APPROVED |
| A         | CHANGED MOTOR CHART | 7-23-19 | JP       |

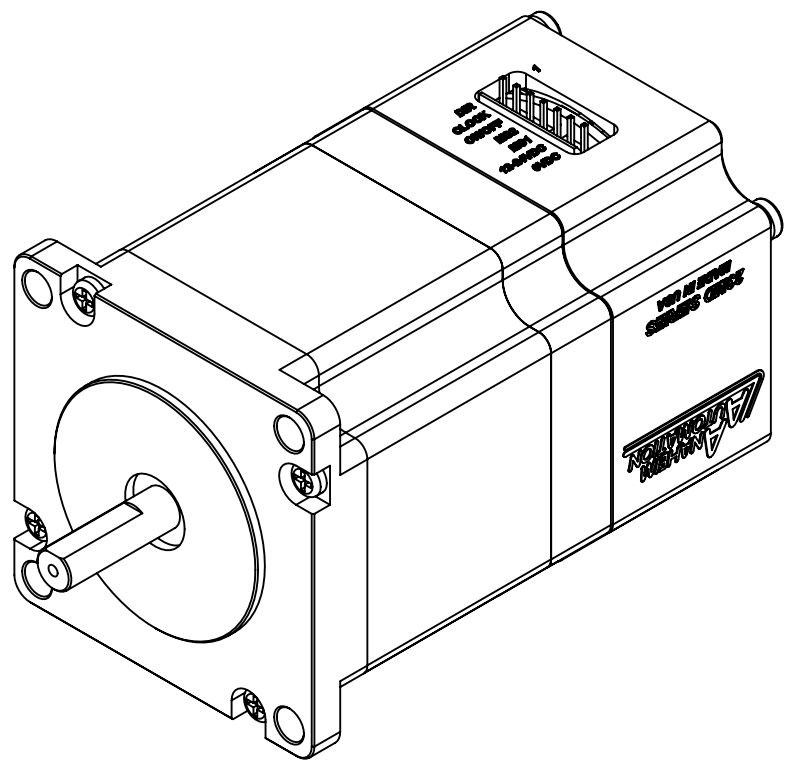
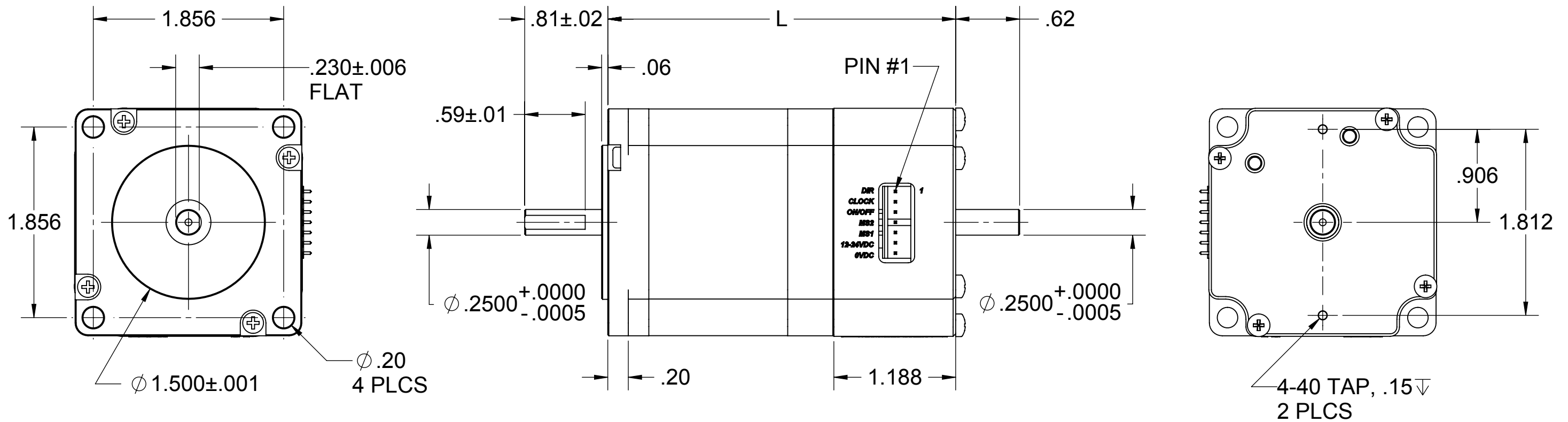

| MODEL             | LENGTH (L) |
|-------------------|------------|
| 23MD006D-00-00-00 | 2.88       |
| 23MD006D-00-24-00 | 2.88       |
| 23MD106D-00-00-00 | 3.32       |
| 23MD106D-00-24-00 | 3.32       |
| 23MD206D-00-00-00 | 4.23       |
| 23MD206D-00-24-00 | 4.23       |
| 23MD306D-00-00-00 | 5.23       |
| 23MD306D-00-24-00 | 5.23       |

**PROPRIETARY AND CONFIDENTIAL**  
 THE INFORMATION CONTAINED IN THIS DRAWING IS THE SOLE PROPERTY OF ANAHEIM AUTOMATION INC. ANY REPRODUCTION IN PART OR AS A WHOLE WITHOUT THE WRITTEN PERMISSION OF ANAHEIM AUTOMATION INC. IS PROHIBITED.

|  |         |                      |      |  |               |         |
|--|---------|----------------------|------|--|---------------|---------|
| <b>ANAHEIM AUTOMATION INC, 910 E. ORANGEFAIR LANE<br/>ANAHEIM, CA 92801 (714) 992-6990</b>                     |         |                      |      |  |               |         |
| UNLESS OTHERWISE SPECIFIED:  |         | NAME                 | DATE | TITLE:<br><b>SPEC DRAWING, DIMENSIONS<br/>23MDX06D W/O ENCODER</b> |               |         |
| DIMENSIONS ARE IN INCHES   |         | DRAWN                | TDR  |  |               | 7-30-19 |
| TOLERANCES:<br>FRACTIONAL ±<br>ANGULAR: MACH ± BEND ±<br>TWO PLACE DECIMAL ± .01<br>THREE PLACE DECIMAL ± .005 |         | CHECKED              |      |  |               |         |
| INTERPRET GEOMETRIC TOLERANCING PER:   |         | ENG APPR.            |      |  |               |         |
| MATERIAL   |         | MFG APPR.            |      |  | Q.A.          |         |
| FINISH   |         | COMMENTS:            |      |  |               |         |
| NEXT ASSY  | USED ON |                      |      | SIZE   | DWG. NO.      |         |
| APPLICATION  |         | DO NOT SCALE DRAWING |      | <b>B</b>   | <b>AA6013</b> |         |
|  |         |                      |      | SCALE: 1:1   | WEIGHT:       |         |
|  |         |                      |      | REV <b>A</b>   |               |         |
|  |         |                      |      | SHEET 1 OF 1   |               |         |