

BRK-20H-480-024-xxx Motor Friction Brake



FEATURES

- **Perfect for Holding Applications**
- **Handles High Torque**
- **Compact Size**
- **Operates On Low Voltage**



DESCRIPTION

Perfect for holding applications, these friction brakes can handle high torque with a compact size. The low voltage design will operate on applications susceptible to weak battery, brown out or long wiring runs. When the electric power is applied, the armature is pulled by the electromagnetic force in the magnet body assembly, which overcomes the spring action. This allows the friction disc to rotate freely. When electrical power is interrupted, the electromagnetic force is removed and the pressure spring mechanically forces the armature plate to clamp the friction disc between itself and the pressure plate. This develops torque to hold the load.

SPECIFICATIONS

Model #	Fits NEMA Size	Bore Size (in)	Maximum Torque (oz-in)	Maximum Torque (in-lb)	Electric Power (Watts)	Current (mA)	Voltage (V)	Diameter (in)	Width (in)	Weight (lbs)
BRK-20H-480-024-250	34	0.250	480	30	12.5	521	24	2.52	1.190	1.06
BRK-20H-480-024-375	34	0.375	480	30	12.5	521	24	2.52	1.190	1.06
BRK-20H-480-024-500	34	0.500	480	30	12.5	521	24	2.52	1.190	1.06

*Brakes may be purchased as adders assembled to Anaheim Automation motors. Please contact us for assistance.

L010463

Brake

DIMENSIONS

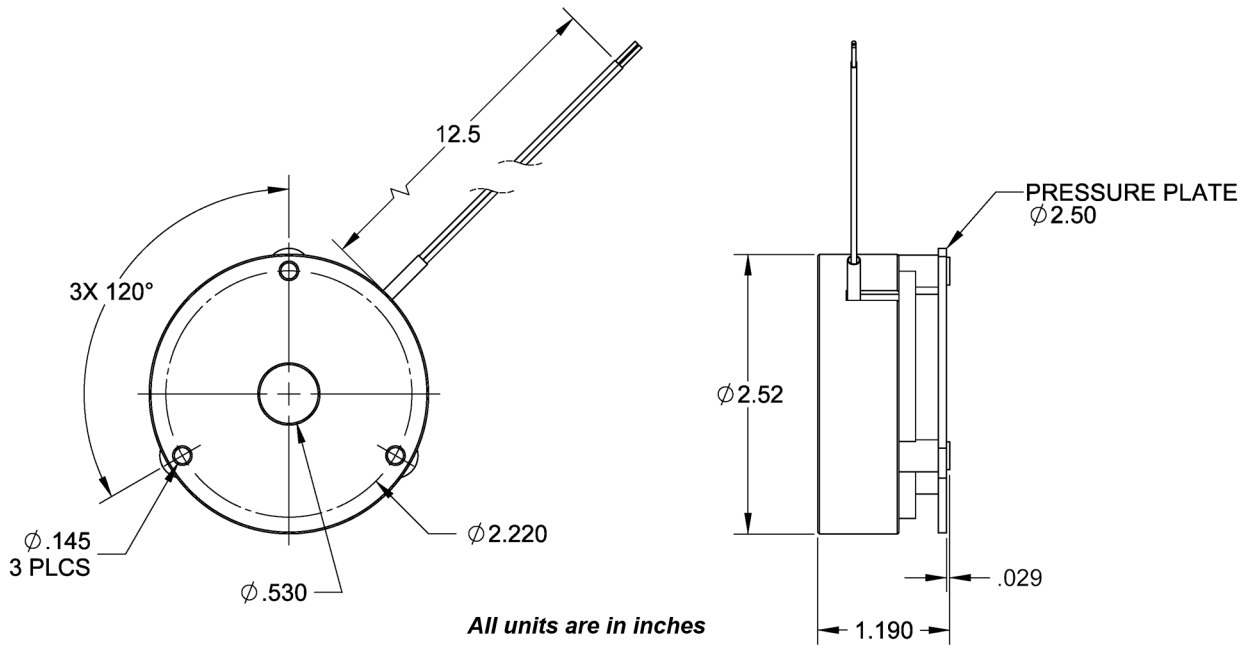

KEYWAY SIZES

Bore Size	Keyway Size	
	Width	Depth
0.2500	1/16	1/32
0.3125	1/16	1/32
0.3750	3/32	3/64
0.5000	1/8	1/16
5 mm	2 mm	1 mm
6 mm	2 mm	1 mm
7 mm	2 mm	1 mm
8 mm	2 mm	1 mm
9 mm	3 mm	1.4 mm
10 mm	3 mm	1.4 mm
11 mm	4 mm	1.8 mm
12 mm	4 mm	1.8 mm

Note: For half inch bore size; set screws are located 120 degrees from keyway.