

BDA-56C-100 - Permanent Magnet DC Motors



FEATURES

- DC Brush Motor
- Designed for High Torque Brush Applications
- Provides Constant Torque at Various Speeds
- Up to 576 oz-in of Torque
- NEMA Frame Size 56C
- Body Diameter 123mm



DESCRIPTION

The 56C Frame DC motors provide a cost-effective solution for your application. The BDA-56C-100 can be used anywhere from power pulleys, belts, pumps to water heating and other machine applications. The BDA-56C-100 has strong permanent magnets to provide the torque you need. The BDA-56C-100 1HP motor can provide up to 576 oz-in of torque. Cooling vents on the motor casing are placed optimally for internal cooling of the motor.

DIMENSIONS

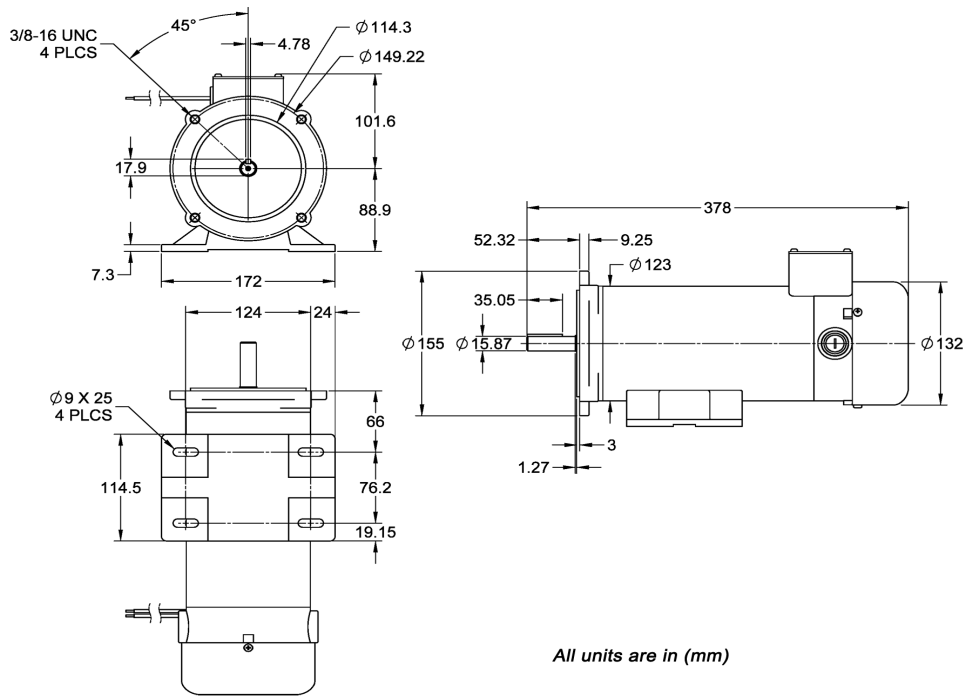

SPECIFICATIONS

Model #	Armature Voltage (V)	No Load Speed (RPM)	Current (A)	Power (W)	Torque (oz-in)	Body Diameter (mm)	Pilot Diameter (mm)	Pilot Depth (mm)	Shaft Length (mm)	Shaft Diameter (mm)	Motor Length (mm)
BDA-56C-100-90V-1800	90	1800	10	746	576	123	114.47	2.77	51.67	15.93	323
BDA-56C-100-180V-1800	180	1800	5.4	746	576	123	114.47	2.95	51.17	15.83	323

L010639

Important Notes: The information provided herein was known to be accurate upon publication; however, specifications can be changed over time, and most likely will vary between manufactures. Some of these differences are substantial. Therefore, a customer must verify all critical parameters of an application before selecting a product.

This **Cross Reference List** is offered to assist the customer in choosing Anaheim Automation's products. However, any selection, quotation, or suggestion for any product, offered from Anaheim Automation's staff, its' representatives or distributors, are only to assist the customer. In all cases, *determination of fitness of the product in a specific system application is solely the customers' responsibility.* While every effort is made to offer solid advice, and to produce technical data and illustrations accurately, such advice and documents are for reference only. Anaheim Automation is in no event liable for indirect or consequential damages resulting from the use or application of any product. *Improper use can result in personal injury or death, property damage, and/or economic loss.*

Experimentation: Tailoring

Please be advised that experimentation is almost always necessary for motion control components because of dynamic changes in system friction and inertia, (load anomalies) that may be difficult to calculate. For example, a stepper motor resonance effects can also change when the stepper motor is coupled to its load. At Anaheim Automation, we encourage customers to experiment with several options for optimal system performance.