

A6 Assembly Instructions for Shaft ≤ 0.394 " (10mm)

Step 1: Base Mounting

Place encoder base onto mounting surface. Slip centering tool over the shaft and into the center hole of the base. While holding pressure on the centering tool, tighten mounting screws. Remove centering tool.



Step 2: Codewheel Installation

Place spacer tool around shaft. Slip hubdisk assembly onto shaft and slide down until it bottoms out against spacer tool.

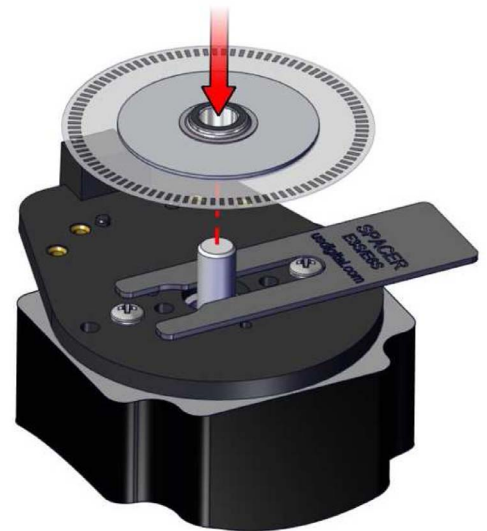

Step 3: Securing the Codewheel

Tighten Set Screw with Hex Wrench while pressing down on hub. Remove spacer tool.

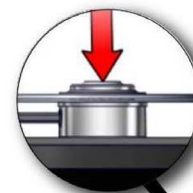

Hub Set Screw
2 – 3 in-lbs torque

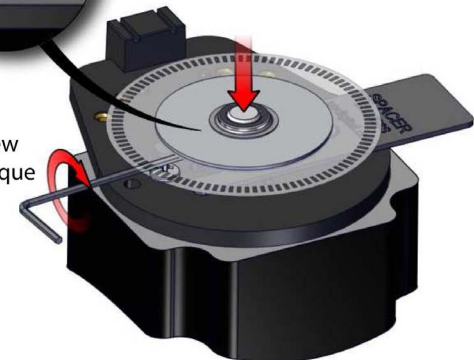

L011737

Step 4: Encoder Module Installation

Slip the optical encoder module into position until the two assignment pins slip into the holes of the module. The pins should be on the top of the module facing out. Secure the encoder module to the base with the two 4-40 x 1/2" pan head screws which are supplied with the kit.

Differential Version Only:

Press line driver onto module pins until it reaches the end of its motion. Caution! To avoid injury make sure that the line driver is held properly (as shown) during installation, module pins are sharp!

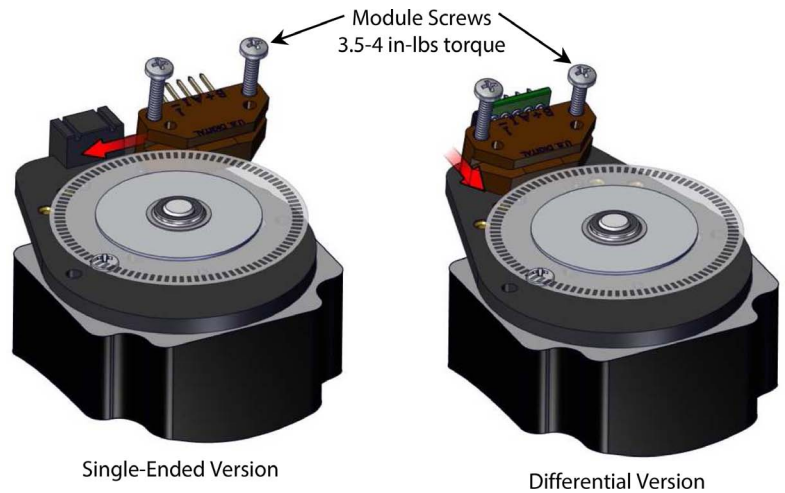
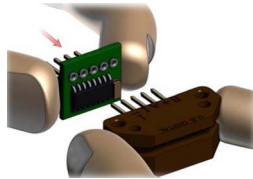

Single-Ended Version

Differential Version

Step 5: Cover Installation

Place the cover over the assembly and secure the components in place with two 4-40 x 5/8" flat head screws supplied with the kit.

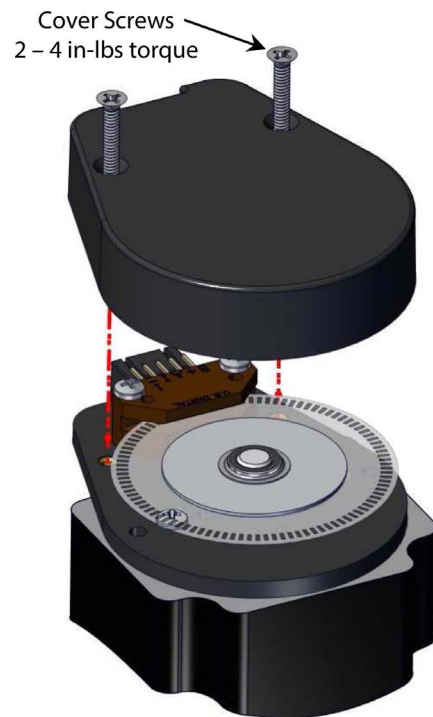

A6 Assembly Instructions for Shaft > 0.394" (10mm)

Step 1: Base Mounting

Place encoder base onto mounting surface. Slip centering tool over the shaft and into the center hole of the base. While holding pressure on the centering tool, tighten mounting screws. Remove centering tool.

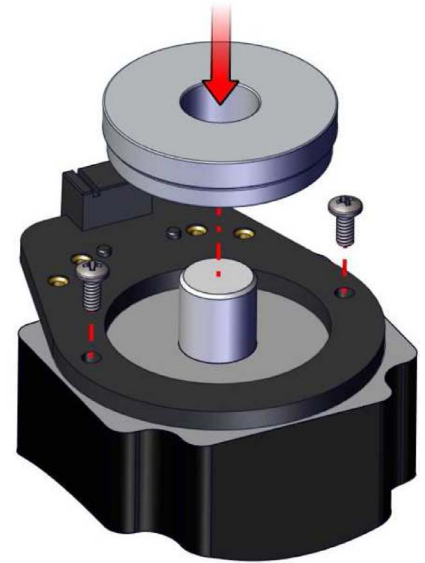

Step 2: Codewheel Installation

Push the spacer tool onto the bottom section of the hubdisk assembly. Slip hubdisk assembly onto shaft and slide down until spacer tool bottoms out against encoder base.

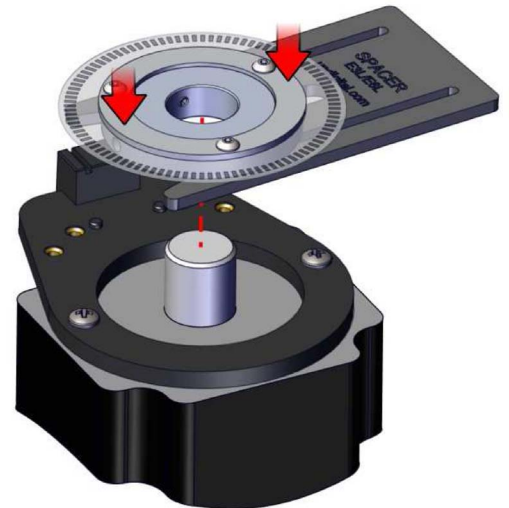

Step 3: Securing the Codewheel

Tighten Set Screw with Hex Wrench while pressing down on hub. Remove spacer tool.

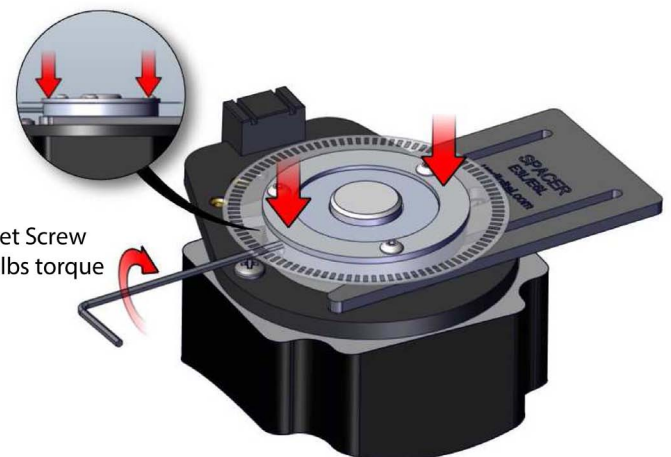

Hub Set Screw
2 – 3 in-lbs torque

L011737

Step 4: Encoder Module Installation

Slip the optical encoder module into position until the two assignment pins slip into the holes of the module. The pins should be on the top of the module facing out. Secure the encoder module to the base with the two 4-40 x 1/2" pan head screws which are supplied with the kit.

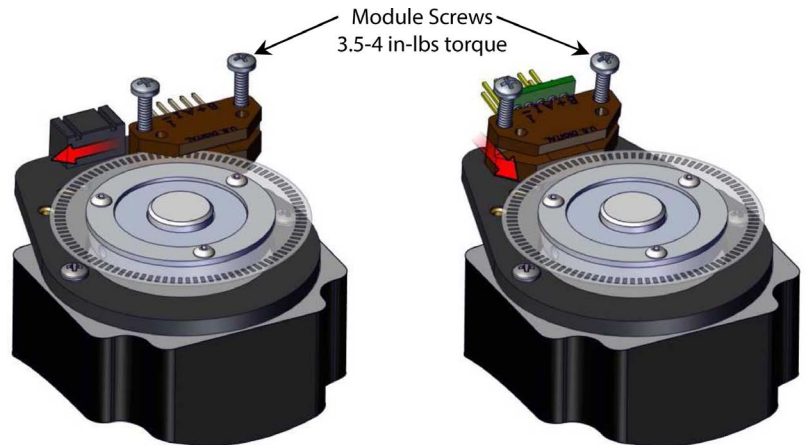

Single-Ended Version

Differential Version

Differential Version Only:

Press line driver onto module pins until it reaches the end of its motion. Caution! To avoid injury make sure that the line driver is held properly (as shown) during installation, module pins are sharp!

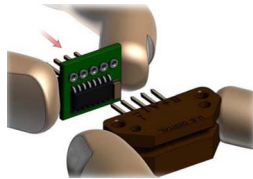

Step 5: Cover Installation

Place the cover over the assembly and secure the components in place with two 4-40 x 5/8" flat head screws supplied with the kit.

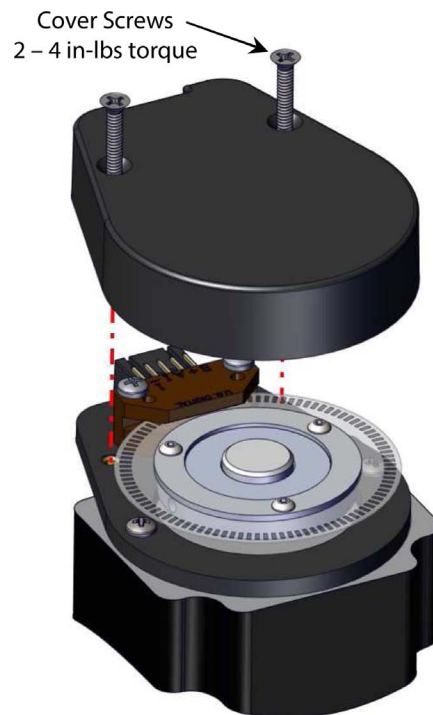

Parameter	Torque
Hub Set Screw to Shaft	2-3 in-lbs
Cover (4-40 Screw Through Cover Into Base)	2-4 in-lbs
Base to Mounting Surface	4-6 in-lbs
Base to Mounting Adapter Plate	4-6 in-lbs
Adapter Plate to Mounting Surface	4-6 in-lbs
Module to Base	3.5-4 in-lbs