

PRONET-10AEA-EC



FEATURES

- **Power Rating of 1000 Watts**
- **100 BASE-TXI Twisted-Pair Wire, 100 BASE-FX Fiber, or LVDS (Low Voltage Differential Signaling)**
- **Supports Topologies - Line Type, Tree Type and Star Type**
- **Open Network Based on Ethernet**
- **Capable of Updating the Information of 1000 I/O**
- **Exchange of Frame as Big as 1486 Bytes**



DESCRIPTION

The EtherCAT is an open network based on Ethernet to achieve real time control. It is capable of supporting high speed and synchronized control. The efficient network topology allows the network structure with too many concentrator and complicated connections to be avoided. It's suited for protocol in motion control and factory automation applications. With the EtherCAT slave device it can read the data marked with the devices address information when the frame passes this device. Some data will be written into the when it passes this device. Because of this data reading and data writing could be done within several nanoseconds.

DIMENSIONS

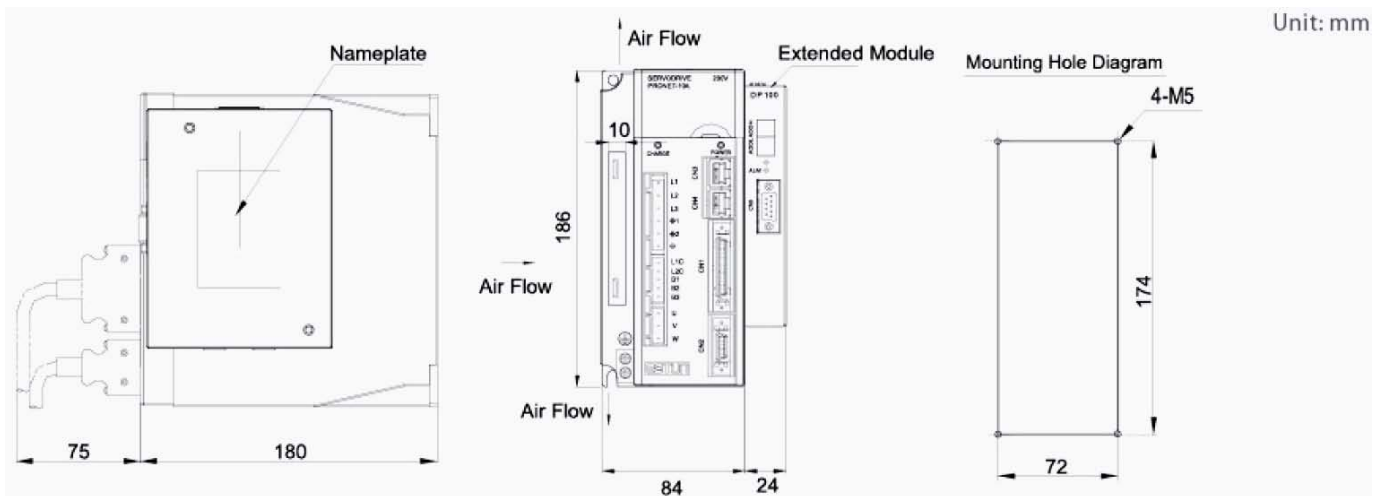

Item	Rated Power (Watts)	Rated Voltage	Drive Control Capabilities	COMM	I/O Signals
PRONET-10AEA-EC	1000	200VAC	Position, Speed, Torque	EtherCAT	5 Inputs 3 Outputs

L011475

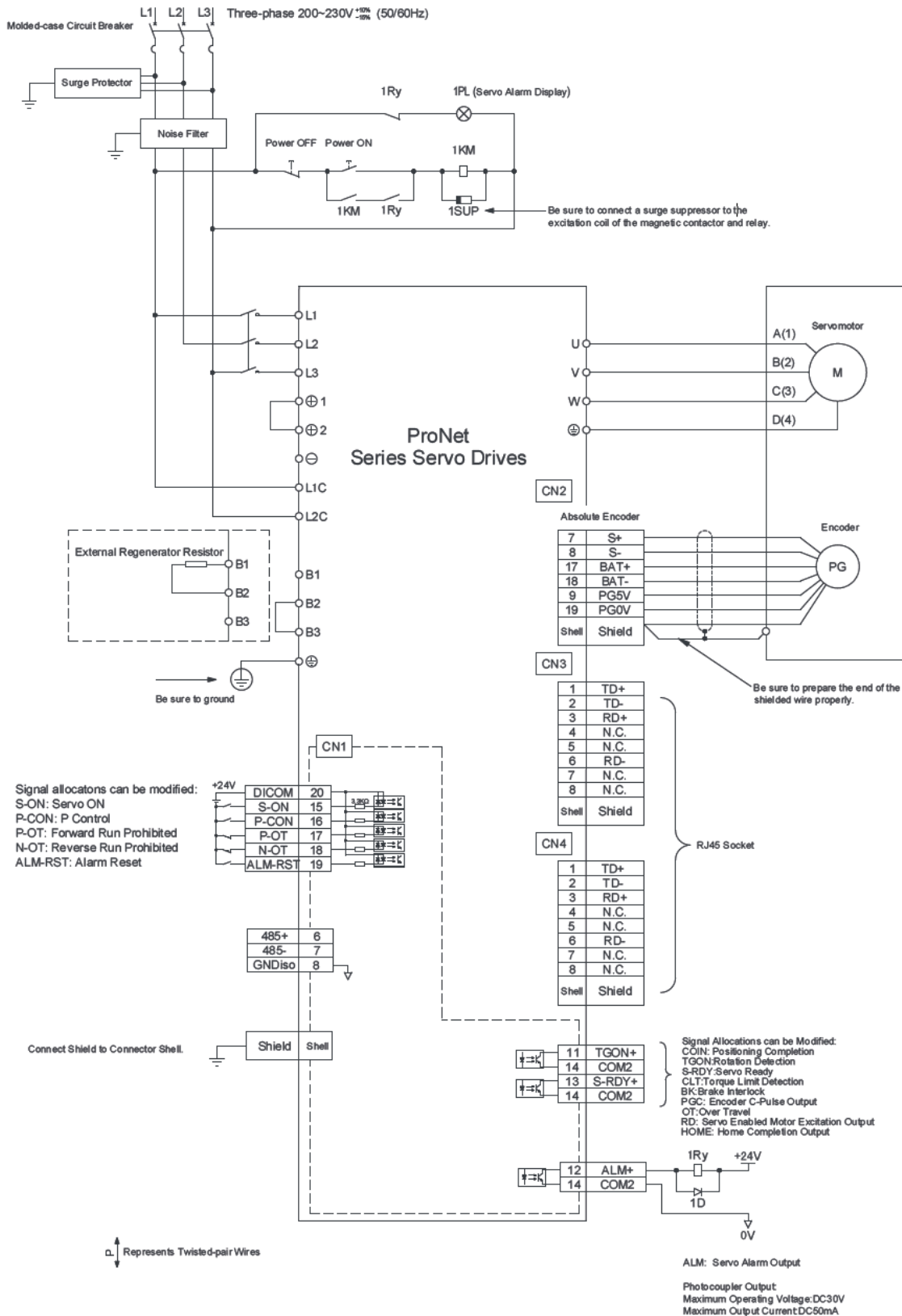

L011475

Compatible Motors

Part Number	Description
EMJ-10ASB22	Servo Motor
EMJ-10ASB24	Servo Motor w/Holding Brake

Compatible Cables

Part Number	Description
PDM-JE18-05	Power Cable
PAP-JE24-05	Encoder Cable

L011475