

BLHP101 HIGH PERFORMANCE BILEVEL STEP MOTOR DRIVER

- Very High Motor Power Output
- 15 Amperes/phase Maximum Operating Current
- 10 Amperes/phase Standstill motor current
- High Start-Stop Speeds
- Transient Voltage Suppression
- Half-step and Full-step Operation
- Bilevel Drive Operation (No RFI or EMI problems)
- TTL/CMOS Compatible Inputs
- Clock and Direction or Dual Clock Operation
- Motor Turn-off Input
- +5VDC Output

GENERAL DESCRIPTION

The Anaheim Automation BLHP101 step motor driver is designed for motor applications that require very high power output and high start-stop step rates. Outstanding motor performance is achieved by means of an enhanced bilevel or dual-voltage drive technique. This driver may be used with six or eight lead, frame size 34 and 42 step motors whose phase current ratings range from 2 to 12.5 amperes per phase. This driver requires a dual-voltage power supply and a logic power supply.

BILEVEL DRIVE

The basic function of a step motor driver is to control the motor winding currents. Motor performance is determined by how fast the driver can increase and decrease the winding currents. A rapid rise in winding current is achieved by applying a high voltage directly to a motor winding. This rapid rise of current is also referred to as the "kick" or operating current. When a desired current level is reached, the high voltage is turned off and a low voltage is applied to maintain a suitable holding current level. When a motor winding is turned off, a rapid decrease in winding current is achieved by routing the energy in the collapsing field back to the power supply through a high voltage path. The high voltage supply

furnishes the energy necessary to maintain motor output torque at high step rates thus providing high mechanical power output. The low voltage supply provides much of the current needed at low step rates and all of the holding current.

Bilevel drivers do not use high frequency switching techniques as chopper drivers do. Consequently, they do not create the EMI, RFI, and motor heating problems that are associated with chopper drivers.

TRANSIENT VOLTAGE SUPPRESSION

Transient Voltage Suppression (TVS) Diodes on the motor phase outputs allow for much longer motor cables to be used. Normally when using long motor cables, voltage transients and spikes are created. These transients often exceed the voltage ratings of the output phase transistors, resulting in blown transistors. The addition of the TVS Diodes suppresses these transients and protect the transistors against damage.

CLOCK AND DIRECTION/ CCW OPERATION

BLHP101 drivers are shipped from the factory with terminals 6 and 5 assigned as CLOCK and DIRECTION inputs

respectively. Pulses applied to the CLOCK input cause the motor to step in the clockwise direction if the DIRECTION input is at a logic "1" (or No connection), or in the counterclockwise direction if the DIRECTION input is at a logic "0". By setting JP1 to the "1-2" position, terminal 5 becomes the CCW (Counterclockwise Clock) input. Pulses applied to the CCW input cause the motor to step in the counterclockwise direction. Either positive or negative going pulses may be used by setting JP3 to the appropriate position. See Figure 1 and Table 1 for Jumper locations and settings.

MODE SELECT/+5V OUTPUT

BLHP101 drivers are shipped from the factory with terminal 9 assigned as an excitation Mode Select input. The Mode Select input is used to select either half-step or full-step motor operation. Half-step operation is generally preferred because this mode provides better resolution, minimizes resonance effects, and reduces power consumption. The motor steps in increments of half the natural step angle, e.g. in 0.9 degree steps for a 1.8 degree step motor. In full-step operation, the motor steps in 1.8 degree steps. By setting JP2 to the "1-2" position, terminal 9 becomes a +5VDC

A N A H E I M A U T O M A T I O N

#L010014



910 E. Orangefair Lane, Anaheim, CA 92801
(714) 992-6990 • FAX: (714) 992-0471

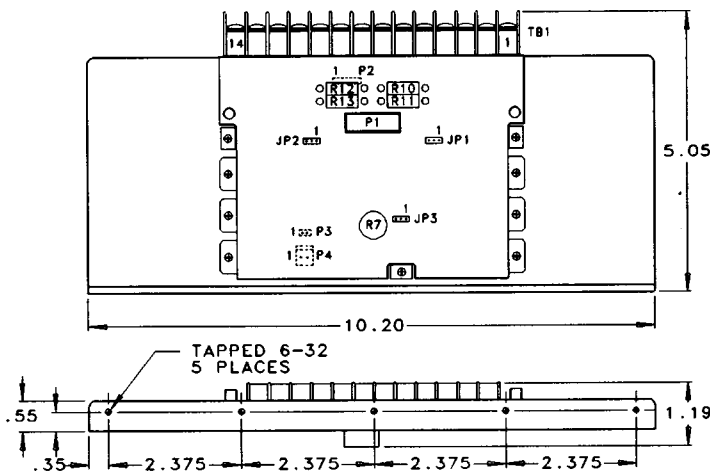

FIGURE 1: Dimensions.

JUMPER DESCRIPTION	JP1	JP2	JP3
TERMINAL 5 = DIRECTION	2-3	X	X
TERMINAL 5 = CCW	1-2	X	X
TERMINAL 9 = HS/FS	X	2-3	X
TERMINAL 9 = +5VDC OUTPUT	X	1-2	X
POSITIVE GOING CLOCK INPUTS	X	X	2-3
NEGATIVE GOING CLOCK INPUTS	X	X	1-2
STANDARD PRODUCT (READY TO SHIP)	2-3	2-3	2-3

TABLE 1: Jumper Description.

X=DON'T CARE

regulated output. The driver defaults to half-step when the +5VDC output is used.

MOTOR ON/OFF INPUT

This input can be used to turn off all four motor phases (de-energize the motor) in applications where motor detent torque is sufficient to maintain the load position. This feature can be used to reduce the load on the power supply and the heat dissipation in the driver circuitry and motor. Terminal 10 is the MOTOR ON/OFF Input.

VERIFYING CORRECT STANDSTILL CURRENT

Verify that the V_{lv} supply provides adequate motor holding current as follows:

1. Place jumper JP2 in the "2-3" position (Mode Select).
2. Connect the Mode Select Input to 0VDC (Fullstep).
3. Measure the voltage across resistors R12 and R13.
4. Multiply each of the voltage reading obtained above by 30 to obtain the holding currents in the two energized phases.
5. Disconnect the Mode Select input from 0VDC unless fullstep operation is desired.
6. Place JP2 in the appropriate position.

Holding current values obtained above should be between 65% and 100% of the motor phase current rating. If the holding current is below 65% of rating, the motor may have trouble stopping accurately. This condition can be

corrected by using a V_{lv} supply with a higher output voltage. Holding currents greater than 100% of rating may result in excessive motor heating and will not improve motor performance. *A holding current value in the lower portion of the 65% to 100% range is preferred.*

ADJUSTING THE KICK CURRENT

The kick (or operating) current level is the desired phase current level that the high voltage provides each time a step is taken. The high voltage is turned off when this level is reached. *The kick current level should be set to approximately 1.4 times the rated phase current.* To obtain a proper setting, adjust potentiometer R7 to a value that corresponds with the rated current in Table 3. When using a motor listed in Table 4, use the recommended potentiometer setting given in the table. **WARNING:** The kick current level must be set before operating a motor.

MOTOR DRIVER CONNECTIONS

Motor wires are connected to the driver pack through terminals 1, 2, 3, 12, 13, and 14. Electrical connections to control inputs should be kept physically separated from the motor connections. *Wiring from the driver to the motor should be routed away from all other wiring.* Typical hookup diagrams are shown in Figures 2 and 3.

MOUNTING AND COOLING

The BLHP101 driver consists of a printed circuit board assembly mounted on a combination heat sink and mounting plate. The aluminum mounting plate should be mounted to a larger aluminum plate or other heat

conducting material. Cooling air must be directed at the mounting plate such that no point on the mounting plate surface exceeds a temperature of 80 degrees Celsius.

P1 HEADER CONNECTOR

This connector is used for a direct connection to Anaheim Automation standalone Indexers such as the CL2541P. The driver supplies power to the Indexer through this 14-pin connector and receives Clock, Direction, and other signals through this connector. See Table 2 for pinout.

POWER SUPPLY KIT

A Power Supply kit (PSK32050N) is available and recommended to use with the BLHP101 driver. The kit contains a 500VA transformer, diode bridges, and filter capacitors.

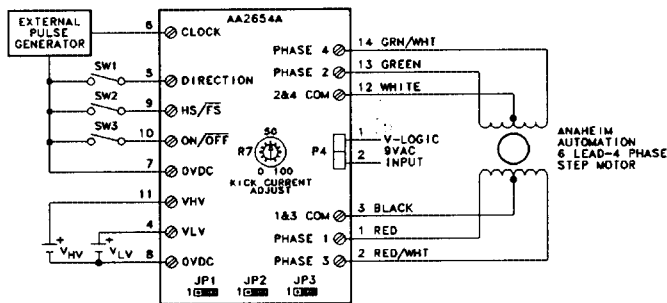

FIGURE 2: Hookup Diagram using Clock, Direction, and Mode Select.

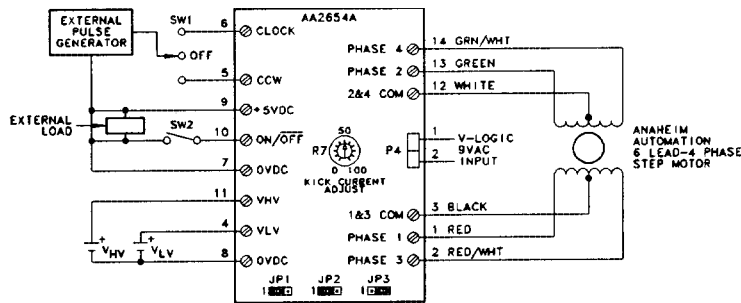

FIGURE 3: Hookup Diagram using Clock, CCW, and +5VDC Output.

SPECIFICATIONS:

POWER REQUIREMENTS

Logic Power Supply:

7-11 VAC on connector P4

Low Voltage Power Supply (Vlv):

The Vlv supply voltage can range from a minimum of 3.5VDC to a maximum of 7.0VDC. A Vlv supply voltage of 4.5VDC is used in many applications. The maximum current required from the supply is two times the motor phase current rating. The Vlv supply need not be regulated.

High Voltage Power Supply (Vhv):

The Vhv supply voltage can range from a minimum of 50VDC to a maximum of 100VDC. A Vhv of 90VDC is typically used. The current required from the Vhv supply depends upon the motor performance requirements. The Vhv supply need not be regulated.

CONTROL INPUTS

Terminals 5,6,9,10

Logic "0": 0 to 0.8 VDC.

Logic "1": 3.5 to 5 VDC.

CLOCK Input: (Terminal 6)

This input is either pulled down (for positive going pulses) or pulled up (for negative going pulses) through a 10k ohm resistor (set by JP3). A minimum pulse width of 15 microseconds is required to step the motor. The maximum control pulse rate is limited by motor performance.

DIRECTION/CCW Input: (Terminal 5)

When programmed as DIRECTION input (set by JP1), this input is internally pulled up to +5VDC through a 10k ohm resistor. When a logic "1" (or no

connection) is applied, the motor will step in the clockwise direction when pulses are applied to the CLOCK input. Similarly, when a logic "0" is applied, the motor will step in the counterclockwise direction when pulses are applied to the CLOCK input. When programmed as CCW input, the motor will step in the counterclockwise direction when pulses are applied to this input (pulse requirement is same as for CLOCK input).

MODE SELECT/+5VDC OUTPUT: (Terminal 9)

When programmed as Mode Select Input (set by JP2), this terminal is internally pulled up to +5VDC through a 10k ohm resistor. When a logic "1" (or no connection) is applied, the motor will operate in halfstep mode. When a logic "0" is applied, the motor will operate in fullstep mode. When this terminal is programmed as +5VDC Output, up to 500mA may be used (when the logic power supply is \geq 9VAC) to power up external circuitry. The driver defaults to halfstep when the +5VDC output is used.

MOTOR ON/OFF INPUT: (Terminal 10)

This terminal is internally pulled up to +5VDC through a 10k ohm resistor. When a logic "1" (or no connection) is applied, the driver phase outputs are enabled and the motor is energized. When a logic "0" is applied, the driver phase outputs are disabled and the motor is de-energized.

MOTOR PHASE OUTPUTS:

(Terminals 1,2,13,14)

These outputs can sink a peak of 15 Amperes or sink 10 Amperes

continuously and stand-off 250 VDC maximum.

MOTOR COMMON OUTPUTS:

(Terminals 3,12)

These outputs can source a peak current of 15 Amperes, or source 10 Amperes continuously.

AMBIENT TEMPERATURE:

0 to 50 degrees Celsius.

SHIPPING WEIGHT:

1 pound.

P1 Pin	Description
1	N/C
2	N/C
3	+12V UNREG.
4	N/C
5	DIRECTION
6	MOTOR ON/OFF
7	HS/FS
8	N/C
9	N/C
10	CLOCK
11	0VDC
12	N/C
13	0VDC
14	N/C

Table 2: 14-Pin Header for Indexer Interfacing.

TORQUE/SPEED CURVES

34D106 and 34D109

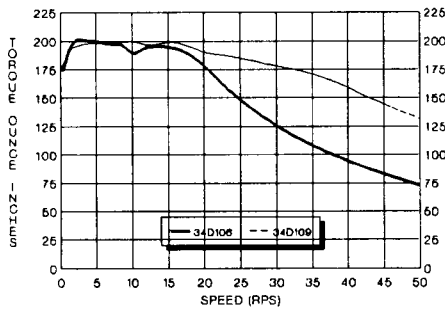

34D207, 34D209, 34D213

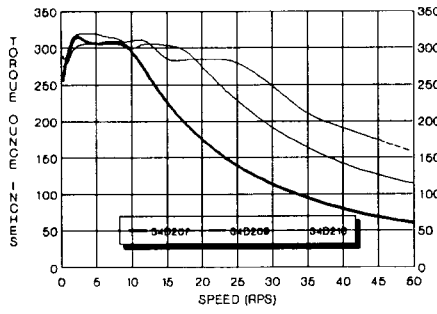

34D307, 34D311, 34D314

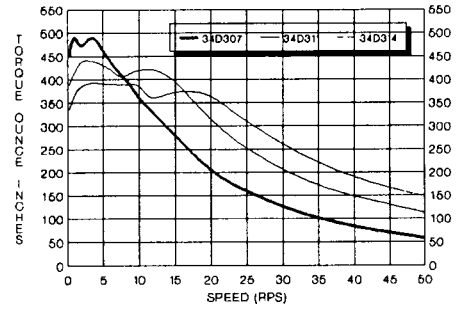

42D112 and 42D119

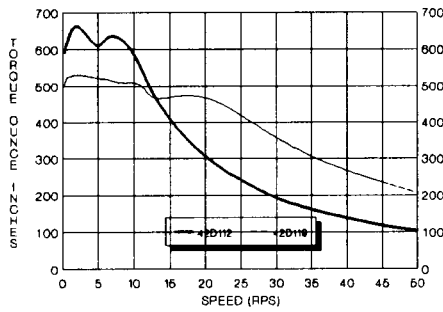

42D212, 42D219, 42D225

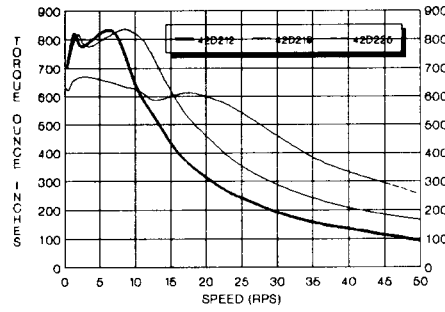

Rated Motor Phase Current	KICK CURRENT	POT SETTING
1.4 - 2.4	2.0 - 3.4	0 - 10
2.4 - 3.3	3.4 - 4.6	10 - 20
3.3 - 4.3	4.6 - 6.0	20 - 30
4.3 - 5.4	6.0 - 7.5	30 - 40
5.4 - 6.3	7.5 - 8.8	40 - 50
6.3 - 7.2	8.8 - 10.1	50 - 60
7.2 - 8.1	10.1 - 11.4	60 - 70
8.1 - 8.9	11.4 - 12.5	70 - 80
8.9 - 9.6	12.5 - 13.5	80 - 90
9.6 - 12.5	13.5 - 15.0	90 - 100

Table 3: Potentiometer Settings for Kick Current.

AA MOTOR	HOLDING CURRENT	KICK CURRENT	POT SETTING
34D106	1.95 - 3.00	4.20	17
34D109	3.12 - 4.80	6.72	35
34D207	2.28 - 3.50	4.90	22
34D209	3.00 - 4.60	6.44	33
34D213	4.23 - 6.50	9.10	53
34D307	2.28 - 3.50	4.90	22
34D311	3.58 - 5.50	7.70	42
34D314	4.55 - 7.00	9.80	58
42D112	3.97 - 6.10	8.54	48
42D119	6.18 - 9.50	13.3	88
42D212	3.97 - 6.10	8.54	48
42D219	5.98 - 9.20	12.88	84
42D225	8.25 - 10.00	15.00	100

Table 4: Holding Current and Kick Current Settings for AA Motors.



A N A H E I M A U T O M A T I O N

910 E. Orangefair Lane, Anaheim, CA 92801
(714) 992-6990 • FAX: (714) 992-0471