

## Assembly Instructions

### Step 1:

- Double check dimension size, and clean assembled flange surface of servomotor and brake.

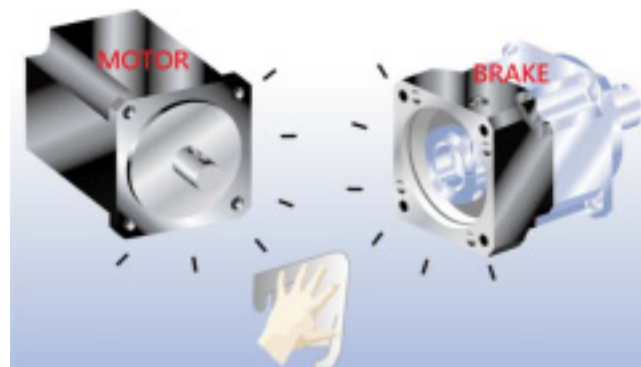

### Step 2:

- Remove Key from motor shaft (as below red circle).

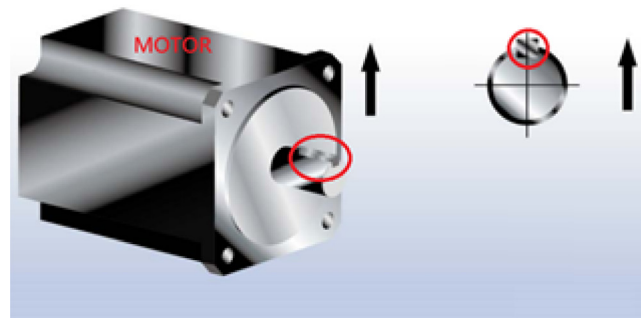

## Step 3.1:

- Put Brake at the bottom and motor at the top. Place them vertically.

## Step 3.2:

- Use wrench to tighten mounting bolts (including washer) in sequence 1~4 by 5% tighten torque to assembly brake and servomotor.

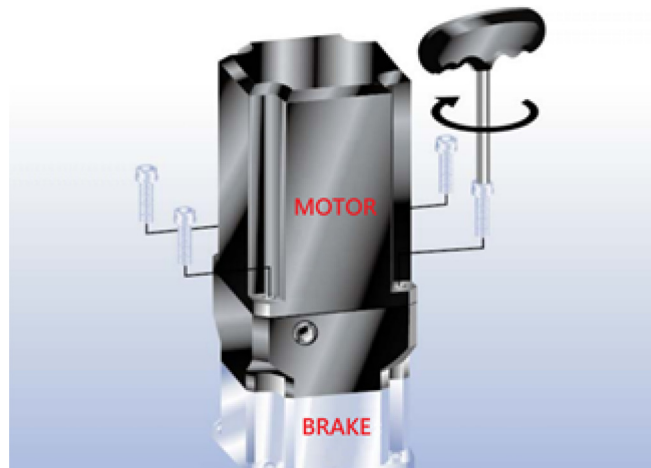

## Step 4:

- Use wrench to tighten the set collar bolt by 5% tighten torque.

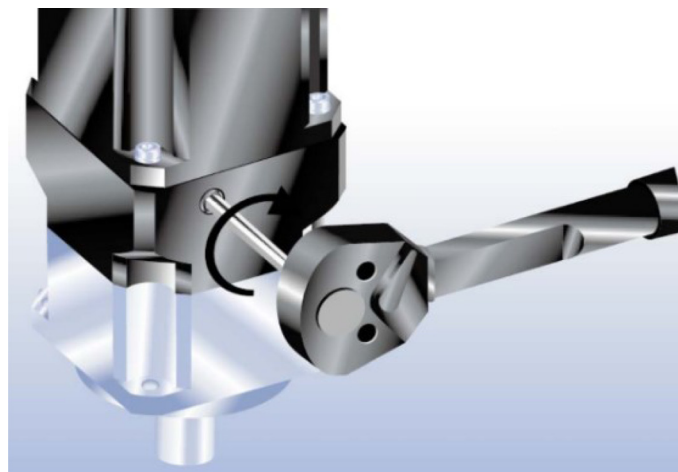

L011953

## Step 5:

- Use wrench to tighten mounting bolts (including washer) in sequence 1~4 by full tighten torque to assembly brake and servomotor.

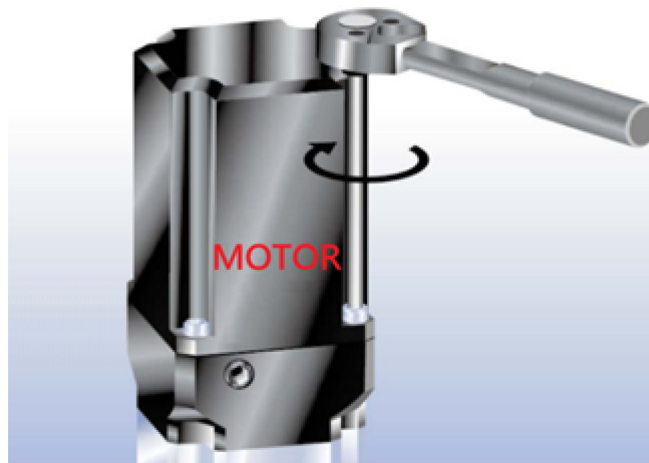

## Step 6:

- Use wrench to tighten back screw plug by full tighten torque.

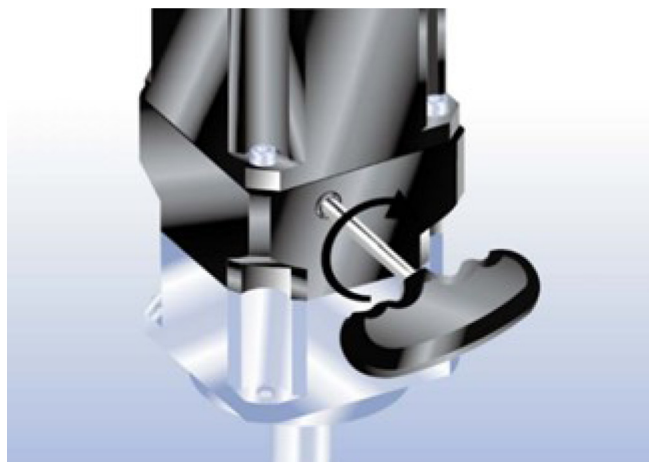

L011953