

MBDC050-050301 - DC Speed Controllers



FEATURES

- Maximum Current Limit Setting from 10.0-30.0 Amps
- Vary Speed Using an External 0-5VDC Power Supply
- 2-Quadrant Operation
- Open-Loop Velocity Mode
- Cycle-by-Cycle Over Current Protection
- Requires 20-50VDC Input
- Run/Stop, Freewheel and Direction Inputs
- Selectable Ramp Up
- TTL-CMOS Compatible Inputs



DESCRIPTION

The MBDC050-050301 is a DC Speed Controller designed to drive Brush DC Motors at currents up to 30A peak with an input voltage range of 20-50VDC. An internal potentiometer is used to set the peak motor current limit between 10.0-30.0A, and an external DC power supply ranging from 0 to 5V can be applied to vary the speed of the motor. The direction of the motor can be preset by the direction control input. When using the run/stop input, there are three ramp up profiles from standstill to select from. The run/stop input will override all other inputs into the driver. This controller features protection from over-current and under-voltage. The fault protection is set for a cycle-by-cycle motor turn-off.

DIMENSIONS

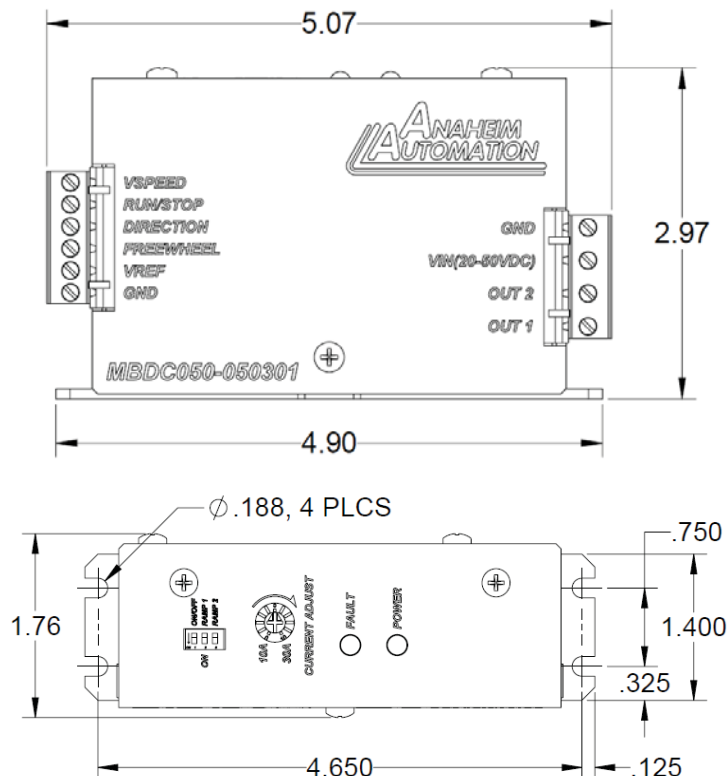

L011739

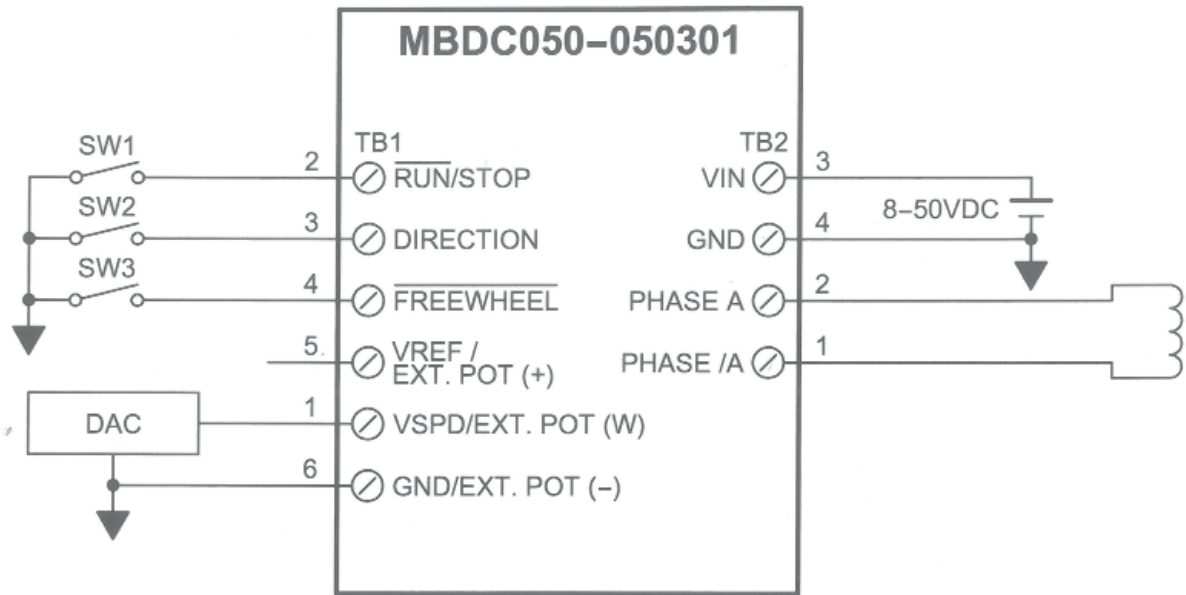

Model #	Description
MBDC050-050301	BDC Driver, 30A, 20-50V
PSA40V4A	DC Power Supply 40VDC at 4.0 Amps
PSA40V8A	DC Power Supply 40VDC at 8.0 Amps

Vspeed Control: (TB1, Pin 1):	0VDC - Motor Stopped 5VDC - Max Speed (6.25VDC max)
Control Inputs (TB1, Pins 2-4):	TTL-CMOS Compatible Logic "0" = 0-0.8VDC Logic "1" = Open
Run/Stop (TB, Pin 2):	Logic "1" (open) - Stop and if running stop rapidly Logic "0" - Running
Direction: (TB1, Pin 3):	Logic "1" (open) - Counterclockwise Logic "0" - Clockwise
Freewheel: (TB1, Pin 4):	Logic "1" (open) - Motor Enabled Logic "0" - Motor is de-energized and will coast to a stop
Vref Output: (TB1, Pin 4)	6.25V @ 30mA Maximum
Power Requirements	20VDC (min) - 50VDC (max)
Output Current Rating: (TB1)	30 amperes peak maximum operating current.
Operating Temperature:	0°C to 70°C