

MDC151-024031 Series 24V, 3A Brushless DC Controller

User's Guide

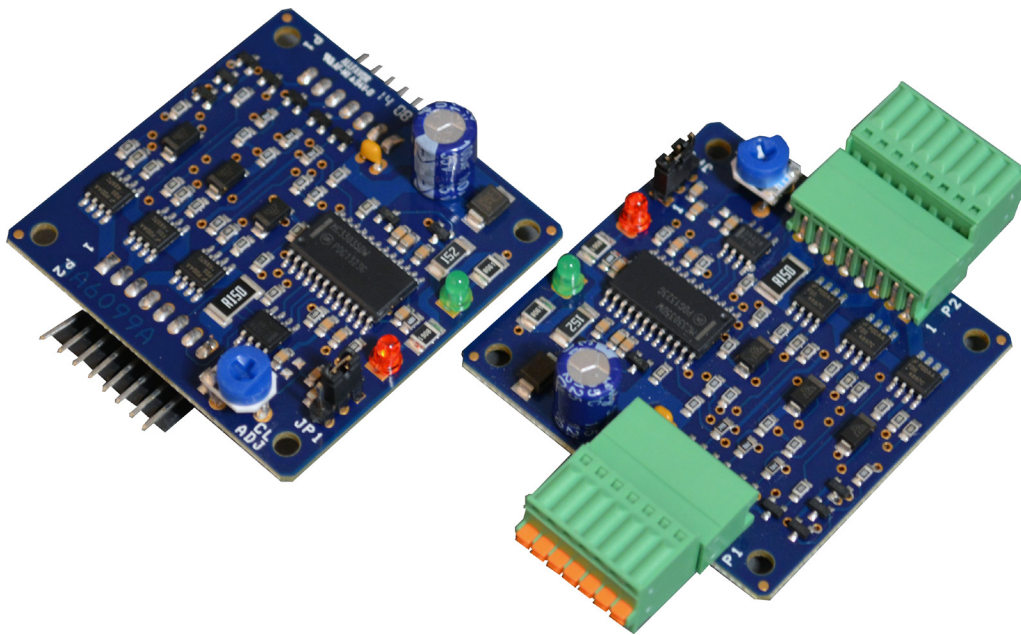

ANAHEIM AUTOMATION

4985 E. Landon Drive Anaheim, CA 92807
e-mail: info@anaheimautomation.com

(714) 992-6990 fax: (714) 992-0471
website: www.anaheimautomation.com

MDC151-024031 Driver Features

- Fixed Current Limit Setting 3.0 Amps
- 0V to 5V External Voltage Speed Control
- 2-Quadrant Operation
- Hall Sensor Feedback
- Constant Velocity Mode
- Short Circuit Protection
- Requires 10 - 24VDC
- Speed Out
- Run/Stop, Freewheel and Direction
- TTL-CMOS Compatible Inputs
- Compact Size
- Open Frame

General Description

The MDC151-024031 driver is designed to drive DC brushless motors at currents of up to 3A (peak) and 24V. Using hall sensor feedback, a constant velocity mode is set. The driver is protected against over current (cycle-by-cycle), hall sensor error and under voltage. When an error occurs, a fault light is turned on to notify the user. An external voltage (0-5VDC) can be used to control the speed. The direction of the motor can be preset by the direction control input. Other inputs to the drive include a run/stop and a motor freewheel input.

Fault Protection

If a motor current level exceeding the current limit set, an over current latch is activated, shutting off the output. This driver is equipped with a FAULT LED to alert the user of the following conditions.

1. Invalid Sensor Input Code
2. Over Current. The driver is equipped with cycle-by-cycle current limiting or over current latch.
3. Undervoltage Lockout activation at 9.1VDC for the input voltage and 4.5VDC for Hall Sensor voltage.

Power Supply/Ordering Information

Ordering Information	
Part Number	Description
MDC151-024031	10-24VDC, 3A Brushless Controller, Closed loop, Open-Frame
MDC151-024031-TB	10-24VDC, 3A Brushless Controller, Closed loop, Open-Frame with detachable terminal blocks
PS-35-24	DC Power Supply 24VDC at 1.5 Amps
PSA24V2.7A	DC Power Supply 24VDC at 2.7 Amps
CBL-AA4031	7 Pin Input Connector with 12", 22AWG Leads
CBL-AA6131	8 Pin Motor Connector with 12", 22AWG Leads
CON-6404407	7 Pin Connector with 0.100" Centers (Amp #640440-7)
CON-6404408	8 Pin Connector with 0.100" Centers (Amp #640440-8)

Specifications

Control Inputs:(P1, Pins 3-5)

TTL-CMOS Compatible

Logic "0" = 0-0.8VDC

Logic "1" = OPEN

All three inputs (run/stop, direction, and freewheel) are pulled up to 40k ohm resistors.

Run/Stop: (P1, Pin 3)

Logic "1" (open) - Motor will not run and if running will come to a hard stop

Logic "0" - Motor will run

Direction Control: (P1, Pin 4)

Logic "1" (open) - Clockwise

Logic "0" - Counterclockwise

Freewheel: (P1, Pin 5)

Logic "1" (open) - Motor is Enabled

Logic "0" - Motor is de-energized and will coast

Vcontrol: (P1, Pin 6)

To control the speed of the motor with an external DC voltage, 0VDC (min) - 5VDC (max)

Speed Output (PGout): (P1, Pin 7)

An open drain pulse output has a max rating of 30VDC/50mA.

8-pole motor RPM = 15 * PG OUT (in Hz)

6-pole motor RPM = 20 * PG OUT (in Hz)

4-pole motor RPM = 30 * PG OUT (in Hz)

Output Current Rating:

3.0 amperes per phase maximum operating peak current

(1.5 amperes per phase maximum operating continuous current)

Power Requirements: (P1, Pins 1 and 2)

10VDC (min) - 24VDC (max)

Operating Temperature:

Board: 0°-70° C

Hall Sensor Power Output:

6.25V @ 30mA maximum. Typical current draw from hall sensor is 20mA.

All three Hall Sensor inputs are pulled up through 20K ohm resistors.

Closed Loop (Constant Velocity Mode)

The driver is set for Closed Loop operation. Closed Loop operation is used for applications where speed regulation is needed. Under closed loop operation, the speed is regulated despite changes to the load.

If using an Anaheim Automation DC Brushless motor, the tables shown on the next page are the Close Loop potentiometer and jumper settings for each motor. The regulated speed of the motor is then controlled by adjusting external speed input. The motor speed can be monitored by measuring the pulse rate of PG OUT (P1 - pin 7).

If using a non-Anaheim Automation DC Brushless Motor.

1. Start with setting the jumpers on pins 1 and 2.
2. Set CL Adjust Pot to 50%.
3. Adjust the external speed input to 5V.
4. Decrease the closed loop gain by turning the pot CCW until the motor speed decreases to the maximum speed. If the rated speed does not change or cannot be varied, switch the jumpers to pin 2 and 3.

Anaheim Automation Motor Closed Loop Settings

4-Pole Motors

Motor	JP1	CL POT	MAX SPD (RPM)
BLWR092S-24V-4600	1-2	75%	4600
BLWR110S-15V-8000	1-2	75%	8000
BLWR111S-12V-15000	1-2	75%	15000
BLWR111S-24V-10000	1-2	75%	10000
BLWR112S-24V-3700	1-2	25%	3700
BLWR112S-36V-10000*	1-2	75%	7500
BLWR132S-24V-4000	1-2	25%	4000
BLWR231S-36V-4000*	1-2	25%	3000
BLWR231S-24V-11000	1-2	75%	11000
BLWS231S-24V-2000	2-3	75%	2000
BLWS232S-24V-1350	2-3	75%	1350
BLWS233D-24V-4000	1-2	25%	4000
BLWS233S-24V-4000	1-2	25%	4000

8-Pole Motors

Motor	JP1	CL POT	MAX SPD (RPM)
BLY171S-17V-8000	1-2	75%	8000
BLY172S-17V-9500	1-2	75%	9500
BLY171S-24V-4000	1-2	75%	4000
BLY172D-24V-4000	1-2	75%	4000
BLY172S-24V-4000	1-2	75%	4000
BLY173D-24V-4000	1-2	75%	4000
BLY173S-24V-4000	1-2	75%	4000
BLY174D-24V-4000	1-2	75%	4000
BLY174S-24V-4000	1-2	75%	4000
BLY171S-12V-200	2-3	25%	200
BLY171S-15V-8000	1-2	75%	8000
BLY171S-17V-8000	1-2	75%	8000
BLY172D-12V-230	2-3	25%	230
BLY174D-24V-12000	1-2	75%	12000
BLY172S-12V-500	2-3	100%	500

***Note: 36V motors ran at 24VDC. Speed is set to run at 75% of rated value.**

Commutation Sequence

	Step					
	1	2	3	4	5	6
Phase A	+	Z	-	-	Z	+
Phase B	Z	+	+	Z	-	-
Phase C	-	-	Z	+	+	Z
Hall A	1	1	0	0	0	1
Hall B	0	1	1	1	0	0
Hall C	0	0	0	1	1	1

120° Hall Spacing Sequence Forward

	Step					
	1	2	3	4	5	6
Phase A	-	Z	+	+	Z	-
Phase B	Z	-	-	Z	+	+
Phase C	+	+	Z	-	-	Z
Hall A	1	1	0	0	0	1
Hall B	0	1	1	1	0	0
Hall C	0	0	0	1	1	1

120° Hall Spacing Sequence Reverse

	Step					
	1	2	3	4	5	6
Phase A	+	Z	-	-	Z	+
Phase B	Z	+	+	Z	-	-
Phase C	-	-	Z	+	+	Z
Hall A	1	1	1	0	0	0
Hall B	0	1	1	1	0	0
Hall C	0	0	1	1	1	0

60° Hall Spacing Sequence Forward

	Step					
	1	2	3	4	5	6
Phase A	-	Z	+	+	Z	-
Phase B	Z	-	-	Z	+	+
Phase C	+	+	Z	-	-	Z
Hall A	1	1	1	0	0	0
Hall B	0	1	1	1	0	0
Hall C	0	0	1	1	1	0

60° Hall Spacing Sequence Reverse

+ = Top Transistor ON, Bottom Transistor OFF, Current Flows into this wire

- = Top Transistor OFF, Bottom Transistor ON, Current Flows out of this wire

Z = Top Transistor OFF, Bottom Transistor OFF, No current into or out of this wire (High Impedance)

Motor Connection

Refer to the hookup diagram for typical driver applications. When connecting a motor for the first time, connect the hall sensor wires (5 of them) to the driver. **DO NOT CONNECT THE PHASES YET.** Turn on power and rotate the motor by hand. If the RED FAULT LED comes on, the hall phases are incorrectly wired. If the RED FAULT LED does not come on then the hall wires are connected correctly. Power the unit down and proceed to connect the motor phases. If the motor does not run or runs erratically, power down and check the speed potentiometer and make sure the phases are connected correctly. There are six different ways to connect the phase wires, and normally only two will allow the motor to rotate, but only one is correct. If the direction of the motor is changed and the no-load current of the motor is approximately the same and the motor runs smoothly in both directions then the phase wires are correct.

The wiring of the motor phases should be separated from the hall and input connections to not allow a possible source of interference.

Connecting to the MDC151-024031

The MDC151-024031 is designed with cost savings and size as two of the primary design criteria. For this reason, the MTA-100 series connector was chosen for these products as a reliable small and low cost connector. This is a common Insulation Displacement Connector (IDC) manufactured by AMP Corporation. The inputs to the driver are on a 7-pin connector and the motors are on a 8-pin connector. These connectors are not supplied with the driver, but can be purchased from Anaheim Automation or AMP/Tyco Electronics.

The two images below show how a hand tool can be used to quickly make the cable to connect to the driver. This cable can be made in approximately 10 seconds per wire using the hand tool.

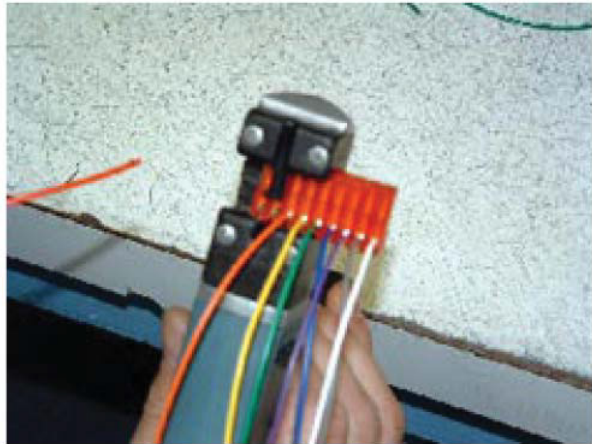

Tooling from AMP/Tyco Electronics	
Part Number	Description
58074-1	Manual Hand Tool with Interchangeable Head (shown above)
58075-1	Air Hand Tool with Interchangeable Head
58338-1	Air Bench Mount Tool with Interchangeable Head and Foot Switch
58246-1	Die Head for Closed End MTA-100 Connectors (shown above)

Tooling from AMP/Tyco Electronics	
Part Number	Description
640440-7	7 Pin MTA-100 Connector, Closed End with Lock, 22 AWG Red, Tin Plated
640440-8	8 Pin MTA-100 Connector, Closed End with Lock, 22 AWG Red, Tin Plated
640441-7	7 Pin MTA-100 Connector, Closed End with Lock, 24 AWG White, Tin Plate
640441-8	8 Pin MTA-100 Connector, Closed End with Lock, 24 AWG White, Tin Plated
640442-7	7 Pin MTA-100 Connector, Closed End with Lock, 26 AWG Blue, Tin Plated
640442-8	8 Pin MTA-100 Connector, Closed End with Lock, 26 AWG Blue, Tin Plated

Terminal Descriptions

Pin #	Description
1	VIN (10-24VDC)
2	GND
3	Run/Stop
4	Direction
5	Freewheel
6	VControl
7	PGout

P1: Power, Control Inputs and Outputs

Pin #	Description
1	Phase A
2	Phase B
3	Phase C
4	Hall Sensor Power
5	Hall Sensor A
6	Hall Sensor B
7	Hall Sensor C
8	Hall Sensor Ground

P2: Motor Hall Terminals and Motor Phase Terminals

Motor Freewheel

The motor freewheel feature allows the de-energizing of the motor phases. A high (open) input at this input causes the motor to run at the given speed, while a low at this input causes the motor to coast to a stop.

Motor Run/Stop

The motor run/stop feature allows the stopping of a motor by shorting out the bottom drives of the three phases. A low at this input allows the motor to run, while a high (open) input does not allow motor operation and if operating causes rapid deceleration.

Motor Direction

The motor direction feature allows the changing of the rotation of the motor. This input should not be changed while motion is in progress. A high (open) input causes the motor to turn in the CW direction, while a low at this input causes the motor to turn in the CCW direction.

Note: Avoid changing the direction of rotation when the motor is already running any one direction.

The following instructions must be followed to prevent permanent drive failure due to over-current conditions that exist in dynamic direction reversals of the motor:

1. Stop the motor by grounding the RUN/STOP input
2. Wait for at least 500mS
3. Change the direction with the DIRECTION input
4. Run the motor by removing ground signal on the RUN/STOP input

Speed Adjust Setting

The speed may be varied at Vcontrol from 0V-5V maximum. If a voltage other than 0V to 5V is needed to control the speed of the motor, contact Anaheim Automation for custom tuning of the Vcontrol input.

Speed Output

The PG OUT terminal (P1 - pin 7) is used to determine the speed of the motor shaft. An open drain output is shown at a rate of 4 pulses for 1 revolution of an 8-pole motor, 3 pulses for 1 revolution of a 6-pole motor, and 2 pulses for 1 revolution of a 4-pole motor. Max rating of 30VDC/50mA.

# Poles	RPM
8	15 * PG OUT (in Hz)
6	20 * PG OUT (in Hz)
4	30 * PG OUT (in Hz)

Heating Considerations

The temperature of the board should never be allowed to rise above 70° Celsius. If necessary, air should be blown across the heat sink to maintain suitable temperatures.

Torque Curves

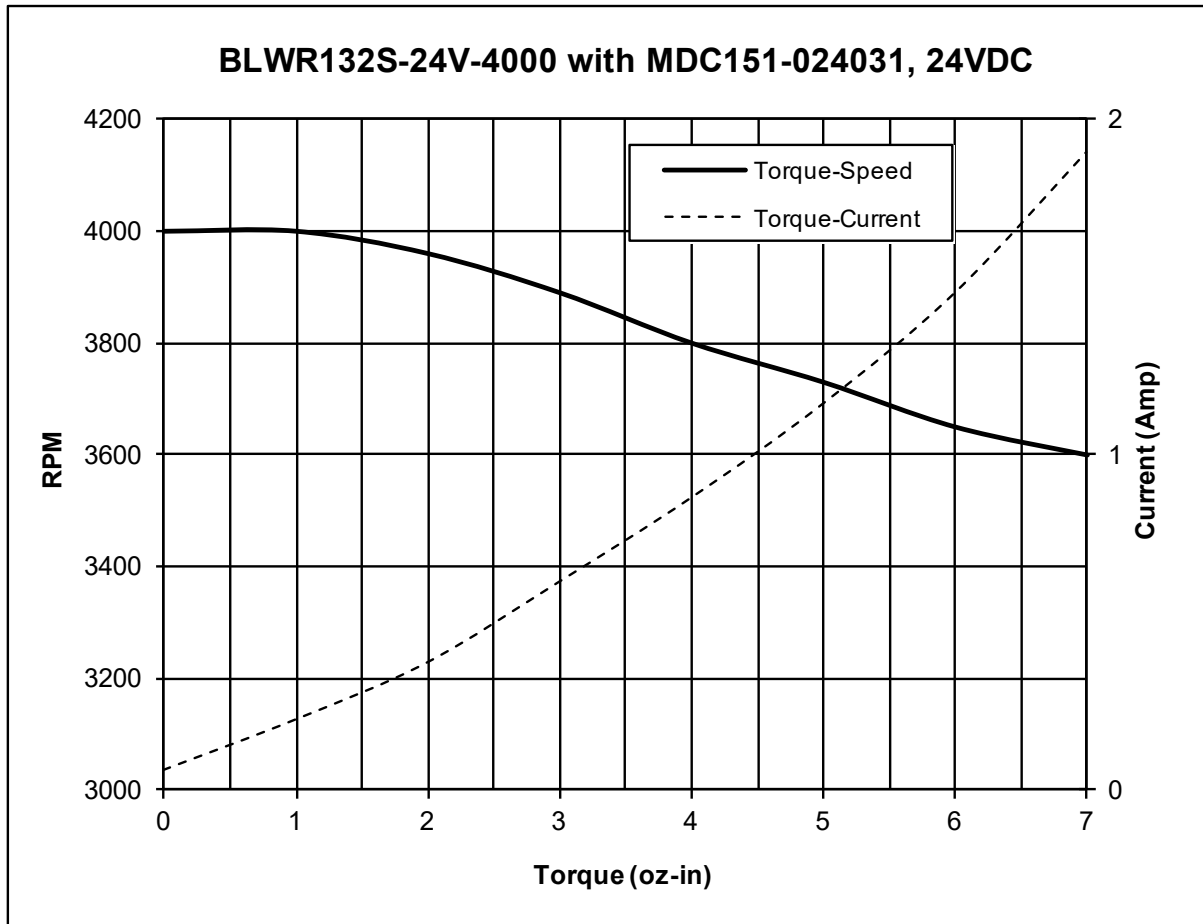

Typical Wiring Diagram

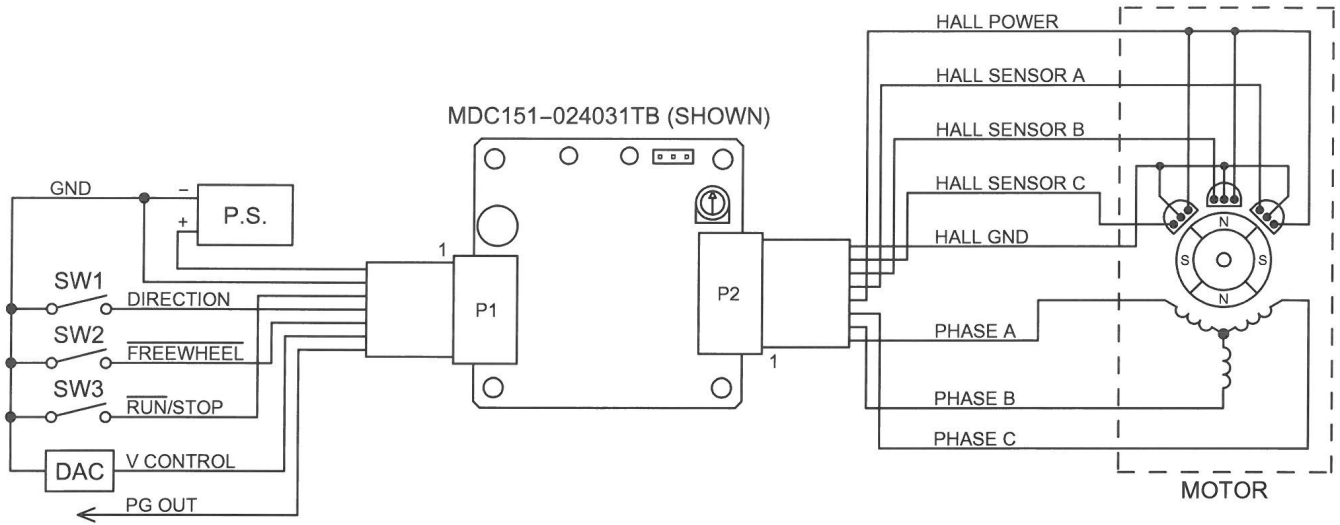

Dimensions

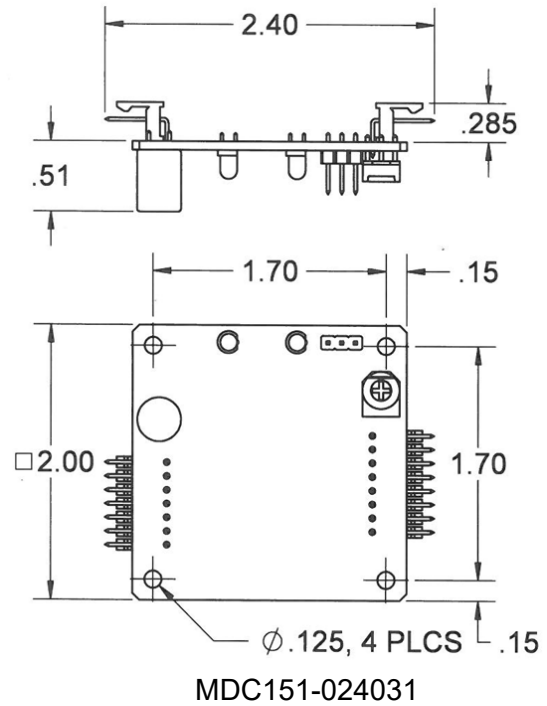
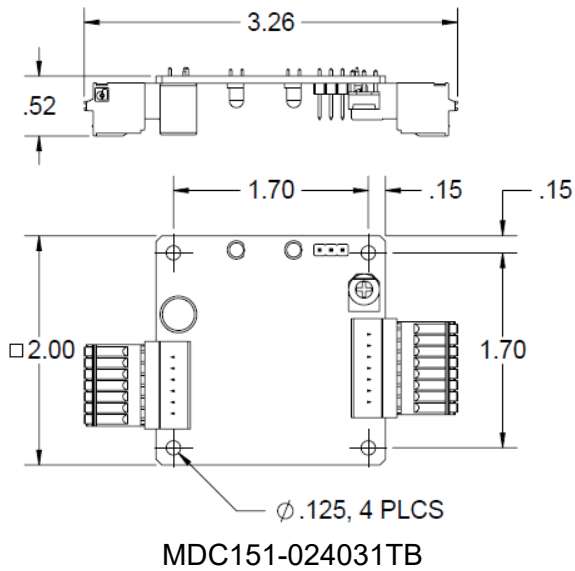

***All units in inches**

COPYRIGHT

Copyright 2013 by Anaheim Automation. All rights reserved. No part of this publication may be reproduced, transmitted, transcribed, stored in a retrieval system, or translated into any language, in any form or by any means, electronic, mechanical, magnetic, optical, chemical, manual, or otherwise, without the prior written permission of Anaheim Automation, 4985 E Landon Drive, Anaheim, CA 92807.

DISCLAIMER

Though every effort has been made to supply complete and accurate information in this manual, the contents are subject to change without notice or obligation to inform the buyer. **In no event will Anaheim Automation be liable for direct, indirect, special, incidental, or consequential damages arising out of the use or inability to use the product or documentation.**

Anaheim Automation's general policy does not recommend the use of its' products in life support applications wherein a failure or malfunction of the product may directly threaten life or injury. Per Anaheim Automation's Terms and Conditions, the user of Anaheim Automation products in life support applications assumes all risks of such use and indemnifies Anaheim Automation against all damages.

LIMITED WARRANTY

All Anaheim Automation products are warranted against defects in workmanship, materials and construction, when used under Normal Operating Conditions and when used in accordance with specifications. This warranty shall be in effect for a period of twelve months from the date of purchase or eighteen months from the date of manufacture, whichever comes first. **Warranty provisions may be voided if products are subjected to physical modifications, damage, abuse, or misuse.**

Anaheim Automation will repair or replace at its' option, any product which has been found to be defective and is within the warranty period, provided that the item is shipped freight prepaid, with previous authorization (RMA#) to Anaheim Automation's plant in Anaheim, California.

TECHNICAL SUPPORT

If you should require technical support or if you have problems using any of the equipment covered by this manual, please read the manual completely to see if it will answer the questions you have. If you need assistance beyond what this manual can provide, contact your Local Distributor where you purchased the unit, or contact the factory direct.

ANAHEIM AUTOMATION