

# BSC151-024031 Brushless Speed Controller



## FEATURES

- Maximum Current Limit of 3.0 Amps (peak)
- Potentiometer Speed Control
- Integrated Power, Brake and Direction Switches
- Constant Velocity Mode
- Short Circuit Protection
- 2-Quadrant Operation
- Hall Sensor Feedback
- Requires 10-24VDC
- Speed Out



## DESCRIPTION

The BSC151-024031 is a speed controller that has integrated easy to use user controls and the MDC151-024031 driver inside and is designed to drive DC brushless motors at currents of up to 3A (peak) and 24V. Using hall sensor feedback, a constant velocity mode can be achieved. The driver is protected against over current (cycle-by-cycle or latched), hall sensor error and under voltage. When an error occurs, an internal fault light is turned on to notify the user. Included on the driver is an internal potentiometer to control closed loop compensation control. In addition, there are integrated control switches for power, the direction, Run/Stop, and a speed control potentiometer to adjust the motor speed mounted for easy user interface.

## DIMENSIONS

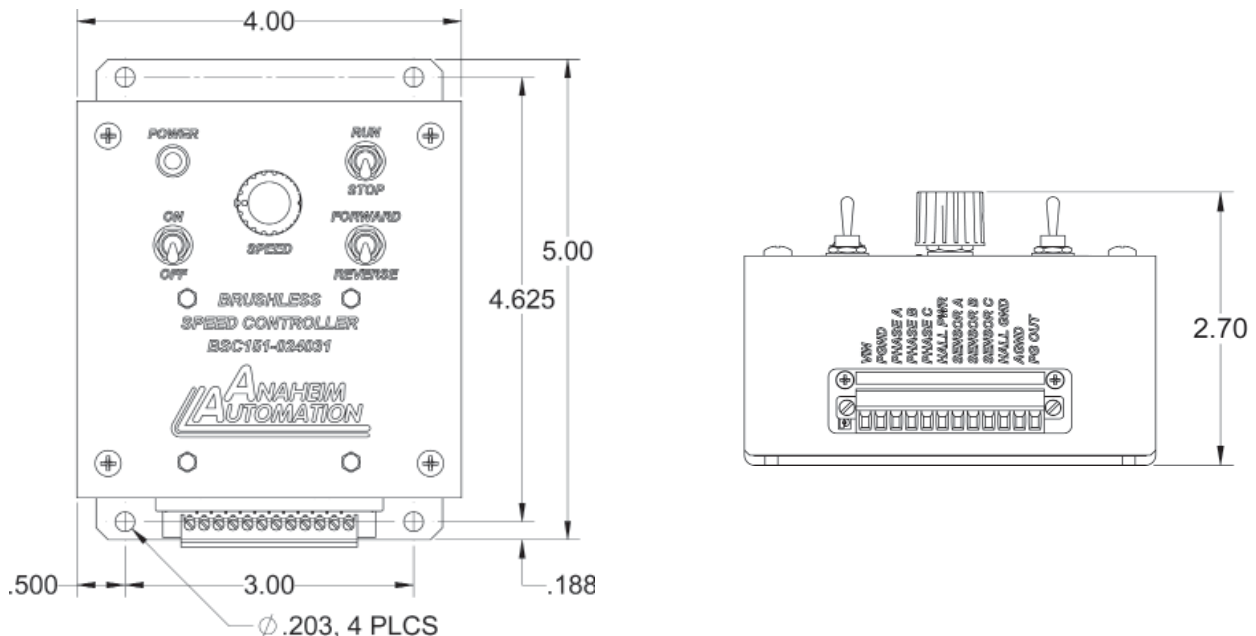

L011535

All units are in inches

WIRING INFORMATION

