

ENC-A4TS Miniature Encoder without Index Channel



FEATURES

- Miniature Size
- 100 to 1000 Cycles per Revolution (CPR)
- Tracks 0 to 30,000 Cycles per Second
- Off-Axis Mounting Tolerance of 0.010"
- 2-Channel Quadrature TTL Squarewave Outputs
- Operating Temperature of -20° to +100° C
- Powered from a Single +5VDC Power Supply



DESCRIPTION

With an acceptable minimum shaft length of 0.275" and maximum shaft length of 0.395". Shaft sizes ranging from 0.079" to 0.250" in diameter, the ENC-A4TS is a single-ended miniature encoder designed for high volume applications with space limitations. The ENC-A4TS module is designed to detect the rotary position with a code wheel. When attached to the end of a shaft, the encoder provides digital feedback information. This single-ended miniature encoder consists of LED source lens and a monolithic detector IC enclosed in a small polymer package. These modules implement phased array detector technology providing superior performance and tolerances over traditional aperture mask type encoders. The ENC-A4TS series provides digital quadrature outputs on all resolutions and are capable of sinking or sourcing 8 mA each. These encoders are powered from a single +5VDC power supply and are RoHS compliant.

ORDERING INFORMATION

ENC - A4TS - 0100 - 250 - H - M

CPR	
0100	0256
0108	0300
0120	0360
0125	0400
0128	0500
0200	0512
0250	1000

Bore Size	
079 = 2mm	157 = 4mm
091 = 2.3mm	188 = 3/16"
098 = 2.5mm	197 = 5mm
118 = 3mm	236 = 6mm
125 = 1/8"	250 = 1/4"

Cover Options
H = Hole in Cover
Blank = Cover

Base Options
M = Metric Mounting Screws
Blank = Default

L011455

DIMENSIONS

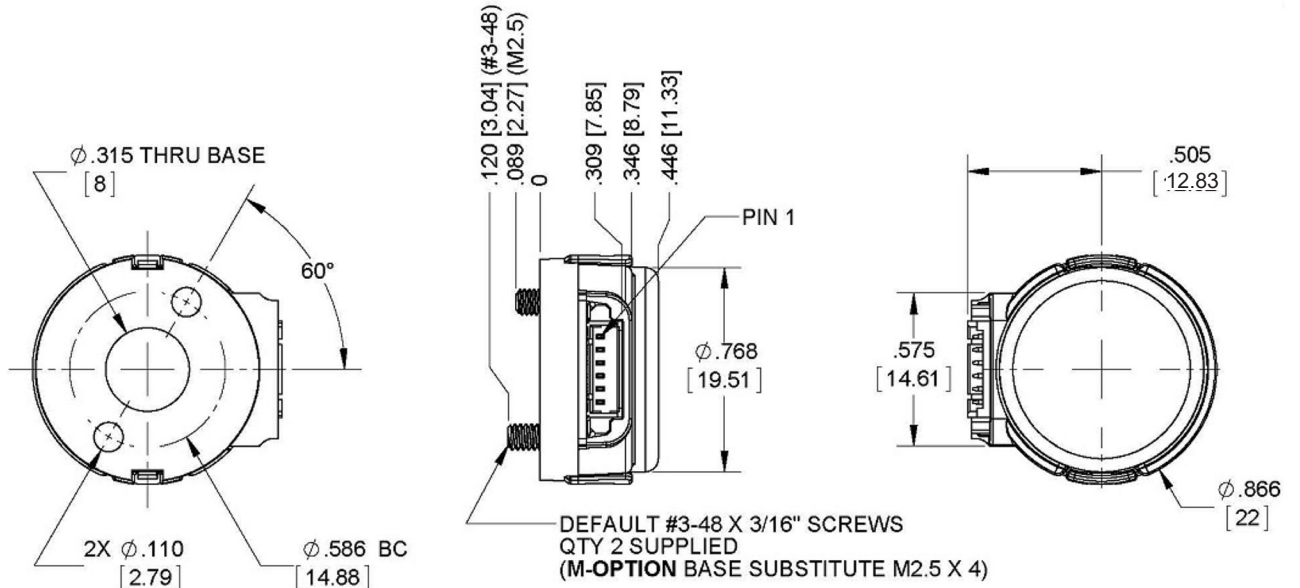

COVER OPTIONS

**H-OPTION COVER
(COVER HOLE FOR EXTENDED SHAFTS)**

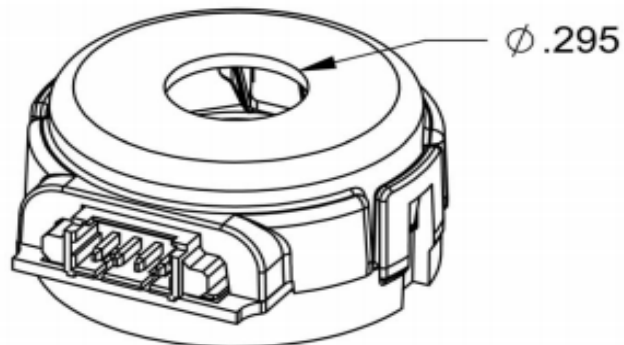

DEFAULT #3-48 X 3/16" SCREWS
 QTY 2 SUPPLIED
 (M-OPTION BASE SUBSTITUTE M2.5 X 4)

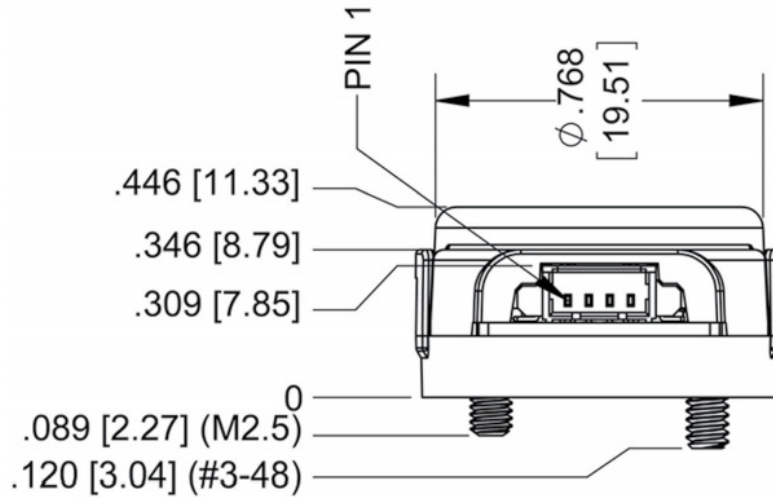

SINGLE-END ENCODER TIMING DIAGRAMS

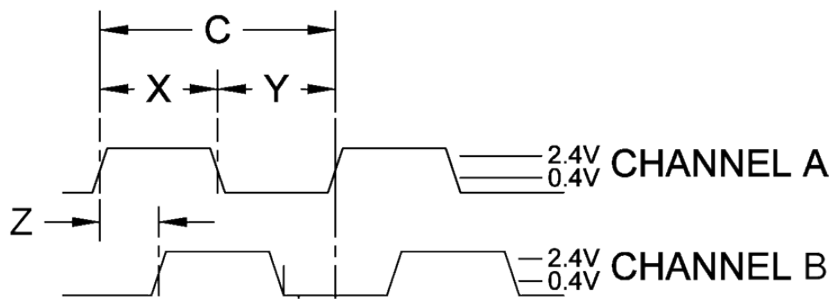

ROTATION:
 CW - B LEADS A, CCW - A LEADS B

SINGLE-ENDED ENCODER PINOUT
 TOP OF ENCODER FACING PLUG

Pin #	Function	ENC-CBL-CA3285-1 ENC-CBL-CA3286-1
1	+5VDC	Orange or Red
2	Channel A	Blue or Green
3	Ground	Brown or Black
4	Channel B	Yellow

Model #	Description
CPR(N):	The Number of Cycles Per Revolution
One Shaft Rotation:	360 mechanical degrees, N cycles
One Electrical Degree (°e):	1/360th of one cycle
One Cycle (C):	360 electrical degrees (°e). Each cycle can be decoded into 1 or 4 codes, referred to as X1 or X4 resolution multiplication
Symmetry:	A measure of the relationship between (X) and (Y) in electrical degrees, nominally 180 °e
Quadrature (Z):	The phase lag or lead between channels A and B in electrical degrees, nominally 90 °e

Parameter	Min	Typ	Max	Units
Supply Current (No Load)	-	21	27	mA
High Level Output Voltage* (I _{OL} = 6 mA)	2.4	-	-	Volts
Low Level Output Voltage (I _{OH} = -1 mA)	-	-	0.4	Volts
Rise Time (CL = 25 pF, RL = 2.7 k Ω)	-	500	-	ns
Fall Time	-	100	-	ns

* Unloaded high level output voltage is 4.80V typically, 4.2V minimum.

Parameter	Max	Units
Vibration (5 to 2kHz)	20	g
Shaft Axial Play	+/- 0.02	in.
Off-Axis Mounting Tolerance	0.010	in.
Acceleration	250,000	rad/sec ²
Electrostatic Discharge	±12	kV
Shock, 6 Milliseconds, Half-Sine	75	G

Parameter	Typ	Units
Symmetry, S	180 ± 16	°e
Quadrature Delay, Q	90 ± 12	°e

Recommended Operating Conditions	Min	Max	Units
Temperature	-20	100	°C
Supply Voltage	4.5	5.5	Volts
Load Capacitance	-	100	pF
Count Frequency	-	100	kHz

Mechanical	Value	Units
Minimum Shaft Length*	0.275	in.
Maximum Shaft Length*	0.395	in.
Mounting Screw Torque	2-3	in-lbs

*Including Axial play

Speed Calculation	Units
All CPR Values (30,000/CPR)*60	RPM

*60,000 RPM is the maximum RPM due to mechanical limitations.

Centering

Centering Tools are optional, but recommended for a more precise installation.

ENC-MCTOOL-250

Bore Size	
059=1.5mm	188=3/16"
079=2mm	197=5mm
125=1/8"	236=6mm
156=5/32"	250=1/4"
157=4mm	

Cables

The following cables are compatible with Anaheim Automation's A4TS series encoder. Select a cable length from the table below.

Cable Part Number	Length
ENC-CBL-CA-MIC4-SH-NC-1	1 ft.
ENC-CBL-CA-MIC4-SH-NC-5	5 ft.
ENC-CBL-CA-MIC4-SH-NC-10	10 ft.
ENC-CBL-CA-MIC4-SH-NC-20	20 ft.

Mating Connector

Micro mating connector shell (Molex# 51021-0400) and 4 pins for 26-28 AWG wires (Molex # 50079-8100)

NOTE: For pricing and other information on cables and centering tools, please visit Accessories on our website.