

ENC-S4TD Differential Miniature Optical Shaft Encoder Without Index



FEATURES

- Miniature Size
- High Strength Snap-In Polarized Connector
- Max. Shaft Speed 15000 RPM
- Operating Temperature of -20° to +100°C
- 100 to 1000 Cycles Per Revolution (CPR)
- Powered From Single +5VDC Power Supply
- 2-Channel Quadrature TTL Square Wave Outputs
- RoHS Compliant and REACH Certified
- Differential Output



DESCRIPTION

The ENC-S4TD has shaft sizes ranging from .125" to .250" in diameter, the ENC-S4TD is a Differential Miniature Shaft Encoder designed for high volume applications with space limitations. The ENC-S4TD module is designed to detect the rotary position with a code wheel. With the Encoder attached to the end of the shaft, the encoder provides digital feedback information. This differential miniature encoder consists of LED source lens and monolithic detector IC enclosed in a smaller polymer package. These modules implement phased array detector technology providing superior performance and tolerances over traditional aperture mask type encoders. The ENC-S4TD Series provides a minimum Differential Output Voltage of 3.0V and typically is at 3.8V. These encoders are powered from a single +5VDC power supply and are RoHS compliant.

CUSTOM ORDER LAYOUT

ENC - S4TD - 0100 - 125 - B

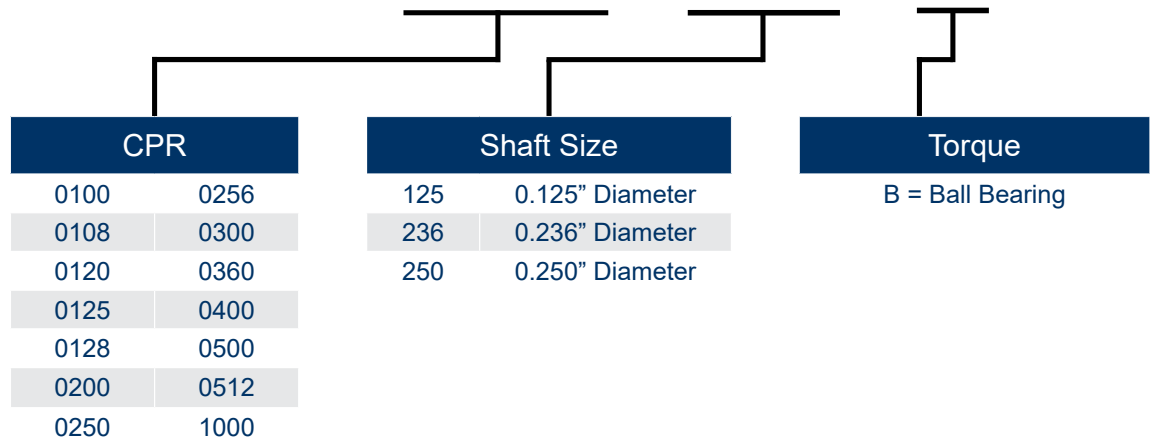

L011552

DIMENSIONS

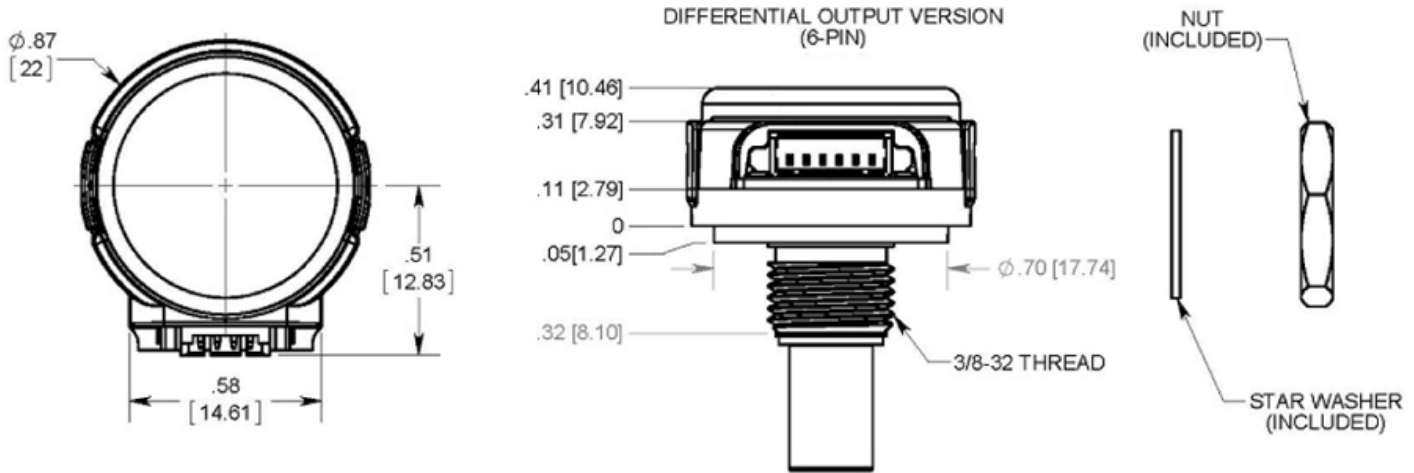

SHAFT OPTIONS

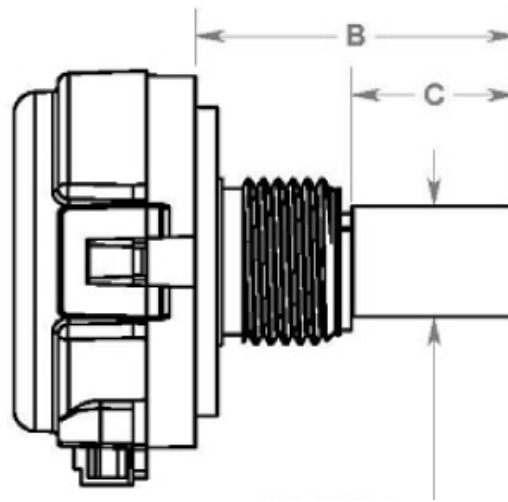

	Torque	Shaft Ø	A	B	C
Ball Bearing		1/8 (.125)	.1250 [3.175]	.740 [18.80]	.375 [9.53]
		6mm (.236)	.2362 [6]	.725 [18.42]	.375 [9.53]
		1/4" (.250)	.2500 [6.350]	.725 [18.42]	.375 [9.53]

Dimension C is Length of Shaft Ø A

DIFFERENTIAL ENCODER TIMING DIAGRAMS

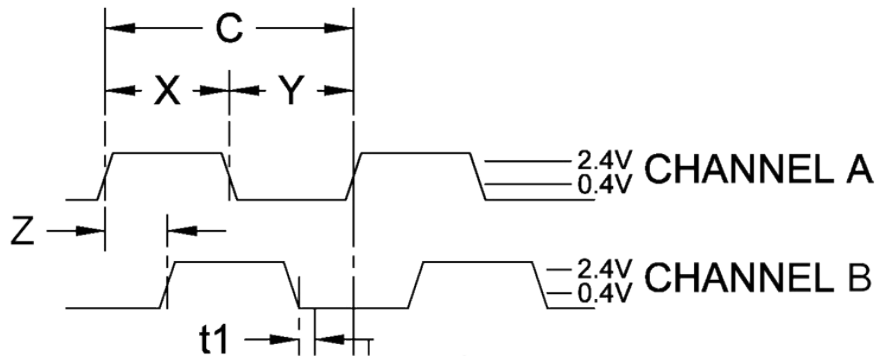

ROTATION:
CW - B LEADS A, CCW - A LEADS B

DIFFERENTIAL ENCODER PINOUT TOP OF ENCODER FACING PLUG

Pin #	Function
1	Ground
2	A Channel
3	A- Channel
4	+5VDC
5	B Channel
6	B- Channel

Model #	Description
CPR(N):	The Number of Cycles Per Revolution
One Shaft Rotation:	360 mechanical degrees, N cycles
One Electrical Degree (°e):	1/360th of one cycle
One Cycle (C):	360 electrical degrees (°e). Each cycle can be decoded into 1 or 4 codes, referred to as X1 or X4 resolution multiplication
Symmetry:	A measure of the relationship between (X) and (Y) in electrical degrees, nominally 180 °e
Quadrature (Z):	The phase lag or lead between channels A and B in electrical degrees, nominally 90 °e

Parameter	Max	Units	Recommended Operating Conditions	Min	Max	Units
Vibration (5 to 2kHz)	20	g	Temperature	-40	100	°C
Shaft Axial Play	+/- 0.02	in.	Max Relative Humidity	-	90	%
Off-Axis Mounting Tolerance	0.010	in.	Load Capacitance	-	100	pF
Acceleration	250,000	rad/sec ²	Count Frequency	-	100	kHz

Parameter	Min	Typ	Max	Units	Parameter	Typ	Units
Supply Voltage	4.5	5.0	5.5	Volts	Symmetry, S	180 ± 16	°e
Supply Current (No Load)	-	23	29	mA	Quadrature Delay, Q	90 ± 12	°e
Differential Output Voltage (RL = 100 ohm)	2.4	-	-	Volts			
Differential Output Rise/Fall Time	-	-	20	ns			

Speed Calculation	Units
All CPR Values (30,000/CPR)*60	RPM

*60,000 RPM is the maximum RPM due to mechanical limitations.

Cables:

The following cables are compatible with Anaheim Automation's S4TD series encoder. Select a cable length from the table below:

Cable Part Number	Length
ENC-CBL-CA-MIC6-SH-NC-1	1 ft.
ENC-CBL-CA-MIC6-SH-NC-5	5 ft.
ENC-CBL-CA-MIC6-SH-NC-10	10 ft.
ENC-CBL-CA-MIC6-SH-NC-20	20 ft.

Mating Connector:

Micro mating connector shell (Molex# 51021-0600) and 6 pins for 26-28 AWG wires (Molex # 50079-8100)

NOTE: For pricing and other information on cables and centering tools, please visit Accessories on our website.

Centering Tools:

Centering tools are optional, but recommended for a more precise installation.

ENC-MCTOOL - 250

Bore Size	
059=1.5mm	188=3/16"
079=2mm	197=5mm
125=1/8"	236=6mm
156=5/32"	250=1/4"
157=4mm	