

ENC-A6SI Single-Ended Optical Kit Encoder with Index Channel



FEATURES

- 100 to 10,000 Cycles Per Revolution (CPR)
- 2 Channel Quadrature TTL Squarewave Outputs
- Operating Temperature of -40° to +100° C
- Powered from a +5VDC Power Supply
- Positive Latching Connector
- Allows for ±0.010" Axial Shaft Play
- RoHS Compliant and REACH Certified



DESCRIPTION

The ENC-A6SI is a Single-Ended Optical Kit Encoder with Index designed for quick and simple assembly that fits any shaft diameters from 0.079" to 1". It fits to any shaft length over 0.445" diameter when equipped with the Hole in Cover option. However, the default required shaft length is from 0.445" to 0.570" and the Cover Extension required shaft length is 0.445" to 0.750". The ENC-A6SI module is designed to detect the rotary position with a code wheel. The ENC-A6SI can be attached to any existing shaft to provide digital feedback information. This Single-Ended Encoder consists of a highly accurate aligned solid state light source and monolithic phased array sensor, when combined together they provide a system extremely tolerant to mechanical misalignments. The ENC-A6SI Single-Ended Optical Kit Encoder has a molded, rugged 20% glass filled polycarbonate that utilizes a 5-Pin latching connector.

ORDERING INFORMATION

ENC - A6SI - 0100 - 079 - H - M

Index	CPR			Bore Size		Cover Options
I = Index (3rd Channel)	0100	1800	5000	079 = 2mm	375 = 3/8"	E = Cover Extension (1)
	0200	2000	7200	118 = 3mm	394 = 10mm	H = Hole in Cover
	0400	2048	8000	125 = 1/8"	472 = 12mm	Blank = Default
	0500	2500	8192	156 = 5/32"	500 = 1/2"	
	0512	3600	10000	157 = 4mm	551 = 14mm	
	1000	4000		188 = 3/16"	625 = 5/8"	
	1024	4096		197 = 5mm	750 = 3/4"	
				236 = 6mm	787 = 20mm	
				250 = 1/4"	875 = 7/8"	
				313 = 5/16"	984 = 25mm	
				315 = 8mm	1000 = 1"	

Base Options
3 = 0.125" Diameter for Three Base Mounting Holes (2)
M = Adds 4-Hole Mounting Adapter Plate
Blank = Default

(1) With Cover Extension "E" must choose bore size 079 (2mm) to 394 (10mm)

(2) With Base Option "3" must choose bore size 079 (2mm) to 394 (10mm)

L011733

Default Cover and Base Option

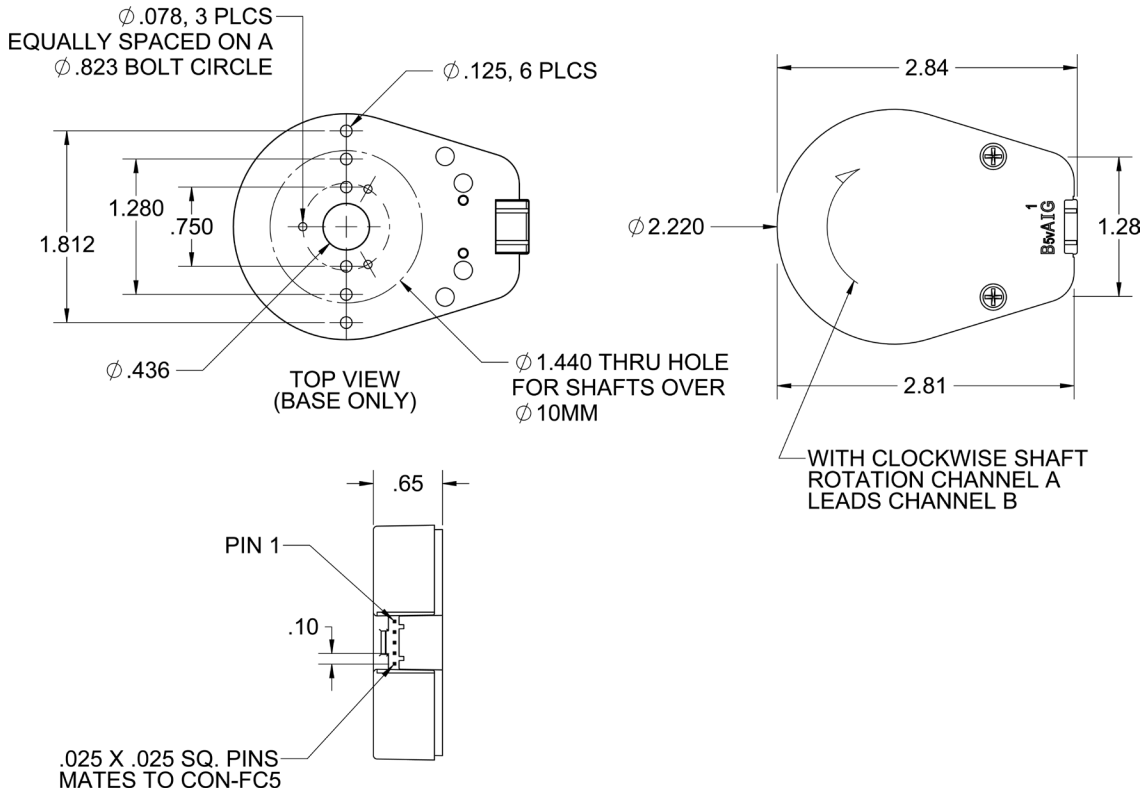

Note: Required shaft length is 0.445-0.570 inches.

E-OPTION COVER (EXTENSION FOR SHAFT LENGTHS UP TO .750 [19.05])

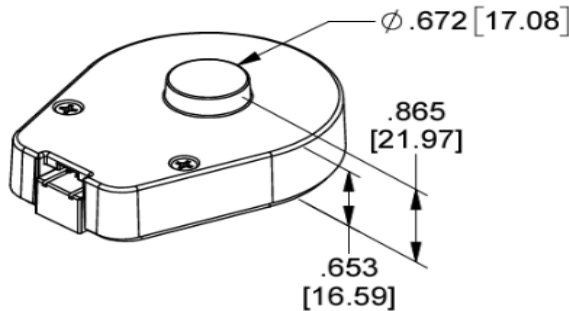

E-Option provides a cylindrical extension cover for longer shafts of up to 0.750". The required shaft length is 0.445" to 0.750".

H-OPTION COVER (HOLE FOR SHAFT LENGTHS OVER .750 [19.05])

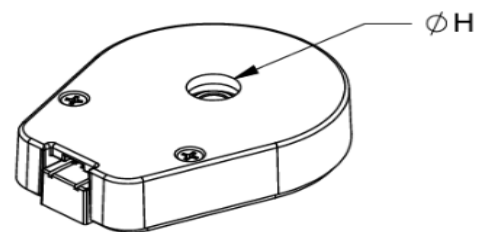

$H = .438$ [11.13] FOR SHAFT SIZES $\leq \phi .394$ [10]
 $H = 1.047$ [26.59] FOR SHAFT SIZES $> \phi .394$ [10]

H-Option adds a hole to the cover for the shaft to pass through. For shafts of 2mm to 10mm, a 0.438" diameter hole is supplied. For shafts of 12mm to 1.000", a 1.047" diameter hole is supplied.

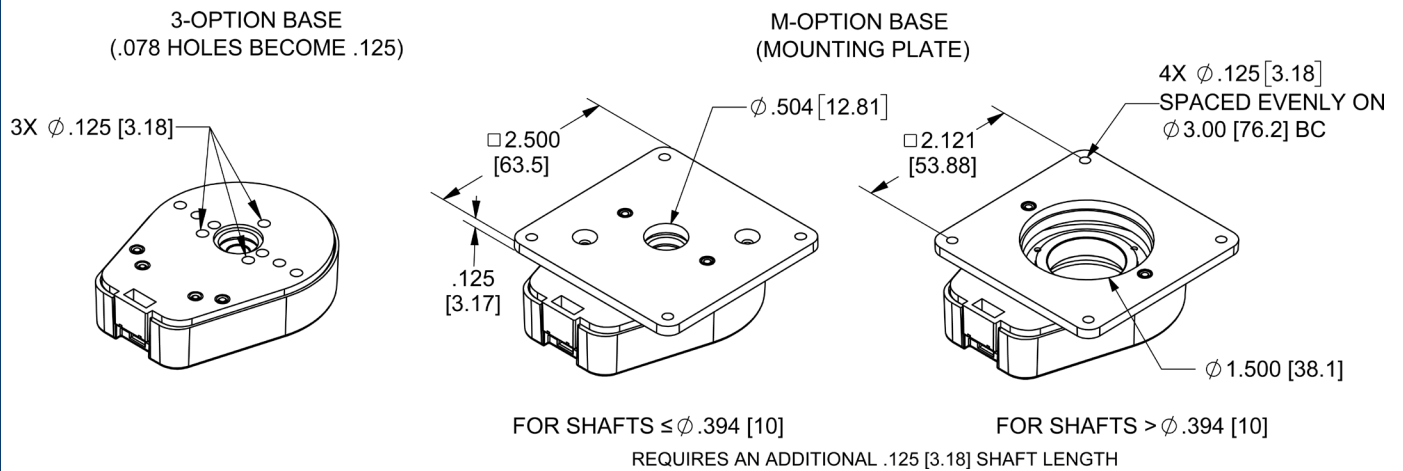

Base Options:	Description
3 - Option	3-Option makes three of these hole diameters .125"
M - Option	M-Option, this adapter plate is for mounting to a 3" diameter bolt circle.

(Note: Base Mounting Screws are NOT included. #2-56 or M2.5 #4-40 screws can be used to mount the base to your mounting surface.)

SINGLE-ENDED ENCODER PINOUT

Pin #	Function
1	Ground
2	Index
3	Channel A
4	+5VDC Input
5	Channel B

Note: 5-Pin Single Ended Mating Connector is Molex Type 50-57-9405

SINGLE-ENDED TIMING DIAGRAMS

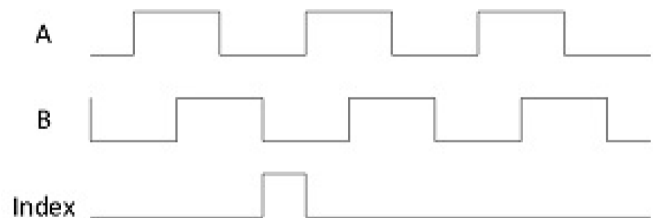

Terminology	Description
CPR(N):	The Number of Cycles Per Revolution
One Shaft Rotation:	360 mechanical degrees, N cycles
One Electrical Degree (°e):	1/360th of one cycle
One Cycle (C):	360 electrical degrees (°e). Each cycle can be decoded into 1 or 4 codes, referred to as X1 or X4 resolution multiplication
Symmetry:	A measure of the relationship between (X) and (Y) in electrical degrees, nominally 180 °e
Quadrature (Z):	The phase lag or lead between channels A and B in electrical degrees, nominally 90 °e
Index (CH I):	The Index Output goes high once per revolution, coincident with the low states of channels A and B, nominally 1/4 of one cycle (90°e)

Recommended Operating Conditions	Min	Max	Units
Temperature (CPR < 3600)	-40	100	°C
Temperature (CPR ≥ 3600)	-25	100	°C
Electrostatic Discharge, IEC 61000-4-2	-4	+4	kV

Parameter	Max	Units
Vibration (5Hz to 2kHz)	20	g
Max Shaft Axial Play	+/- 0.01	in.
Max Shaft Eccentricity Plus Radial Play	0.004	in.
Max Acceleration	250,000	rad/sec ²
Weight		
Single-Ended	0.09	lbs
Differential	0.11	lbs
Codewheel Moment of Inertia	8.9 x 10 ⁻⁵ for bore < 12mm 4.0 x 10 ⁻⁴ for bore ≥ 12mm	oz-in-s ²
Encoder Base Plate Thickness	0.135	in.

Parameter	Min	Typ	Max	Units
Supply Voltage	4.5	5.0	5.5	Volts
Supply Current				
CPR < 1000, no load	-	27	33	mA
CPR ≥ 1000 and < 3600, no load	-	54	62	
CPR ≥ 3600, no load	-	72	85	
Output Low				
I _{OL} = 8mA max (CPR < 3600)	-	-	0.5	Volts
I _{OL} = 5mA max (CPR ≥ 3600)	-	-	0.5	mA
no load (CPR < 3600)	-	0.05	-	mA
no load (CPR ≥ 3600)	-	0.25	-	mA
Output High*				
I _{OH} = -8mA max (CPR < 3600)	2.0	-	-	Volts
I _{OH} = -5mA max (CPR ≥ 3600)	2.0	-	-	Volts
no load (CPR < 3600)	-	4.8	-	Volts
no load (CPR ≥ 3600)	-	3.5	-	Volts
Output Current Per Channel (CPR < 3600)	-8.0	-	8.0	mA
Output Current Per Channel (CPR ≥ 3600)	-5.0	-	5.0	mA
Output Rise Time (CPR < 3600)	-	110	-	nS
Output Rise Time (CPR ≥ 3600)	-	50	-	nS
Output Fall Time (CPR < 3600)	-	35	-	nS
Output Fall Time (CPR ≥ 2000)	-	50	-	nS

Speed Calculation		Units
CPR ≤ 2500	18x10 ⁶ / CPR	RPM
CPR > 2500 and ≤ 5000	21.6x10 ⁶ / CPR	RPM
CPR > 5000	43.2x10 ⁶ / CPR	RPM

Cables:

The following cables are compatible with Anaheim Automation's A6SI series encoder. Select a cable length from the table below:

Cable Part Number	Length
ENC-CBL-AA5939	1 ft.
ENC-CBL-AA5939-5	5 ft.
ENC-CBL-AA5939-10	10 ft.

NOTE: For pricing and other information on cables and centering tools, please visit Accessories on our website.

Centering Tools:

Centering tools are optional, but recommended for a more precise installation.

ENC-CTOOL - 250

Bore Size	
079=2mm	375=3/8"
118=3mm	394=10mm
125=1/8"	472=12mm
157=4mm	500=1/2"
188=3/16"	551=14mm
197=5mm	625=5/8"
236=6mm	750=3/4"
250=1/4"	787=20mm
276=7mm	875=7/8"
313=5/15"	984=25mm