

Step 1

1. Insert Tool A as a spacer that defines the distance to the mounting surface.
2. Slide appropriate sized Sleeve over shaft all the way down to Tool A.
3. Slide Shaft Adapter over Sleeve.
4. Use Tool B to press Shaft Adapter over Sleeve until flush with Tool A.

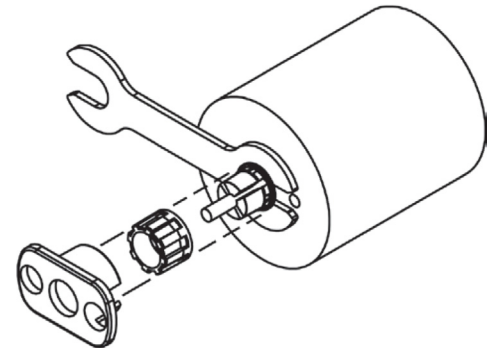

Step 2

1. Remove Tools A and B.
2. Place Base on motor, with Tool B used as a centering tool.

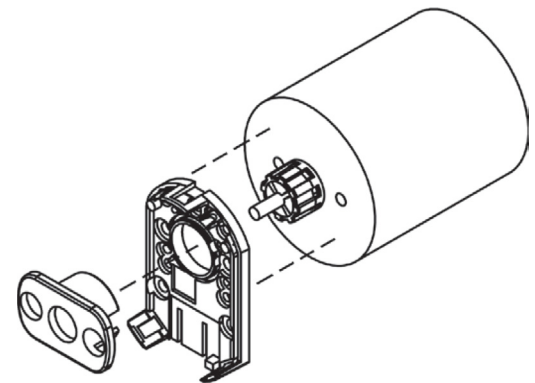

Step 3

1. Align Tool B with flange on Base.
2. Slide Base and Tool B onto motor, centering onto the Shaft Adapter.

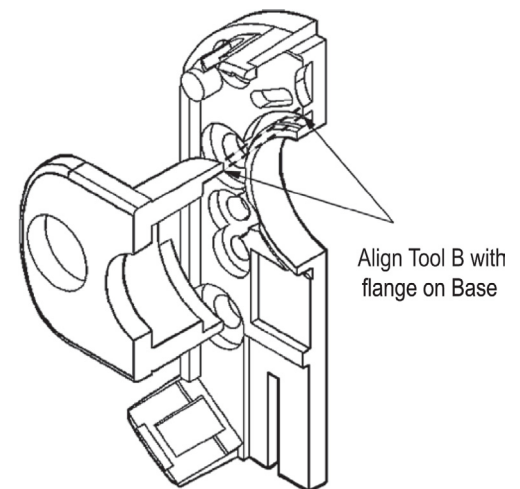

Step 4

1. Fasten the Base on the motor.
2. Remove Tool B.

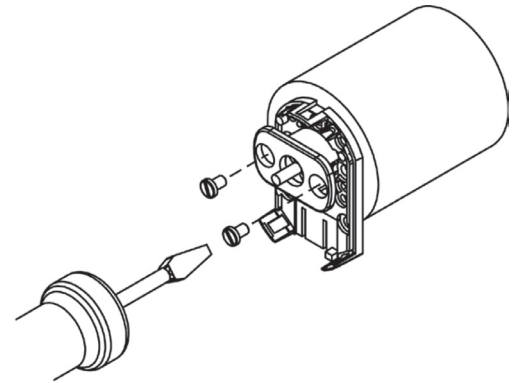

Step 5

1. Slide the Top Cover onto the Base, carefully observing that the teeth of the Shaft Adapter align with the grooves in the hub.*

* We recommend no more than three cycles of mounting and removal of the AMT top cover base. Multiple cycles of mounting and removing the top cover can cause base fatigue over time and affect encoder performance.

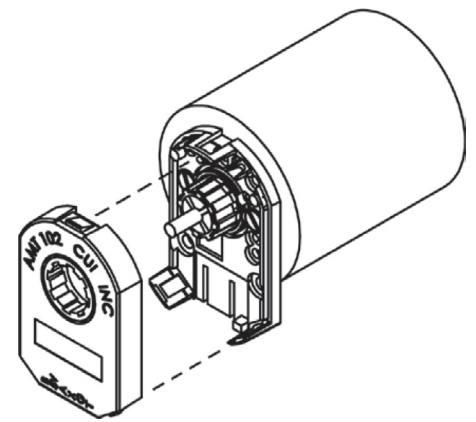

Step 6

1. Make sure the snaps are fully engaged and the Top Cover is flush with the Base.
2. When assembly is finished, the Shaft Adapter should be about flush with the front of the Encoder and the Motor Shaft should rotate freely.

