

ENC-A5SNH High Voltage Single-Ended Encoder



FEATURES

- Powered From a Single 7.5~30VDC Power Supply
- 2-Channel Quadrature Open Collector and TTL Squarewave Outputs
- 32 to 1,250 Cycles Per Revolution (CPR)
- Tracks 0 to 300,000 Cycles Per Second
- Accepts +/- 0.010" Axial Shaft Play
- Operating Temperature, CPR < 2000 is -40° to +100° C
- Operating Temperature, CPR ≥ 2000 is -25° to +100° C
- RoHS Compliant and REACH Certified



DESCRIPTION

The ENC-A5SNH is a high voltage single-ended, transmissive optical encoder module designed to detect the rotary position with a code wheel. The cable driver is built into the encoder and includes a 10-PIN single-ended open collector output. This new output configuration enables Incremental Encoders to accept power up to 30VDC without external adapters. The ENC-A5SNH requires a minimum shaft length of .445" and maximum shaft length of .570", and can be attached to the end of any shaft size ranging from .079" to .394" in diameter to provide digital feedback information. This single-ended encoder consists of a LED source lens and a monolithic detector IC enclosed in a small mance and tolerances over traditional aperture mask type encoders. The ENC-A5SNH series provides digital quadrature squarewave outputs on all resolutions and are capable of sinking or sourcing 8 mA each. These encoders are powered from a single +5VDC power supply.

ORDERING INFORMATION

ENC - A5SNH - 0050 - 394 - H - G

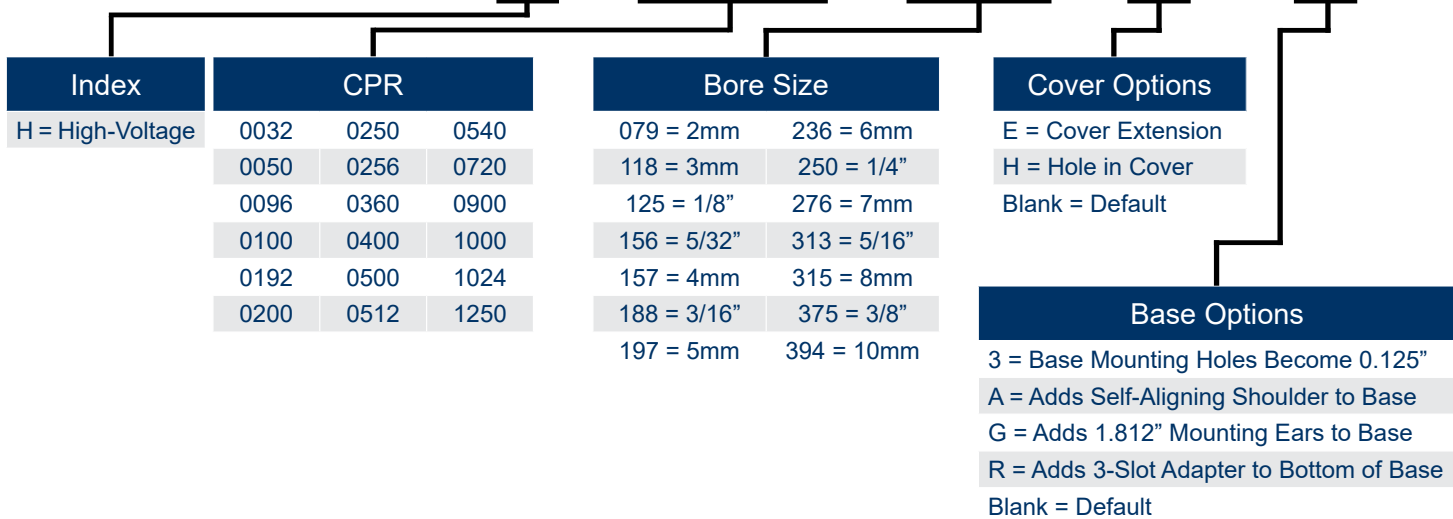

L011963

DEFAULT OPTION:

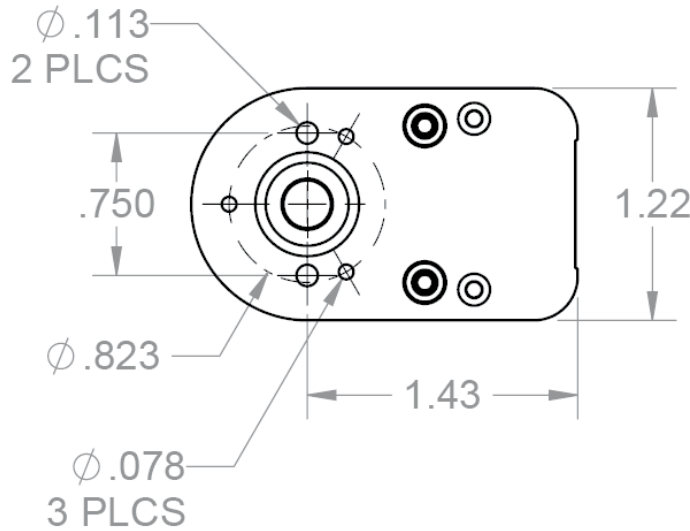

Note: Dimensions are in inches

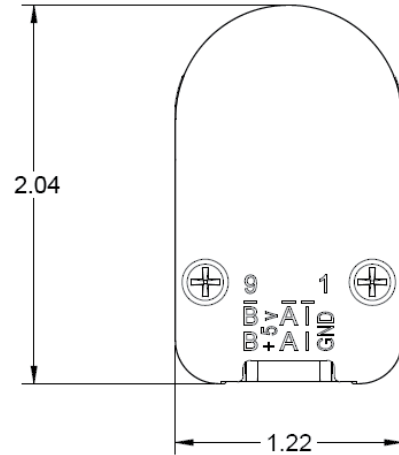

E-Option:

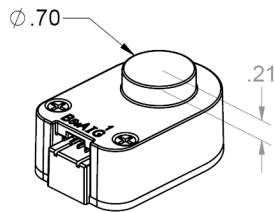

H-Option:

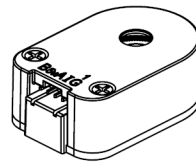

Default Option:

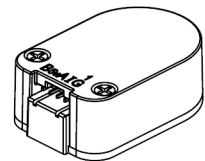

Note: Dimensions are in inches

Cover Options:	Description
E - Option	E-Option provides a cylindrical extension cover for larger shafts. The required shaft length is .445" to .750". Note: E-option + R-Option the required shaft length is .570" to .875".
H - Option	Shafts 2mm to 1/4", a .295" diameter hole is supplied. Shafts 5/16" to 10mm, a .438" diameter hole is supplied. Required shaft length > 0.445" Note: H-Option + R-Option the required shaft length is > .570"
Default Option	The required length is .445" to .570" Note: Default Option + R-Option the required shaft length is .570" to .695"

3-OPTION:

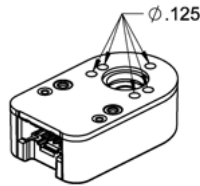

3-Option: Makes all five hole diameters .125"

A-OPTION:

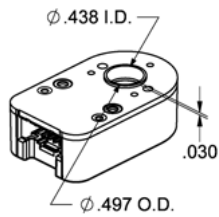

A-Option: Adds a .497" diameter alignment shoulder designed to slip into a .500" diameter recess in the mounting surface centered around the shaft.

R-OPTION:

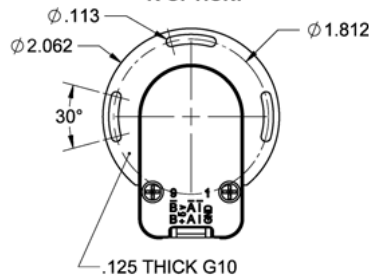

R-Option: Adapter is an 1/8" thick fiberglass adapter which is pre-mounted to the base of the encoder. It allows the encoder to rotate +/- 15 degrees.
*This option adds 1/8" to the required shaft length.

G-OPTION:

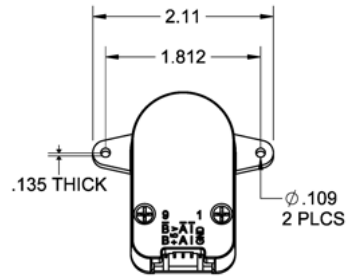

G-Option: Includes molded ears which enables it to be mounted to a 1.812" diameter bolt circle. Mounting holes are designed to fit 4-40 screws. Will work with shaft lengths of .445" to .570" and does not add to the required shaft length.

Note: All dimensions are in inches

(Note: Base Mounting Screws are NOT included. #2-56 or #4-40 screws can be used to mount the base to your mounting surface.)

SINGLE-ENDED ENCODER PINOUT
TOP OF ENCODER FACING PLUG

Pin #	Function
1	Ground
2	Ground
3	Index- (open collector)
4	Index+ (single-ended)
5	A- channel (open collector)
6	A+ channel (single-ended)
7	7.5-30V power
8	7.5-30V power
9	B- channel (open collector)
10	B+ channel (single-ended)

Timing Characteristics	Symbol	Min	Typ	Max	Units
Cycle Error	C	-	3.0	5.5	°e
Symmetry	X,Y	150	180	210	°e
Quadrature	Z	60	90	120	°e
Index Pulse Width	Po	60	90	120	°e
Ch. I Rise After Ch. B or Ch. A Fall	t1	10	100	250	ns
Ch. I Fall After Ch. B or Ch. A Rise	t2	70	150	300	ns

SINGLE-END ENCODER TIMING DIAGRAMS

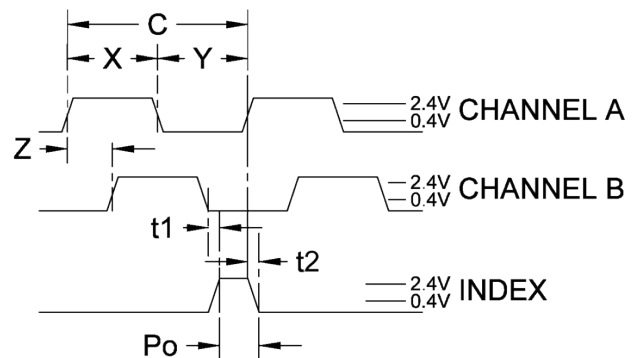

ROTATION:
CW - A LEADS B, CCW - B LEADS A

Terminology	Description
CPR(N):	The Number of Cycles Per Revolution
One Shaft Rotation:	360 mechanical degrees, N cycles
One Electrical Degree (°e):	1/360th of one cycle
One Cycle (C):	360 electrical degrees (°e). Each cycle can be decoded into 1 or 4 codes, referred to as X1 or X4 resolution multiplication
Symmetry:	A measure of the relationship between (X) and (Y) in electrical degrees, nominally 180 °e
Quadrature (Z):	The phase lag or lead between channels A and B in electrical degrees, nominally 90 °e
Index (CH I):	The Index Output goes high once per revolution, coincident with the low states of channels A and B, nominally 1/4 of one cycle (90°e)

Recommended Operating Conditions	Min	Max	Units
Temperature (CPR < 2000)	-40	100	°C
Temperature (CPR ≥ 2000)	-25	100	°C
Load Capacitance	-	100	pF
Count Frequency (CPR ≤ 1250)	-	300	kHz
Count Frequency (CPR 2000-2500)	-	360	kHz
Count Frequency (CPR 4000+)	-	720	kHz

Parameter	Max	Units
Vibration (5 to 2kHz)	20	g
Shaft Axial Play	+/- 0.01	in.
Shaft Eccentricity Plus Radial Play	0.004	in.
Acceleration	250,000	rad/sec ²

Parameter	Min	Typ	Max	Units
Supply Voltage	7.5		30.0	Volts
Supply Current				
CPR < 500, no load	-	8	10	mA
CPR ≥ 500 and < 2000, no load	-	16	19	
CPR ≥ 2000, no load	-	22	25	

Open Collector Parameters	Min	Typ	Max	Units
Open Collector "On" Resistance		2		ohms
Open Collector Sink Current			200	mA
Output Low Voltage		0.4		Volts 200 mA sink current
Open Collector Pullup Voltage		50		Volts

TTL Parameters	Min	Typ	Max	Units
Output Low				
I _{OL} = 8mA max (CPR < 2000)	-	-	0.5	Volts
I _{OL} = 5mA max (CPR ≥ 2000)	-	-	0.5	
no load (CPR ≥ 2000)	-	0.25	-	

Output High*				
I _{OL} = -8mA max (CPR < 2000)	2.0	-	-	Volts
I _{OL} = -5mA max (CPR ≥ 2000)	2.0	-	-	
no load (CPR < 2000)	-	4.8	-	
no load (CPR ≥ 2000)	-	3.5	-	

Output Current Per Channel (CPR < 2000)	-8.0	-	8.0	mA
---	------	---	-----	----

Output Current Per Channel (CPR ≥ 2000)	-5.0	-	5.0	mA
--	------	---	-----	----

Output Rise Time (CPR < 2000)	-	110	-	nS
---	---	-----	---	----

Output Rise Time (CPR ≥ 2000), ± 5mA load	-	50	-	
--	---	----	---	--

Output Fall Time (CPR < 2000)	-	110	-	
---	---	-----	---	--

Output Fall Time (CPR ≥ 2000), ± 5mA load	-	50	-	nS
--	---	----	---	----

* Unloaded high level output voltage is 4.80V typically, 4.2V minimum.

Speed Calculation		Units
CPR ≤ 1250	18x10 ⁶ / CPR	RPM
CPR 2000-2500	21.6x10 ⁶ / CPR	RPM
CPR 4000+	43.2x10 ⁶ / CPR	RPM

*60,000 RPM is the maximum RPM due to mechanical limitations.

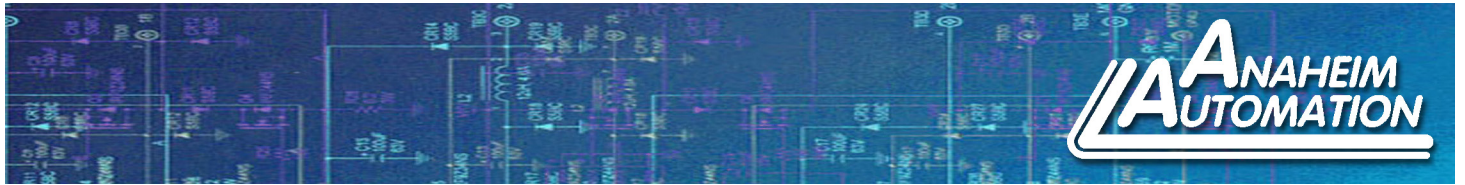

Cables:

The following cables are compatible with Anaheim Automation's A5SIH series encoder. Select a cable length from the table below:

Cable Part Number	Length
ENC-CBL-AA4707	1 ft.
ENC-CBL-AA4707-5	5 ft.
ENC-CBL-AA4707-10	10 ft.

NOTE: For pricing and other information on cables and centering tools, please visit Accessories on our website.

Centering Tools:

Centering tools are optional, but recommended for a more precise installation.

ENC-CTOOL - 250

Bore Size	
079=2mm	236=6mm
118=3mm	250=1/4"
125=1/8"	276=7mm
157=4mm	313=5/15"
188=3/16"	375=3/8"
197=5mm	394=10mm