

ENC-A6SNH High Voltage Single-Ended Optical Kit Encoder



FEATURES

- Powered From a Single 7.5~30VDC Power Supply
- 2-Channel Quadrature Open Collector and TTL Squarewave Outputs
- 64 to 10,000 Cycles Per Revolution (CPR)
- Positive Latching Connector
- Allows for ±0.010" Axial Shaft Play
- Operating Temperature, CPR < 2000 is -40° to +100° C
- Operating Temperature, CPR ≥ 2000 is -25° to +100° C
- RoHS Compliant and REACH Certified



DESCRIPTION

The ENC-A6SNH is a Single-Ended Optical Kit Encoder designed for quick and simple assembly that fits any shaft diameters from 0.079" to 1". It fits to any shaft length over 0.445" diameter when equipped with the Hole in Cover option. However, the default required shaft length is from 0.445" to 0.570" and the Cover Extension required shaft length is 0.445" to 0.750". The cable driver is built into the encoder and includes a 10-PIN single-ended open collector output. This new output configuration enables Incremental Encoders to accept power up to 30VDC without external adapters. The ENC-A6SNH module is designed to detect the rotary position with a code wheel. The ENC-A6SNH can be attached to any existing shaft to provide digital feedback information. This Single-Ended Encoder consists of a highly accurate aligned solid state light source and monolithic phased array sensor, when combined together they provide a system extremely tolerant to mechanical misalignments. The ENC-A6SNH Single-Ended Optical Kit Encoder has a molded, rugged 20% glass filled polycarbonate that utilizes a 5-Pin latching connector.

ORDERING INFORMATION

ENC - A6SNH - 0100 - 079 - H - M

Index	CPR		Bore Size		Cover Options
N = No Index	0064	1024	079 = 2mm	375 = 3/8"	E = Cover Extension (1)
	0100	1800	118 = 3mm	394 = 10mm	H = Hole in Cover
H = High Voltage	0200	2000	125 = 1/8"	472 = 12mm	Blank = Default
	0400	2048	156 = 5/32"	500 = 1/2"	
	0500	2500	157 = 4mm	551 = 14mm	
	0512		188 = 3/16"	625 = 5/8"	
	1000		197 = 5mm	750 = 3/4"	
			236 = 6mm	787 = 20mm	
			250 = 1/4"	875 = 7/8"	
			313 = 5/16"	984 = 25mm	
			315 = 8mm	1000 = 1"	

Base Options
3 = 0.125" Diameter for Three Base Mounting Holes (2)
M = Adds 4-Hole Mounting Adapter Plate
Blank = Default

(1) With Cover Extension "E" must choose bore size 079 (2mm) to 394 (10mm)
 (2) With Base Option "3" must choose bore size 079 (2mm) to 394 (10mm)

L011965

Default Cover and Base Option

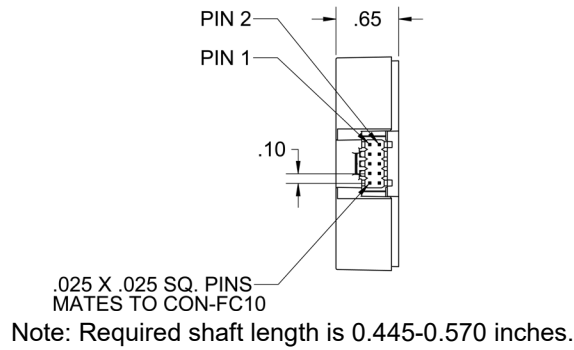
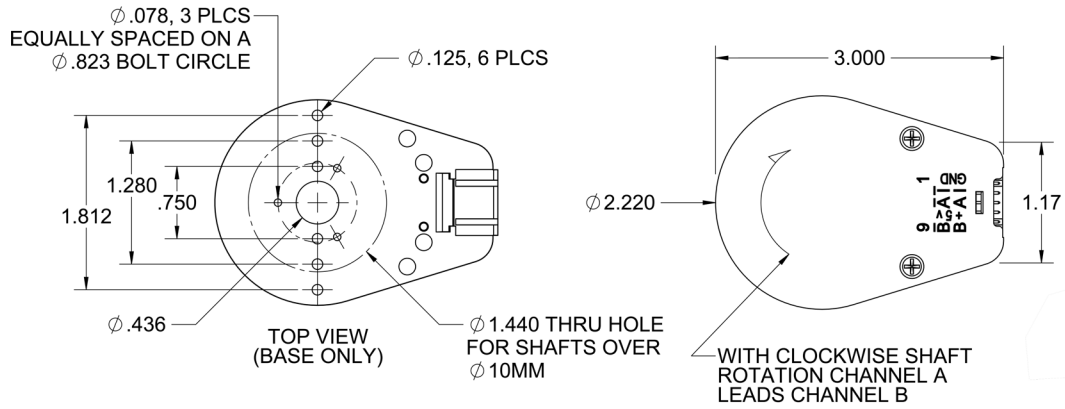

E - Option

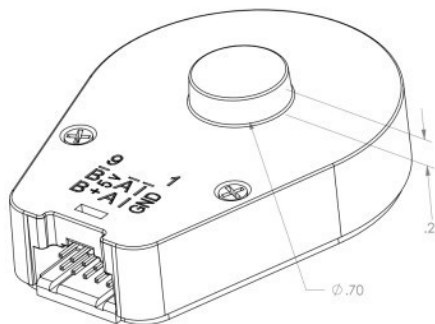

H option thru hole

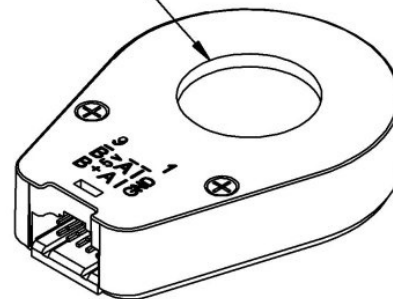

Cover Options:	Description
E - Option	E-Option provides a cylindrical extension cover for longer shafts of up to .750". The required shaft length is .445" to .750".
H - Option	H-Option adds a hole to the cover for the shaft to pass through. Shafts 2mm to 10mm, a .438" diameter hole is supplied. Shafts 12mm to 1", a 1.047" diameter hole is supplied.

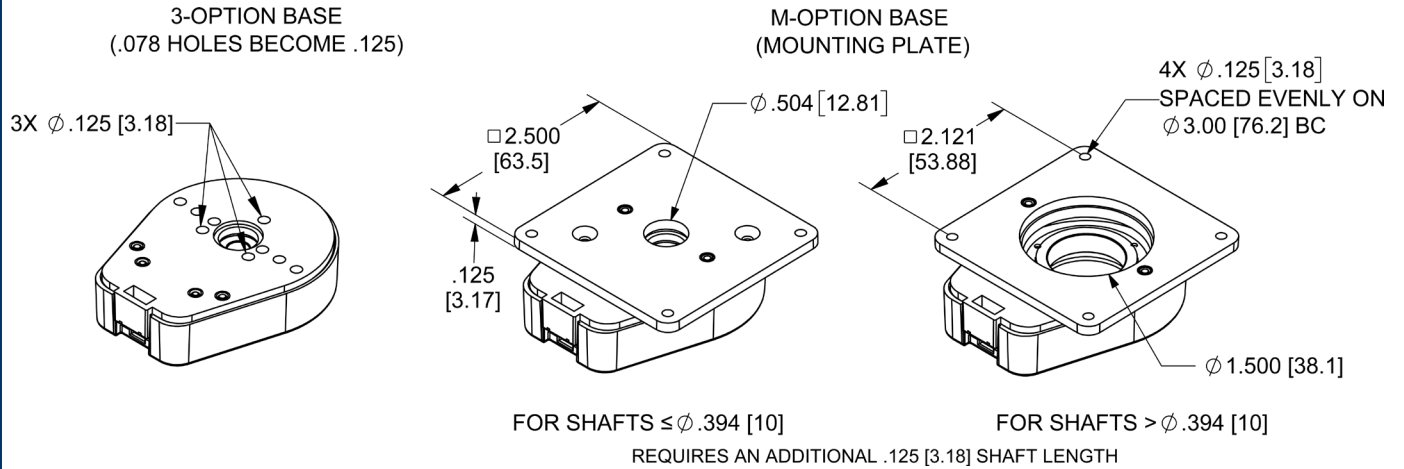

Base Options:	Description
3 - Option	3-Option makes three of these hole diameters .125"
M - Option	M-Option, this adapter plate is for mounting to a 3" diameter bolt circle.

(Note: Base Mounting Screws are NOT included. #2-56 or M2.5 #4-40 screws can be used to mount the base to your mounting surface.)

SINGLE-ENDED ENCODER PINOUT
TOP OF ENCODER FACING PLUG

Pin #	Function
1	Ground
2	Ground
3	Index- (open collector)
4	Index+ (single-ended)
5	A- channel (open collector)
6	A+ channel (single-ended)
7	7.5-30V power
8	7.5-30V power
9	B- channel (open collector)
10	B+ channel (single-ended)

Timing Characteristics	Symbol	Min	Typ	Max	Units
Cycle Error	C	-	3.0	5.5	°e
Symmetry	X,Y	150	180	210	°e
Quadrature	Z	60	90	120	°e
Index Pulse Width	Po	60	90	120	°e
Ch. I Rise After Ch. B or Ch. A Fall	t1	10	100	250	ns
Ch. I Fall After Ch. B or Ch. A Rise	t2	70	150	300	ns

SINGLE-END ENCODER TIMING DIAGRAMS

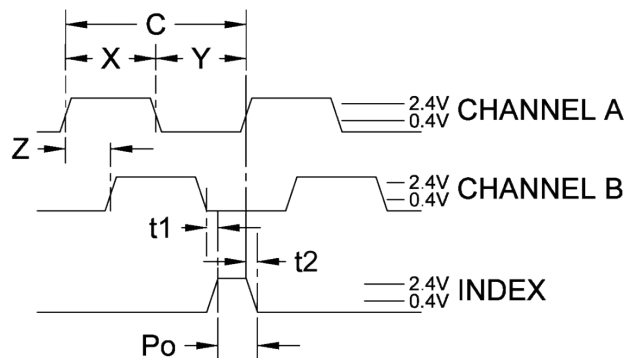

ROTATION:
CW - A LEADS B, CCW - B LEADS A

Terminology	Description
CPR(N):	The Number of Cycles Per Revolution
One Shaft Rotation:	360 mechanical degrees, N cycles
One Electrical Degree (°e):	1/360th of one cycle
One Cycle (C):	360 electrical degrees (°e). Each cycle can be decoded into 1 or 4 codes, referred to as X1 or X4 resolution multiplication
Symmetry:	A measure of the relationship between (X) and (Y) in electrical degrees, nominally 180 °e
Quadrature (Z):	The phase lag or lead between channels A and B in electrical degrees, nominally 90 °e
Index (CH I):	The Index Output goes high once per revolution, coincident with the low states of channels A and B, nominally 1/4 of one cycle (90°e)

Recommended Operating Conditions	Min	Max	Units
Temperature (CPR < 2000)	-40	100	°C
Temperature (CPR ≥ 2000)	-25	100	°C
Load Capacitance	-	100	pF
Count Frequency (CPR ≤ 1250)	-	300	kHz
Count Frequency (CPR 2000-2500)	-	360	kHz
Count Frequency (CPR 4000+)	-	720	kHz

Parameter	Max	Units
Vibration (5 to 2kHz)	20	g
Shaft Axial Play	+/- 0.01	in.
Shaft Eccentricity Plus Radial Play	0.004	in.
Acceleration	250,000	rad/sec ²

Parameter	Min	Typ	Max	Units
Supply Voltage	7.5		30.0	Volts
Supply Current				
CPR < 500, no load	-	8	10	mA
CPR ≥ 500 and < 2000, no load	-	16	19	
CPR ≥ 2000, no load	-	22	25	

Open Collector Parameters	Min	Typ	Max	Units
Open Collector "On" Resistance		2		ohms
Open Collector Sink Current			200	mA
Output Low Voltage		0.4		Volts 200 mA sink current
Open Collector Pullup Voltage		50		Volts

TTL Parameters	Min	Typ	Max	Units
Output Low				
I _{OL} = 8mA max (CPR < 2000)	-	-	0.5	Volts
I _{OL} = 5mA max (CPR ≥ 2000)	-	-	0.5	
no load (CPR ≥ 2000)	-	0.25	-	

Output High*				
I _{OL} = -8mA max (CPR < 2000)	2.0	-	-	Volts
I _{OL} = -5mA max (CPR ≥ 2000)	2.0	-	-	
no load (CPR < 2000)	-	4.8	-	
no load (CPR ≥ 2000)	-	3.5	-	

Output Current Per Channel (CPR < 2000)	-8.0	-	8.0	mA
---	------	---	-----	----

Output Current Per Channel (CPR ≥ 2000)	-5.0	-	5.0	mA
--	------	---	-----	----

Output Rise Time (CPR < 2000)	-	110	-	nS
---	---	-----	---	----

Output Rise Time (CPR ≥ 2000), ± 5mA load	-	50	-	
--	---	----	---	--

Output Fall Time (CPR < 2000)	-	110	-	
---	---	-----	---	--

Output Fall Time (CPR ≥ 2000), ± 5mA load	-	50	-	nS
--	---	----	---	----

* Unloaded high level output voltage is 4.80V typically, 4.2V minimum.

Speed Calculation		Units
CPR ≤ 1250	18x10 ⁶ / CPR	RPM
CPR 2000-2500	21.6x10 ⁶ / CPR	RPM
CPR 4000+	43.2x10 ⁶ / CPR	RPM

*60,000 RPM is the maximum RPM due to mechanical limitations.

Cables:

The following cables are compatible with Anaheim Automation's A5SIH series encoder. Select a cable length from the table below:

Cable Part Number	Length
ENC-CBL-AA4706	1 ft.
ENC-CBL-AA4706-5	5 ft.
ENC-CBL-AA4706-10	10 ft.
ENC-CBL-AA4706-20	20 ft.

NOTE: For pricing and other information on cables and centering tools, please visit Accessories on our website.

Centering Tools:

Centering tools are optional, but recommended for a more precise installation.

ENC-CTOOL - 250

Bore Size	
079=2mm	236=6mm
118=3mm	250=1/4"
125=1/8"	276=7mm
157=4mm	313=5/15"
188=3/16"	375=3/8"
197=5mm	394=10mm