

GBP NR-080x-CS Series



FEATURES

- Gear Ratios From 3 to 512
- Backlash Lower Than 17 arc-min
- Available in 1, 2 and 3 Stage Models
- Lifetime Lubrication
- High Durability

DESCRIPTION

The GBP NR-080x-CS Series right angle planetary gearbox offers you the precision you need at the prices you want! This right angle planetary gearbox is designed with very low backlash for motion control, automation, and robotic applications requiring precise position requirements. This right angle planetary gearbox will match your servo or stepping motor. It comes in 22 different gear ratios. Built with the design goal of offering a cost-effective product without sacrificing quality, you will find that this right angle planetary gearbox offers you an extraordinary value.

DIMENSIONS

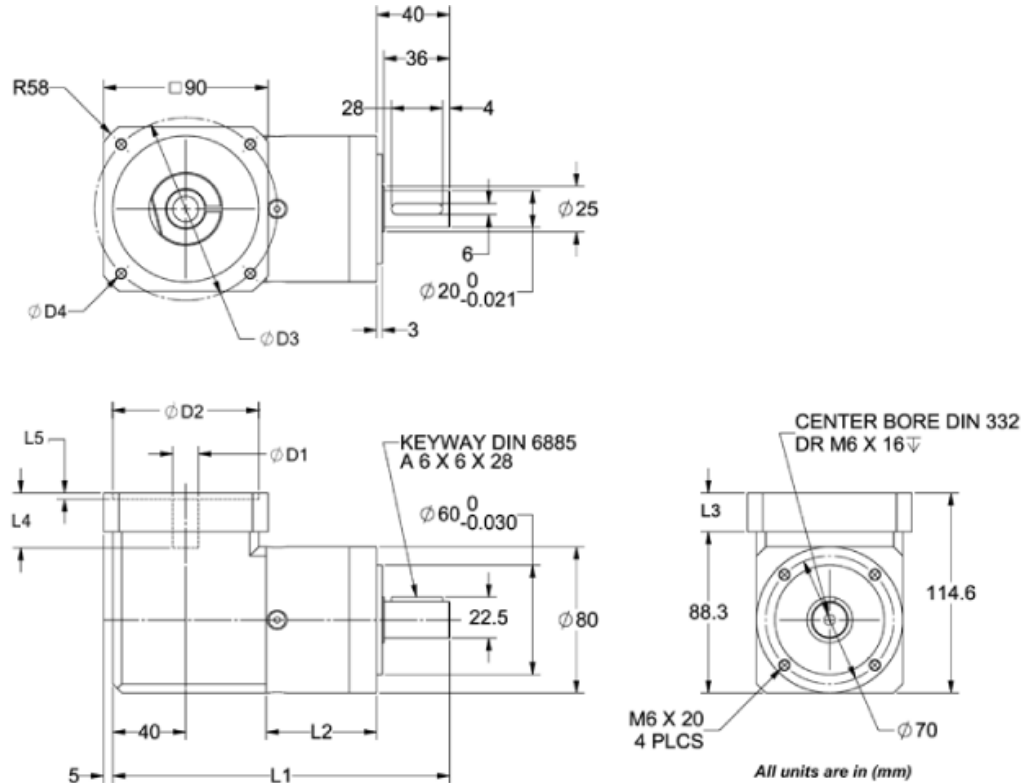

ITEM	DESCRIPTION	MOTOR INTERFACE			
		AA341-500	AA341-625	BLK32-748	SMH80-748
D1	Input Shaft Diameter	12.7	15.875	19	19
L4	Max Shaft Length	35	35	47	47
L3	Motor Mount Length	26.5	26.5	31.2	31.2
D2	Pilot Diameter	73.025	73.025	70	70
L5	Pilot Depth	5.3	5.3	5.3	5.3
D3	Mounting Bolt Hole Circle	98.4	98.4	90	90
D4	Bolt Hole Size	M5x12	M5x12	M6x15	M6x15

L010522

Model #	Gear Ratio	Nominal Rated Torque (oz-in)	Max Torque (oz-in)	Stages	Backlash Maximum (arcmin)	L1 Length (mm)	L2 Length (mm)	Weight (lbs)
GBPNR-0801-CS-003-xxxx-yyy	3	5664	9056	1	<13	184	61	9.7
GBPNR-0801-CS-004-xxxx-yyy	4	7504	12032	1	<13	184	61	9.7
GBPNR-0801-CS-005-xxxx-yyy	5	9472	15136	1	<13	184	61	9.7
GBPNR-0801-CS-008-xxxx-yyy	8	7072	11328	1	<13	184	61	9.7
GBPNR-0802-CS-009-xxxx-yyy	9	18400	29440	2	<15	202	78	11.2
GBPNR-0802-CS-012-xxxx-yyy	12	16992	27184	2	<15	202	78	11.2
GBPNR-0802-CS-015-xxxx-yyy	15	15568	24928	2	<15	202	78	11.2
GBPNR-0802-CS-016-xxxx-yyy	16	16992	27184	2	<15	202	78	11.2
GBPNR-0802-CS-020-xxxx-yyy	20	16992	27184	2	<15	202	78	11.2
GBPNR-0802-CS-025-xxxx-yyy	25	15568	24928	2	<15	202	78	11.2
GBPNR-0802-CS-032-xxxx-yyy	32	16992	27184	2	<15	202	78	11.2
GBPNR-0802-CS-040-xxxx-yyy	40	15568	24928	2	<15	202	78	11.2
GBPNR-0802-CS-064-xxxx-yyy	64	7072	11328	2	<15	202	78	11.2
GBPNR-0803-CS-060-xxxx-yyy	60	15568	24928	3	<17	219	95	12.1
GBPNR-0803-CS-080-xxxx-yyy	80	16992	27184	3	<17	219	95	12.1
GBPNR-0803-CS-100-xxxx-yyy	100	16992	27184	3	<17	219	95	12.1
GBPNR-0803-CS-120-xxxx-yyy	120	15568	24928	3	<17	219	95	12.1
GBPNR-0803-CS-160-xxxx-yyy	160	16992	27184	3	<17	219	95	12.1
GBPNR-0803-CS-200-xxxx-yyy	200	15568	24928	3	<17	219	95	12.1
GBPNR-0803-CS-256-xxxx-yyy	256	16992	27184	3	<17	219	95	12.1
GBPNR-0803-CS-320-xxxx-yyy	320	15568	15568	3	<17	219	95	12.1
GBPNR-0803-CS-512-xxxx-yyy	512	7072	7072	3	<17	219	95	12.1

Part numbers are based on the specifications of the motor being matched to the gearbox.

-xxxxx denotes motor pilot, -yyy denotes input shaft diameter.

For more information contact an Anaheim Automation Applications Engineer for assistance.

Radial Load:	213 lbs - Force	Axial Load:	269 lbs - Force
Operating Temperature:	-25° C - 90°C	Noise Level:	73 dB
Maximum Input Speed:	7,000 RPM	Design Life:	20,000 hours
Efficiency:	88% - 94%	IP Rating:	IP 54 / 55