

KNC-HMI-G070 Series



FEATURES

- Ethernet/CAN Open models available
- 16.77m (24 Bits) True Color
- 32-Bit 800 MHz ARM RISC CPU
- Real-Time Clock, Reserve Time for More than 2 Years at Power Off State
- 3 COM Ports, Supports RS232/RS485/RS422
- 24 VDC Input Voltage
- CE Certified / UL Listed File No. E344264
- 128MB NAND FLASH + 128MB DDR3 Memory



DESCRIPTION

The Green Series G070 is the most modern and powerful HMI product that will make your application work seamlessly, without missing a step. The G070 Series has a new structure and elegant body, compared to previous HMI's. This HMI line comes with a 16.77 million Color Display mode that gives your touch screen rich color and incomparable resolution. The Green Series products use the most advantageous ARM Cortex-A7 architecture industrial-grade processors, which ensure that the HMI's work efficiently. Each HMI supports simultaneous communications via its multiple serial ports, so that you can connect to different controllers and PLCs at the same time. With the simple, convenient and powerful DTools configuration software, the user can master its design method and create first-class programs efficiently.

DIMENSIONS

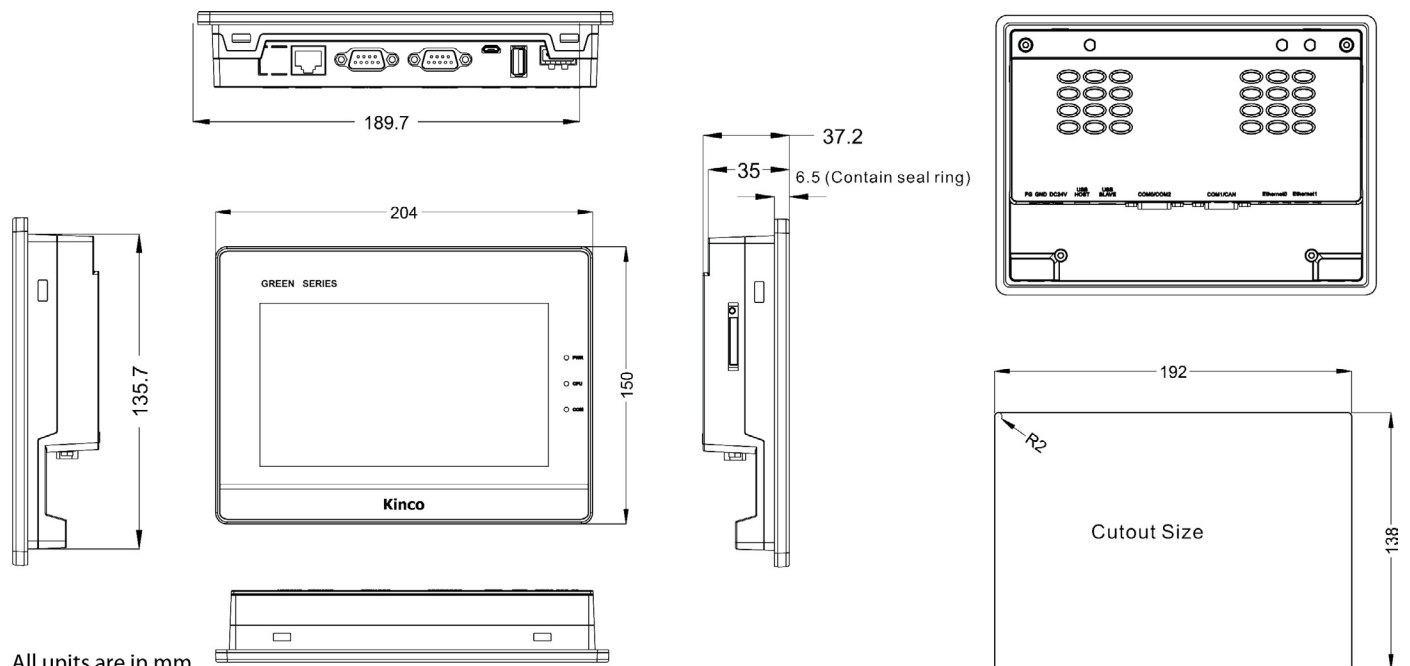

L011771

KNC-HMI-G070 Series



SPECIFICATIONS

MODEL	G070	G070E	G070E-CAN
Performance Specification			
Display	7" TFT		
Display Area	154.08 (W) x 85.92 (H) (mm)		
Resolution	800x480 pixel		
Display Color	16.77 Million True Color		
Backlight	LED		
Brightness	400cd/m2		
Backlight Life	More than 30000 Hours		
Touch Panel	4 Wire Precision Resistance Network (Surface Hardness 4H)		
CPU	ARM RISC 32Bit 800MHz		
Storage	128MB NAND Flash Memory + 128MB DDR3 Memory		
RTC	Built-in		
Expandable Memory	1 USB Host		
Print Port	USB Host/Serial Port		
Ethernet	None	10/100MHz Adaptable Ethernet Interface	10/100MHz Adaptable Ethernet Interface
Bus Interface	None	None	1*CANopen
Program Download	USB Slave Micro / USB Flash Drive	USB Slave Micro / USB Flash Drive / Ethernet	USB Slave Micro / USB Flash Drive / Ethernet
Communication Port	COM0:RS232/RS485/RS422; COM1:RS485; COM2:RS232		
Electrical Specification			
Input Power Supply	DC12V ~ DC28V, Built-in Isolation Power Supply		
Power Input	3.8W		
Allowable Loss of Power	<3ms		
Insulation Resistance	Over 50MΩ@500VDC		
Hi-pot Test	500 VAC 1 Minute		
Structure Specification			
Shell Material	Engineering Plastic		
Shape Size	204 x 150 x 34 (mm)		
Installation Hole Size	192 x 138 (mm)		
Weight	1.1 lbs		
Environment Specification			
Working Temperature	0 ~ 50°C		
Working Humidity	10 ~ 90%RH (non-condensing)		
Storage Temperature	-20 ~ 60°C		
Storage Humidity	10 ~ 90%RH (non-condensing)		
Vibration Test	10 ~ 500Hz (X, Y, Z direction 2G/30 minute)		
Cooling Mode	Natural Air Cooling		
Certification			
Panel Protection Grade	Conforming to IP65 Certification(4208-93)		
CE Certification	EN6100-6-4:2007, EN61000-6-2:2005		
UL Listed	File #: E344264		
Software			
Configuration Software	Kinco DTools V3.2 and Above		

1. Installation Note

1.1 Environment Requirement

Operating temperature: G070/G070E/G070E-CAN HMI can work stably in most industrial environments when the temperature is between 32°F to 122°F (0~50°C).

NEMA rating: HMI front panel is NEMA1 rated.

Do not install this HMI in the following environments:

- Areas with direct sunlight
- Environments where the surrounding temperature or humidity exceed specifications
- Areas with high condensation. Avoid areas where temperature changes dramatically or sharply, as these changes can cause condensation
- Areas with corrosive or combustible gas
- Environments where dust, dirt, salt, or iron powder are present
- Avoid water, oil, and vapor
- Areas in which the HMI will be subject to vibration or shock

Take shielding measures in the following locations:

- Anywhere electrostatic noise or electromagnetic noise is present
- Any location where X-rays or microwaves are present
- Near power sources

1.2 Power Requirement

- Input Voltage: DC12V~DC28V
- Maintain sufficient distance between the HMI and any converters or switching mode power supplies. Ensure that the input and output cables of such equipment are shielded cables, and that the shielding network is properly connected to ground.
- Ensure that the DC power and AC power are isolated

Note: An internal fuse will prevent damage for over-voltage, but does not guarantee protection against damage of internal electronic components.

2. Installation Description

2.1 Dimensional Drawing

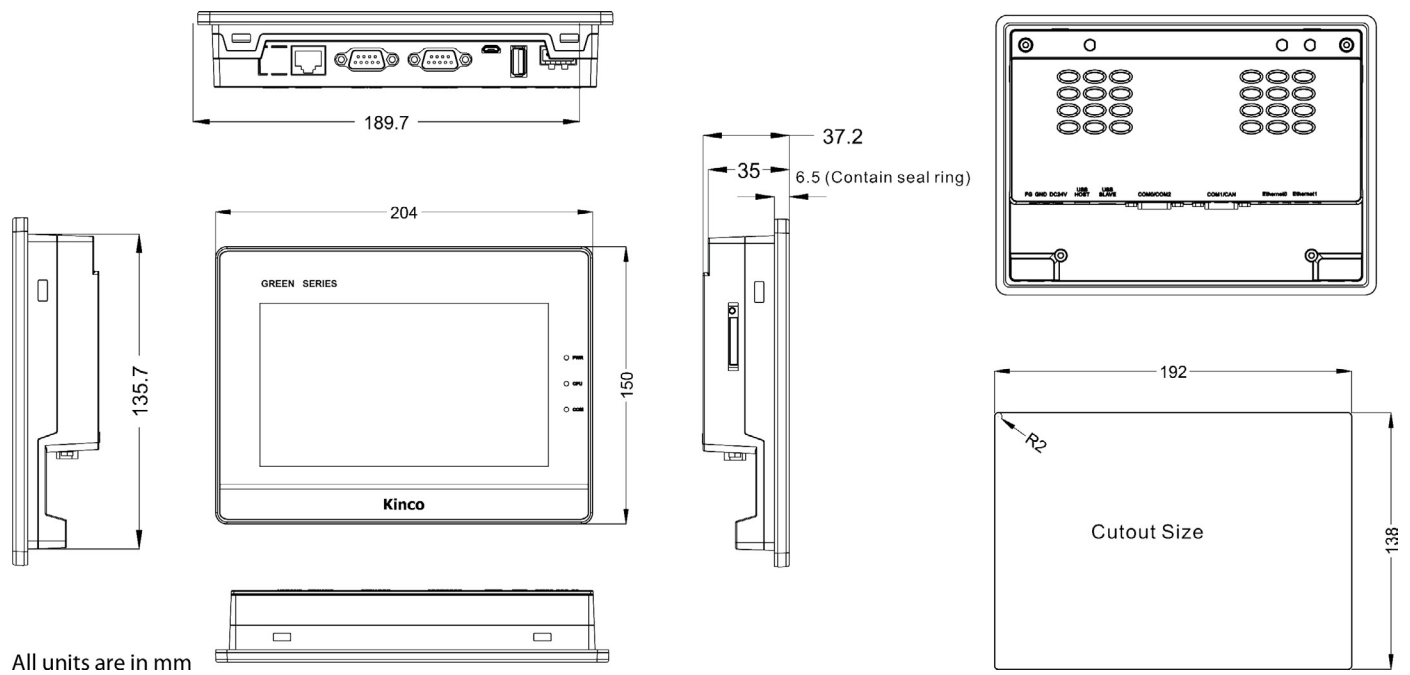

2.2 Fixed Screw Installation Instructions

The product is placed into the cut out of the machine control box's panel, and the mounting screws are inserted into the fixing holes around the HMI shell from the back of the control box's panel. Recommended lock torque: 0.5N.m (for waterproof effect and to avoid shell deformation)

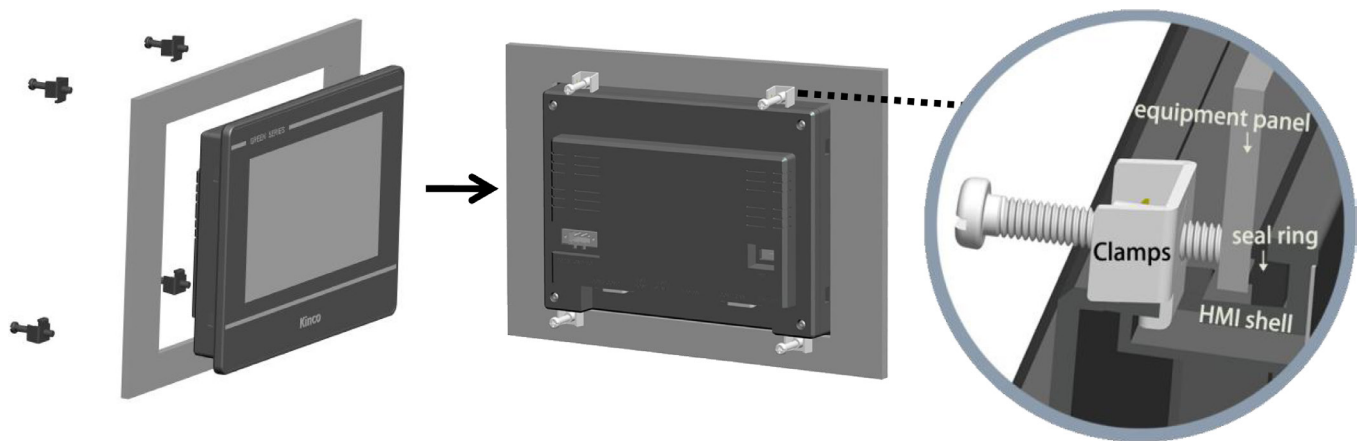

2.3 Power Connection

Before connecting the power, please make sure all local and national electrical standards are met. For power cables, please select cables with their dielectric strength values and current values in compliance with the safety specifications. First, find the power terminal at the back of the product and loosen the screw, by turning it counterclockwise. Then, insert the power cables and tighten the screw. Connect positive DC line to the 'DC24V' terminal, the DC ground to the 'GND' terminal and the earth or machine ground line to the 'FG' terminal.

3. External Interface

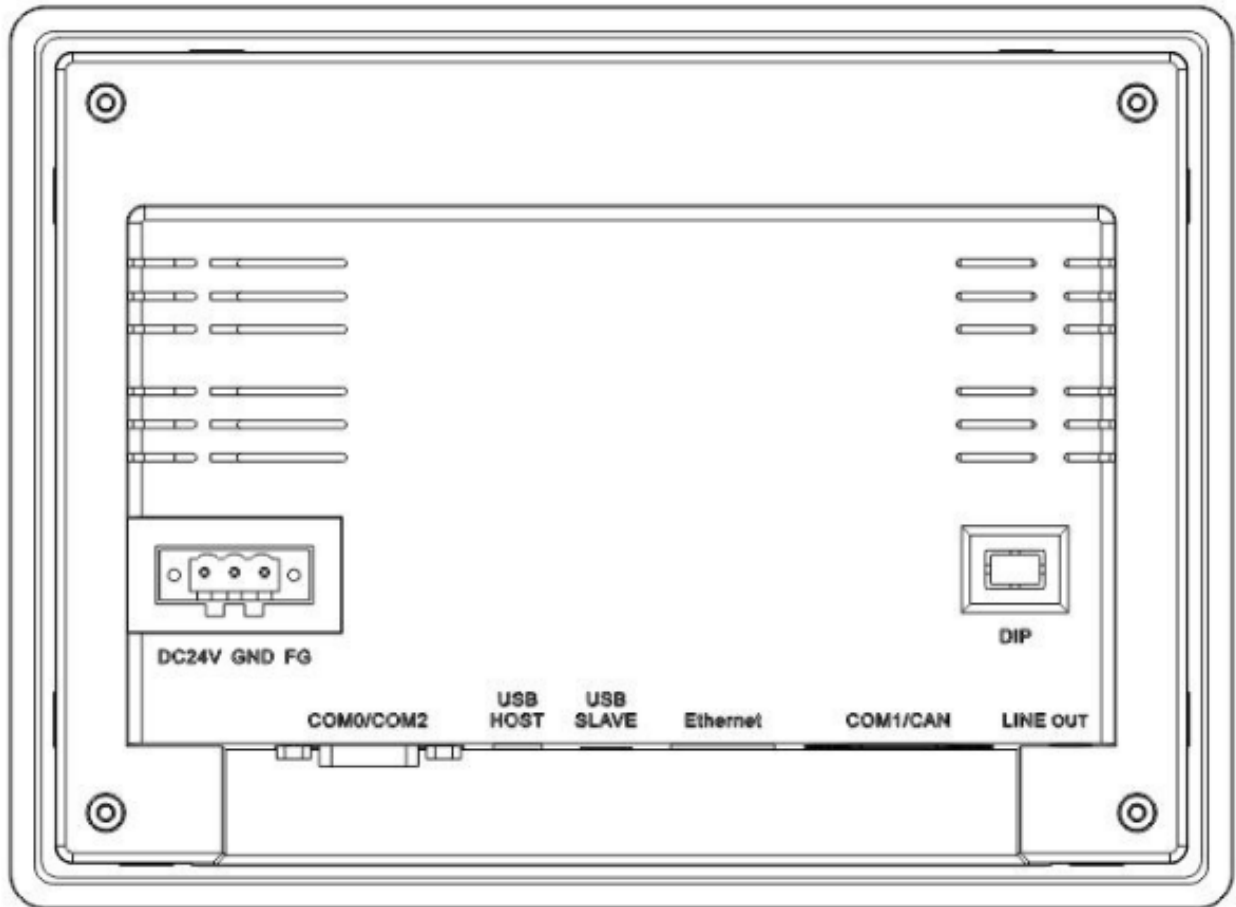

3.1 Power

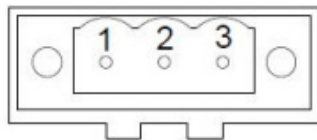

Pin	Signal
1	DC24V
2	GND
3	FG

3.2 COM0/COM2

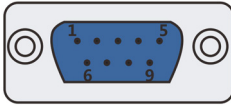

Pin assignment of the 9-pin male, D-SUB, COM0/COM2. Note: RS232/485/422 communication functions are supported by COM0. COM2 supports RS232 communication function.

Pin	Signal	PLC (COM0) [RS-422]	PLC (COM0) [RS-485]	PLC (COM0) [RS-232]	PC/PLC (COM2) [RS-232]
1	Rx- (B)	RS422 R-	RS485 B		
2	RxD_PLC			RS232 RxD	
3	TxD_PLC			RS232 TxD	
4	Tx-	RS422 T-			
5	GND	Signal Ground			
6	Rx+ (A)	RS422 R+	RS485 A		
7	RxD_PC				RS232 RxD
8	TxD_PC				RS232 TxD
9	Tx+	RS422 T+			

3.3 USB HOST

Connection	Connect with USB interface devices or USB Flash Drives.
Port Function	This interface can be connected with USB keyboard, mouse and printers, and the USB Flash Drives can be used for user's configuration uploading/downloading as well as data storage.

3.4 USB SLAVE

The interface type is MicroUSB

Connection	USB Slave port can be connected with a PC.
Port Function	The port is only used to download the user configuration program to the HMI and to set HMI system parameters.

3.5 Ethernet (G070E/G070E-CAN support)

10M/100M adaptive Ethernet RJ45 port

Connection	With CAT5 UTP cable connected to the Ethernet device.
Port Function	The port can be used for upload/download of HMI configuration, setting of system parameters and online simulations of configurations. It can connect multiple HMIs via the Ethernet to form an HMI network. Furthermore, it can implement communications between the HMI and PLC via the Ethernet, as well as communications with a PC via the Ethernet port.

3.6 COM1/CANbus (CANbus port Only G070E-CAN support)

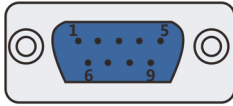

Pin assignment of the 9-pin male, D-SUB, COM1/CANbus. Note: COM1 supports RS485 communication function. HMI can be connected to CANbus network and exchange data with other equipment.

Pin	Signal	COM1 [RS-485]	CANbus (Built-in isolation)
1	Rx- (B)	RS485 B	
2	CAN1_L		CAN1_L
3	CAN_GND		Signal Ground (CAN)
5	GND	Signal Ground	
6	Rx+ (A)	RS485 A	
7	CAN1_H		CAN1_H