

TBI Ball Screw Support Units

EK Series



FEATURES

- Fixed-Side Rectangular Type
- Ball Screw Diameter: 10mm to 30mm
- Input Shaft Diameter: 8mm to 20mm
- Allowable Axial Load: Up to 691Kgf
- Allowable Static Load: Up to 710Kgf
- Maximum Speed: Up to 16,800RPM
- Applicable Screw Accuracy: C3, C5, or C7
- Low Profile Design
- Black Oxide Surface Treatment

DESCRIPTION

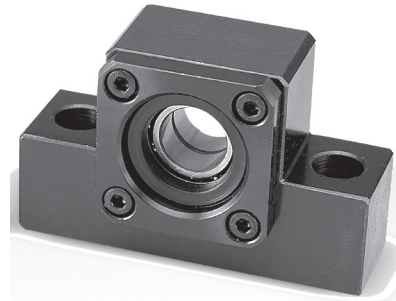

The Rectangular-Type EK Fixed-Side Support Unit Series are available to fit input shaft diameters ranging from 8mm to 20mm. These support units are compact in size and allow for easy installation. All support units come with angular contact bearings which are assembled with the correct preload and amount of lubrication. These support units have an allowable axial load up to 587Kgf, allow static load up to 762.2Kgf, and can handle speeds up to 28,000RPM (model dependent).

DIMENSIONS

Item	d1	L	L1	L2	L3	B	H	b ± 0.02	h ± 0.02	B1	H1	P	X	Y	Z	Allowable Axial Load (Kgf)	Allowable Static Load (Kgf)	Maximum Speed (RPM)
TBI-BSC-SU-EK8	8	23	7	26	4	52	32	26	17	25	26	38	6.6	11	12	103	126.3	28000
TBI-BSC-SU-EK10	10	24	6	29.5	6	70	43	35	25	36	24	52	9	-	-	195	239.0	16800
TBI-BSC-SU-EK12	12	24	6	29.5	6	70	43	35	25	36	24	52	9	-	-	217	275.1	15400
TBI-BSC-SU-EK15	15	25	6	36	5	80	49	40	30	41	25	60	11	-	-	240	315.7	13300
TBI-BSC-SU-EK20	20	42	10	50	10	95	58	47.5	30	56	25	75	11	-	-	587	762.2	9100

2-X drill through ϕY counter bore depth Z

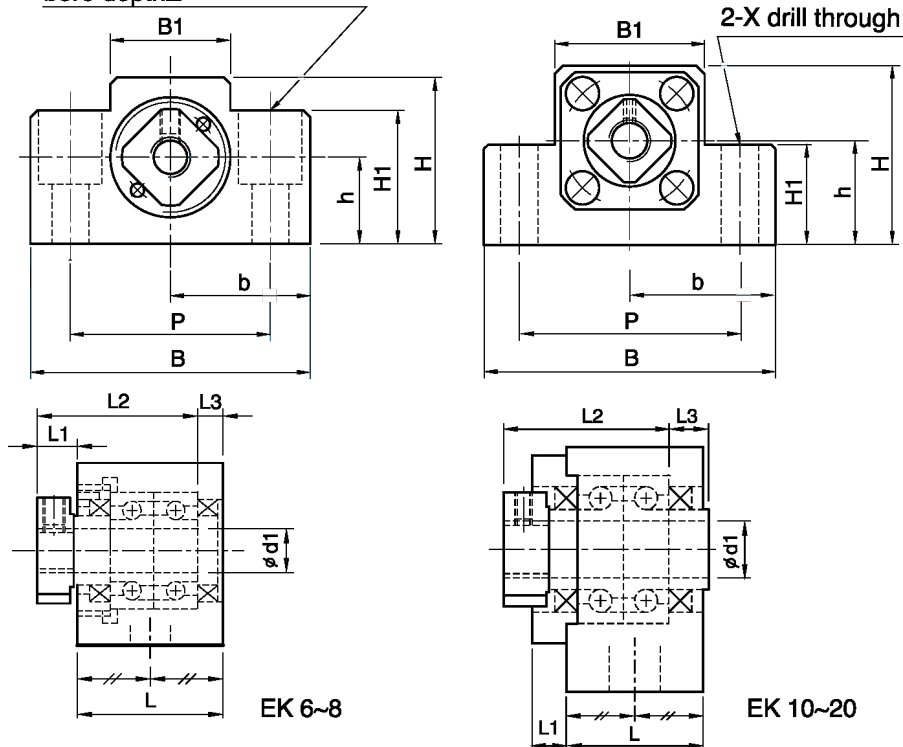

L011174

Item	Ball Screw Diameter	Input Shaft Diameter				Metric Screw Thread	
	d	A	B	E	F	M	S
TBI-BSC-SU-EK8	10, 12	8	6	35	9	M8X1	10
TBI-BSC-SU-EK10	12, 14, 15	10	8	36	15	M10X1	11
TBI-BSC-SU-EK12	14, 15, 16	12	10	36	15	M12X1	11
TBI-BSC-SU-EK15	18, 20	15	12	49	20	M12X1	13
TBI-BSC-SU-EK20	25, 28, 30	20	17	62	25	M15X1	17

