



Gearbox Application Sheet

Please return via fax or email: (714) 992-0471, applications@anaheimautomation.com

Name: _____ E-Mail: _____

Company: _____ Phone: _____

Address: _____ Fax: _____

City: _____ State: _____ Zip: _____

Current Quantity Requirements: _____

Estimated Annual Requirements: _____

Motor Specifications:

Units: mm in

Bolt Circle Diameter (D3): _____

Shaft Diameter (D1): _____

Pilot Diameter (D2): _____

Hole Diameter (D4): _____

Pilot Thickness (L5): _____

Shaft Length (L4): _____

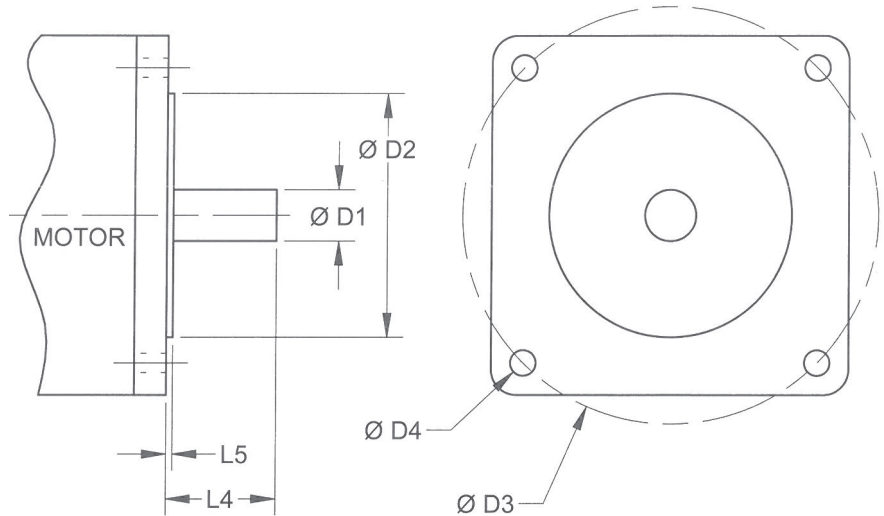

Gearbox Specifications:

Gearbox Part Number: _____

(Please provide an Anaheim Automation Gearbox Part Number if Available)

Please provide any additional information below:

