

# KNC-SRV-FD432 Series Servo Driver



## FEATURES

- **Input Voltage Range From 180-253VAC**
- **Rated Current is (RMS) 10A**
- **200-2300 Watt Power Range**
- **Position, Speed, and Torque Control**
- **RS232 and CAN BUS, or RS232 and RS485**
- **Fan Cooling**
- **MODBUS and CANopen Standard**
- **Requires 2500PPR Encoder Input**
- **Communication Software**
  - **Configure Parameters**
  - **I/O Signal Monitoring**
  - **Speed and Position Curves**
  - **Gain Adjustments**
- **Programmable Inputs and Outputs**
  - **7 Inputs**
  - **4 Outputs**
- **CE Certified**



## DESCRIPTION

The KNC-SRV-FD432 Series Servo Drive is a great fit for applications requiring position, speed and/or torque control methods. The uniqueness of this servo drive is the flexibility of using a single servo drive that can accommodate motors with power ratings ranging from 200-2300W. Also, it is designed to switch dynamically among different control methods for more flexible operation. The FD432 Series Servo Drive operates with 180-253VAC input. These drives come standard with an RS232 and RS485 which can be operated using MODBUS Protocol, a CAN BUS port to be operated using CANopen Protocol, or can be operated using our Free, Easy-to Use Software. Please consult our Application Engineers for more information.

## SPECIFICATIONS

Catagory	Servo Driver	Servo Motor	Description	Power/Brake Cable	Encoder Cable	Rated Speed/ Rated Torque/Rated Current
Medium Inertia 220V	KNC-SRV- FD432-LA-000	KNC-SRV-SMH110D-0105- 20AAK-4LKC	YL22 Standard Connector	KNC-SRV-MOT- 008-LL-KC1	KNC-SRV- ENCCA-LL-KC1	2000rpm/5Nm/ 5.9A
		KNC-SRV-SMH110D-0105- 20ABK-4LKC	YL24 Standard Connector w/Brake	KNC-SRV-MOT- 008-LL-KC2-B		
	KNC-SRV- FD432-CA-000	KNC-SRV-SMH110D-0125- 30AAK-4LKC	YL22 Standard Connector	KNC-SRV-MOT-008- LL-KC1	KNC-SRV- ENCCA-LL-KC1	3000rpm/4Nm/ 6.5A
		KNC-SRV-SMH110D-0125- 30ABK-4LKC	YL24 Standard Connector w/Brake	KNC-SRV-MOT- 008-LL-KC2-B		
	KNC-SRV- FD432-AA-000	SMH110D-0126-20AAK-4LKC	YL22 Standard Connector	KNC-SRV-MOT- 008-LL-KC1	KNC-SRV- ENCCA-LL-KC1	2000rpm/6Nm/ 6.2A
			YL24 Standard Connector w/Brake	KNC-SRV-MOT- 008-LL-KC2-B		

L011486

SPECIFICATIONS

Category	Servo Driver	Servo Motor	Description	Power/Brake Cable	Encoder Cable	Rated Speed/ Rated Torque/Rated Current
Medium Inertia 220V/ 380V	KNC-SRV-FD432-LA-000	KNC-SRV-SMH130D-0105-20AAK-4HKC	YL24 Standard Connector	KNC-SRV-MOT-008-LL-KC2	KNC-SRV-ENCCA-LL-KC1	2000rpm/ 5Nm/ 4.3A
		KNC-SRV-SMH130D-0105-20ABK-4HKC	YL24 Standard Connector w/Brake	KNC-SRV-MOT-008-LL-KC2-B		
	KNC-SRV-FD432-CA-000	KNC-SRV-SMH130D-0157-20AAK-4HKC	YL24 Standard Connector	KNC-SRV-MOT-008-LL-KC2		2000rpm/ 7.5Nm/ 6.3A
		KNC-SRV-SMH130D-0157-20ABK-4HKC	YL24 Standard Connector w/Brake	KNC-SRV-MOT-008-LL-KC2-B		

DIMENSIONS

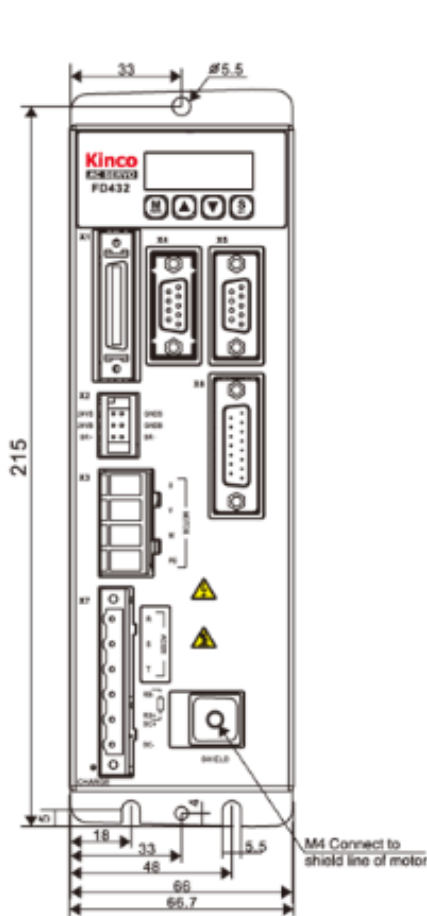

Note: All Dimensions in (mm)

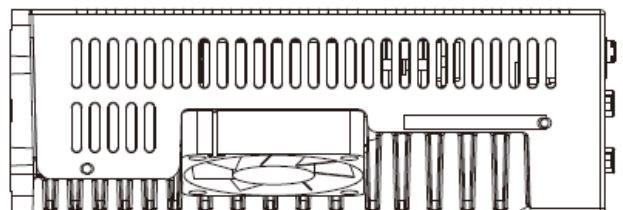
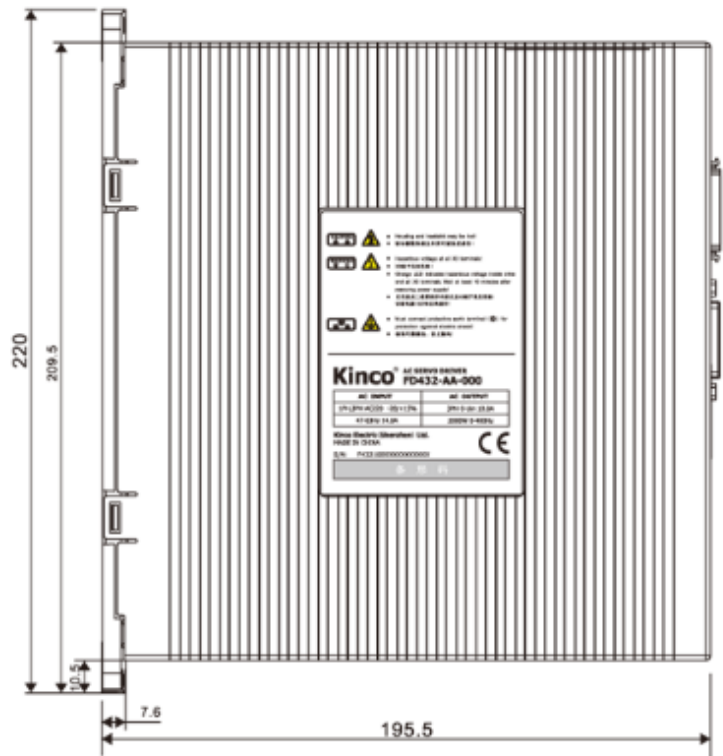

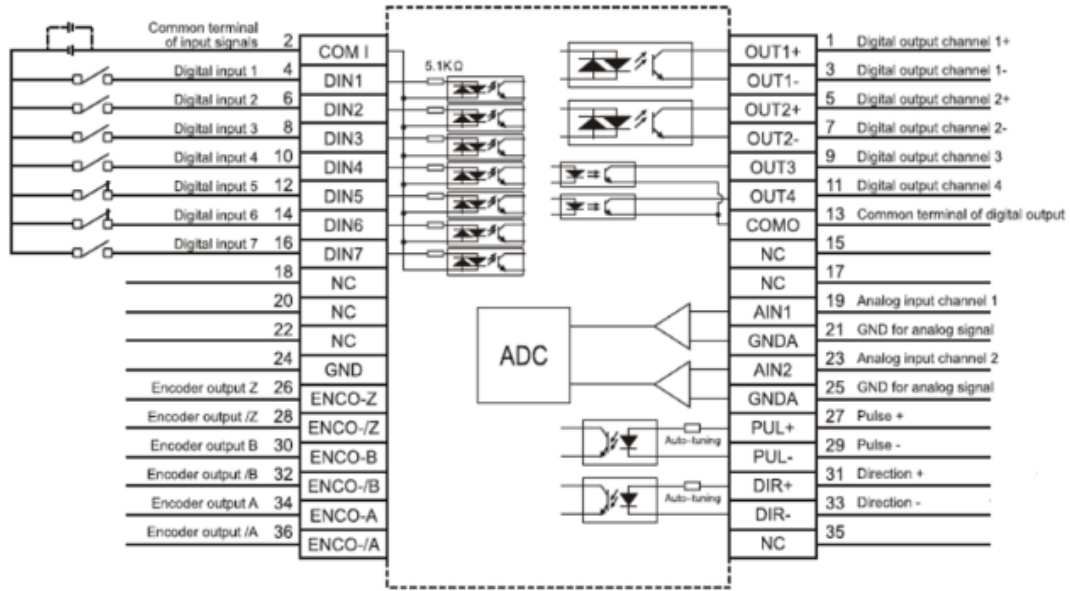

X1

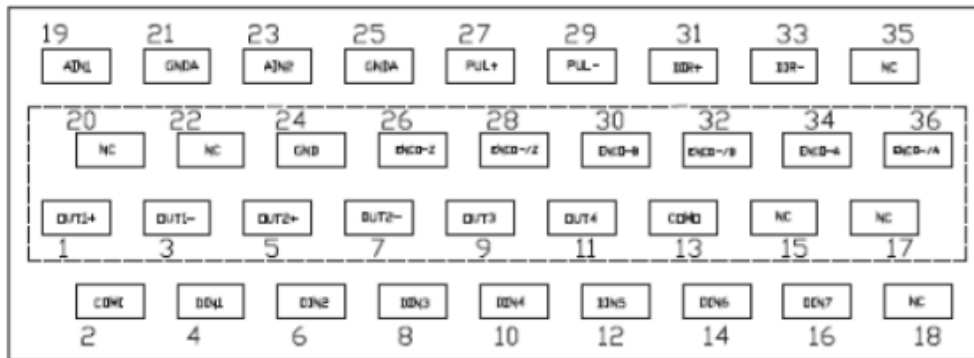

Pin #	Signal	Pin #	Signal	Pin #	Signal	Pin #	Signal
2	COM1	1	OUT1+	20	NC	19	AIN1
4	DIN1	3	OUT1-	22	NC	21	GNDA
6	DIN2	5	OUT2+	24	GND	23	AIN2
8	DIN3	7	OUT2-	26	ENCO-Z	25	GNDA
10	DIN4	9	OUT3	28	ENCO-/Z	27	PUL+
12	DIN5	11	OUT4	30	ENCO-B	29	PUL-
14	DIN6	13	COM0	32	ENCO-/B	31	DIR+
16	DIN7	15	NC	34	ENCO-A	33	DIR-
18	NC	17	NC	36	ENCO-/A	35	NC

**RS485**

PIN Number	Signal
1	NC
2	RX+
3	TX+
4	NC
5	GND
6	+5V
7	RX-
8	TX-
9	NC

**CAN**

PIN Number	Signal
1	NC
2	CAN_L
3	GND
4	NC
5	NC
6	NC
7	CAN_H
8	NC
9	NC

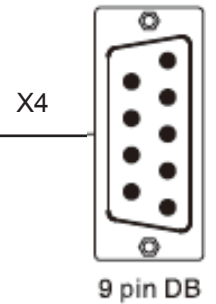
**RS232**

PIN Number	Signal
1	NC
2	TX
3	RX
4	NC
5	GND
6	NC
7	NC
8	NC
9	NC

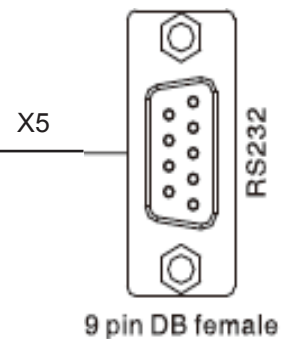

PIN No.	Signal	PIN No.	Signal
1	+5V	9	GND
2	A	10	/A
3	B	11	/B
4	Z	12	/Z
5	U	13	/U
6	V	14	/V
7	W	15	/W
8	PTC_IN		

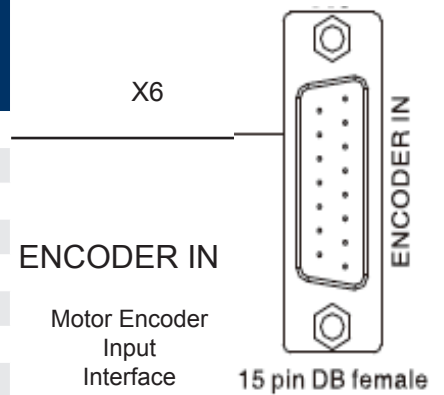

Operation Environment	Operating Temperature	0 ~ 40°C
	Storage Temperature	-10° C~70°C
	Humidity (Non-Condensing)	Below 90%RH
	Protection Class	IP20
	Installation Environment	Installed in a Dust-Free, Dry and Lockable Environment (Such as in a Electrical Cabinet)
	Installation Mode	Vertical Installation
	Altitude	No Power Limitation Below 1000m
	Atmospheric Pressure	86kpa-106kpa

Model Parameter		KNC-SRV-FD432 -■A-000
Power	Main Supply Voltage	Single-Phase or Three-Phase AC220V -20/+15% 47~63Hz
	Control Circuit Voltage	18VDC~30VDC 1A
Current	Rated Current (RMS)	10A
	Peak Current (PEAK)	27.5A
Feedback Signal		2500PPR (Incremental Encoder with 5V Supply)
Brake Chopper		Use an External Braking Resistor According to Application, Mainly in Occasion of Quick Stop
Brake Chopper Threshold		DC380V ± 5V
Over-Voltage Alarming Threshold		DC400V ± 5V
Under-Voltage Alarming Threshold		DC200V ± 5V
Cooling Method		Fan
Weight		2.4 Kg
Digital Input	Input Specification	7 Digital Inputs, with COM1 Terminal for PNP (High Level Valid 12.5-30V) or NPN (Low Level Valid) Connection.
	Input Function	Define Freely According to Requirement, Supporting Following Functions: Driver Enable, Driver Fault Reset, Driver Mode Control, Proportional Control, Positive Limit, Negative Limit, Homing Signal, Reverse Command, Internal Speed Section Control, Internal Positive Section Control, Quick Stop, Start Homing, Active Command, Switch Electronic Gear Ratio, Switch Gain.
Digital Output	Output Specification	5 Digital Outputs, OUT1-OUT4 Current is 100mA, BR+/BR- (Brake Control Output) Current is 500mA, Can Drive Brake Device Directly)
	Output Function	Define Freely According to Requirement, Supporting Following Functions: Driver Ready, Driver Fault, Position Reached, Motor at Zero Speed, Motor Brake, Motor Speed Reached, Z Signal, Maximum Speed Obtained in Torque Mode, Motor Brake, Position Limiting, Reference Found, Multi-Position Reached
	Analog Input	2 Analog Input Can Be Used to Control Speed and Torque, the Input Range is - 10V~10V
	Encoder Signal Output	Output the Encoder Signal of Motor, Used in Multiple Axis Synchronous Control, Supports 2MHz at Most
	RS232	The Max. Baudrate is 115.2KHz, Use JD-PC Software to communicate with PC, or Via Free Protocol to communicate with controller.
	Protection Functions	Over-Voltage Protection, Under-Voltage Protection, Motor Over-Heat Protection (I <sup>2</sup> T), Short-Circuit Protection, Drive Over-Heat Protection, Etc.
	RS485	The Max. 115.2KHz, use Modbus RTU protocol to communicate with controller
	CAN BUS	Supports 1MHz Baud Rate, Communicates with Controller via CANopen Protocol

**NOTE: ■ = L: Communication Port RS232, RS485**

**■ = AC: Communication Port RS232, CANopen**