

# KNC-SRV-FD432S Series Servo Driver



## FEATURES

- **Input Voltage Range From 176-253VAC**
- **Rated Current is (RMS) 11A**
- **1000-2000 Watt Power Range**
- **Position, Speed, and Torque Control**
- **RS232 & RS485 (LA) or RS232 & CAN BUS (AA/CA)**
- **Communication Protocol: MODBUS**
- **Supports Motors with High-Resolution Encoders**
- **Communication Software**
  - **Configure Parameters**
  - **I/O Signal Monitoring**
  - **Speed and Position Curves**
  - **Gain Adjustments**
- **Programmable Inputs and Outputs**
  - **7 Inputs / 4 Outputs**
- **2 Analog Inputs**
- **CAN BUS Port and CANopen Optional**
- **CE Certified**



## DESCRIPTION

The KNC-SRV-FD432S Series Servo Drives are a great fit for applications requiring position, speed and/or torque control methods. Available with 220VAC Single-Phase or Three-Phase Input. The 2S version Servo Driver supports motors with higher resolution encoders: 16-bit multi turn encoder, 17-bit single turn encoder, 20-bit single turn encoder, 17-bit mechanical encoder, and 2500 PPR Encoder. The uniqueness of this Servo Drive is the flexibility of using a single Servo Drive that can accommodate motors with power ratings ranging from 1000-2000W. Also, it is designed to switch dynamically among different control methods for more flexible operation. The KNC-SRV-FD432S Series Servo Drive operates with 176-253VAC input. The KNC-SRV-FD432S-LA-000 Servo Drive comes standard with RS232 and RS485 communication ports. The KNC-SRV-FD432S-AA-000 and KNC-SRV-FD432S-CA-000 Servo Drives come standard with RS232 and CAN BUS communication ports. These drives can be operated using MODBUS Protocol or the free, Easy-to-Use Software.

## SPECIFICATIONS

Servo Driver	Servo Motor	Description	Power/Brake Cable	Encoder Cable	Rated Speed/Rated Torque/Rated Current
KNC-SRV-FD432S-LA-000	KNC-SRV-SMH80S-0100-30AAK-3LKH	YL22 Standard Connector	KNC-SRV-MOT-008-05-KL	KNC-SRV-ENCCA-05-KH	3000rpm/3.18Nm/6.3A
	KNC-SRV-SMH80S-0100-30ABK-3LKH	YL24 Standard Connector w/Brake	KNC-SRV-BRA-05-KL		
KNC-SRV-FD432S-CA-000	KNC-SRV-SMH110D-0105-20AAK-4LKC	YL22 Standard Connector	KNC-SRV-MOT-008-05-KC1	KNC-SRV-ENCCA-05-KC1	2000rpm/5Nm/5.9A
	KNC-SRV-SMH110D-0105-20ABK-4LKC	YL24 Standard Connector w/Brake	KNC-SRV-MOT-008-05-KC2-B		
KNC-SRV-FD432S-AA-000	KNC-SRV-SMH110D-0125-30AAK-4LKC	YL22 Standard Connector	KNC-SRV-MOT-008-05-KC1	KNC-SRV-ENCCA-05-KC1	3000rpm/4Nm/6.5A
	KNC-SRV-SMH110D-0125-30ABK-4LKC	YL24 Standard Connector w/Brake	KNC-SRV-MOT-008-05-KC2-B		
	KNC-SRV-SMH110D-0126-20AAK-4LKC	YL22 Standard Connector	KNC-SRV-MOT-008-05-KC1		3000rpm/4Nm/6.2A
	KNC-SRV-SMH110D-0126-20ABK-4LKC	YL24 Standard Connector w/Brake	KNC-SRV-MOT-008-05-KC2-B		

L011627

SPECIFICATIONS

Servo Driver	Servo Motor	Description	Power/Brake Cable	Encoder Cable	Rated Speed/ Rated Torque/Rated Current
KNC-SRV-FD432S-LA-000	KNC-SRV-SMH130D-0105-20AAK-4HKC	YL24 Standard Connector	KNC-SRV-MOT-008-05-KC2	KNC-SRV-ENCCA-05-KC1	2000rpm/ 5Nm/ 4.3A
KNC-SRV-FD432S-CA-000	KNC-SRV-SMH130D-0105-20ABK-4HKC	YL24 Standard Connector w/Brake	KNC-SRV-MOT-008-05-KC2-B		
KNC-SRV-FD432S-AA-000	KNC-SRV-SMH130D-0157-20AAK-4HKC	YL24 Standard Connector	KNC-SRV-MOT-008-05-KC2		2000rpm/ 7.5Nm/ 6.3A
	KNC-SRV-SMH130D-0157-20ABK-4HKC	YL24 Standard Connector w/Brake	KNC-SRV-MOT-008-05-KC2-B		

DIMENSIONS

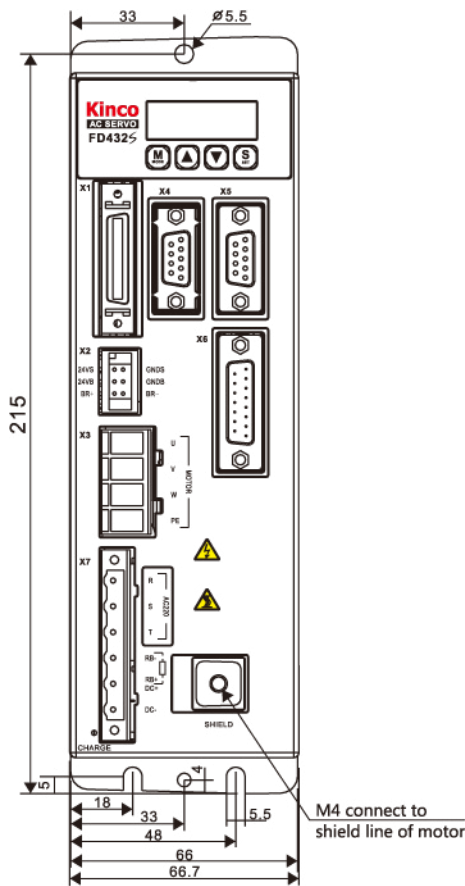

Note: All Dimensions in (mm)

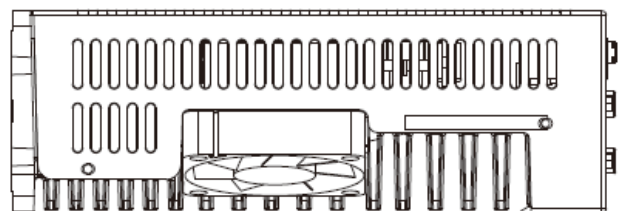
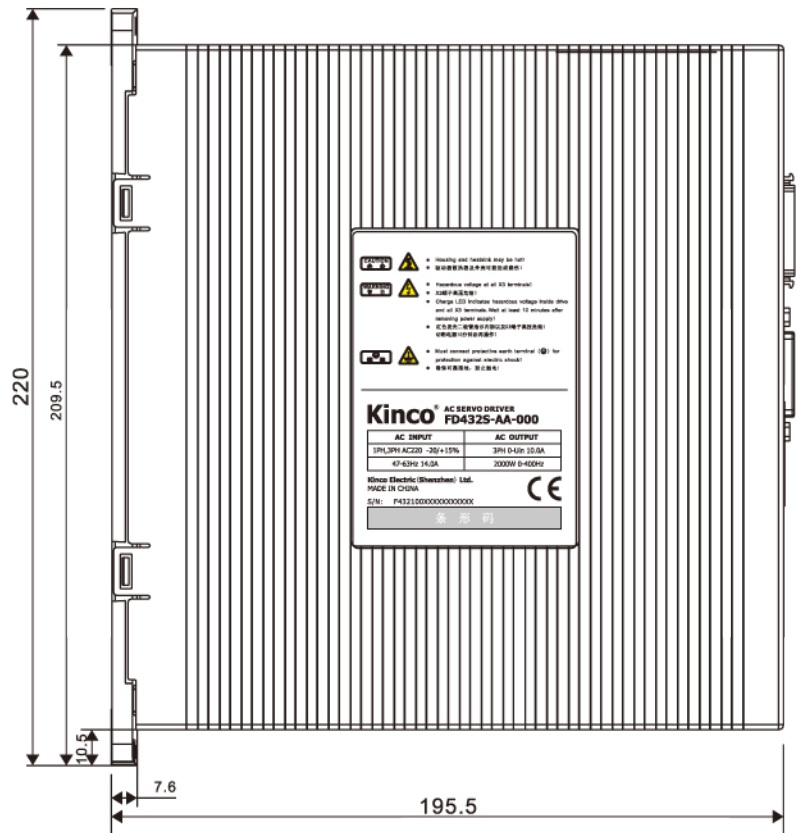

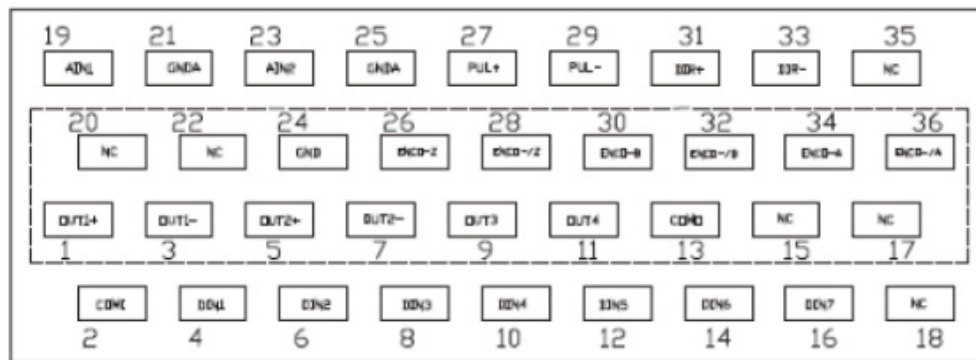
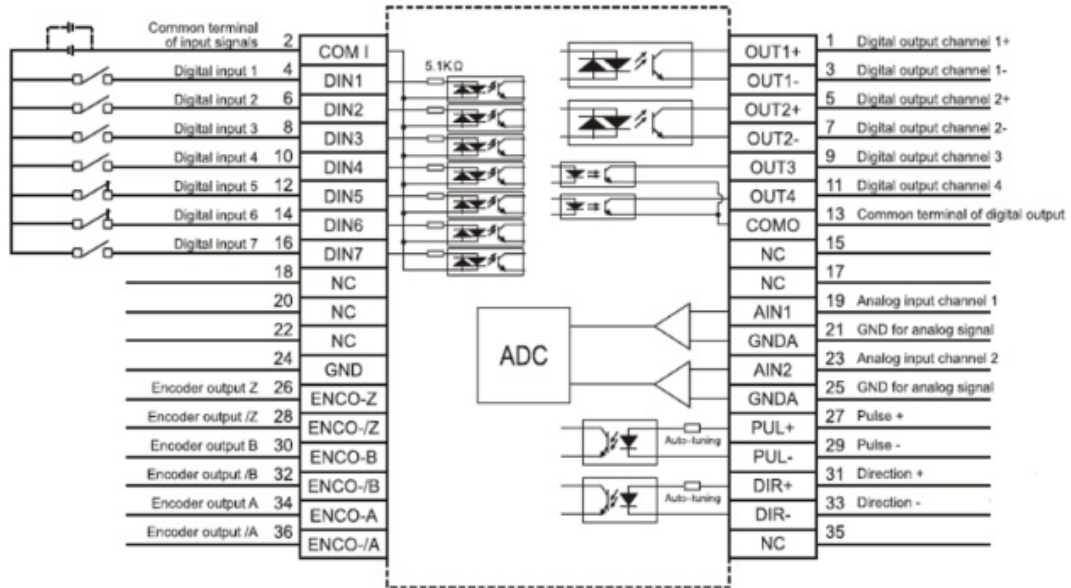

X1

Pin #	Signal	Pin #	Signal	Pin #	Signal	Pin #	Signal
2	COM1	1	OUT1+	20	NC	19	AIN1
4	DIN1	3	OUT1-	22	NC	21	GNDA
6	DIN2	5	OUT2+	24	GND	23	AIN2
8	DIN3	7	OUT2-	26	ENCO-Z	25	GNDA
10	DIN4	9	OUT3	28	ENCO-/Z	27	PUL+
12	DIN5	11	OUT4	30	ENCO-B	29	PUL-
14	DIN6	13	COM0	32	ENCO-/B	31	DIR+
16	DIN7	15	NC	34	ENCO-A	33	DIR-
18	NC	17	NC	36	ENCO-/A	35	NC



**RS485**

PIN Number	Signal
1	NC
2	RX+
3	TX+
4	NC
5	GND
6	+5V
7	RX-
8	TX-
9	NC

**CAN**

PIN Number	Signal
1	NC
2	CAN_L
3	GND
4	NC
5	NC
6	NC
7	CAN_H
8	NC
9	NC

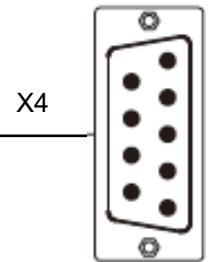

**9 Pin DB**
**RS232**

PIN Number	Signal
1	NC
2	TX
3	RX
4	NC
5	GND
6	NC
7	NC
8	NC
9	NC

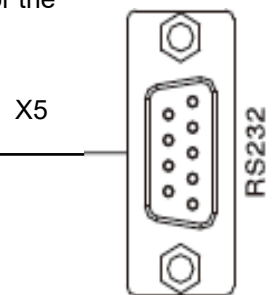
\*Note: The CAN option is available only for the AA and the CA versions

**9 Pin DB Female**

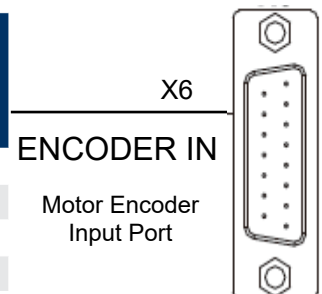
PIN No.	Incremental Encoder Signal	PIN No.	Incremental Encoder Signal	PIN No.	Communication Encoder Signal	PIN No.	Communication Encoder Signal
1	+5V	9	GND	1	+5V	9	GND
2	A	10	/A	2	NC	10	NC
3	B	11	/B	3	NC	11	NC
4	Z	12	/Z	4	NC	12	NC
5	U	13	/U	5	NC	13	NC
6	V	14	/V	6	NC	14	NC
7	W	15	/W	7	SD	15	/SD
8	PTC_IN			8	NC		

**ENCODER IN**  
 Motor Encoder Input Port

**15 Pin DB Female**

Model Parameter		KNC-SRV-FD432S Series
Operation Environment	Operating Temperature	0°C ~ 40°C (ice free)
	Storage Temperature	-10°C ~ 70°C (ice free)
	Humidity (Non-Condensing)	5 ~ 90% RH
	Protection Class	IP20
	Installation Environment	Installed in a Dust-Free, Dry and Lockable Environment (Such as in a Electrical Cabinet)
	Installation Mode	Vertical Installation
	Altitude	No Power Limitation Below 1000m
	Atmospheric Pressure	86kpa-106kpa

Model Parameter		KNC-SRV-FD432S Series
Power	Main Supply Voltage	Single-Phase or Three-Phase AC220V -20/+15% 47~63Hz
	Control Circuit Voltage	18VDC ~ 30VDC 1A
Current	Rated Current (RMS)	11A
	Peak Current (PEAK)	27.5A
Feedback Signal		2500PPR (Incremental Encoder with 5V Supply), 16 Bit Multi-Turn Absolute Encoder, 20 Bit Single-Turn Absolute Encoder.
Brake Chopper		Use an External Braking Resistor According to Application, Mainly in Occasion of Quick Stop.
Brake Chopper Threshold		DC380V ± 5V
Over-Voltage Alarming Threshold		DC400V ± 5V
Under-Voltage Alarming Threshold		DC200V ± 5V
Cooling Method		Fan
Weight		2.4 Kg
Digital Input	Input Specification	7 Digital Inputs, with COM1 Terminal for PNP (High Level Valid 12.5-30V) or NPN (Low Level Valid) connection.
	Input Function	Define Freely According to Requirement, Supporting Following Functions: Driver Enable, Driver Fault Reset, Driver Mode Control, Proportional Control, Positive Limit, Negative Limit, Homing Signal, Reverse Command, Internal Speed Section Control, Internal Positive Section Control, Quick Stop, Start Homing, Active Command, Switch Electronic Gear Ratio, Switch Gain.
Digital Output	Output Specification	5 Digital Outputs, OUT1-OUT4 Current is 100mA, BR+/BR- (Brake Control Output) Current is 500mA, Can Drive Brake Device Directly)
	Output Function	Define Freely According to Requirement, Supporting Following Functions: Driver Ready, Driver Fault, Positon Reached, Motor at Zero Speed, Motor Brake, Motor Speed Reached, N Signal, Maximum Speed Obtained in Torque Mode, Motor Brake, Position Limiting, Reference Found, Multi-Position Reached
	Analog Input	2 Analog Input, can be used to control Speed and Torque, the Input Range is -10V ~ 10V
	Encoder Signal Output Function	Output Encoder Signal is Optional, Used in Multiple Axis Synchronous Control, Supports 2MHz at Most
	RS232	The Max. Baudrate is 115.2KHz, Use JD-PC Software to Communicate with PC, or via free protocol to communicate with the Controller, Connections with PC (2-2, 3-3, 5-5) or Controller
	Protection Functions	Over-Voltage Protection, Under-Voltage Protection, Motor Over-Heat Protection (I <sup>2</sup> T), Short-Circuit Protection, Drive Over-Heat Protection, Etc.
RS485		The Max. Baudrate is 115.2KHz, use Modbus RTU protocol to communicate with the controller.
CAN BUS		Supports 1M Baud Rate, Communicates with Controller via CANopen Protocol