

KNC-SRV-SMC80S-0075 Servo Motor



FEATURES

- 24-70VDC or 220VAC
- 750W Power Rating
- Rated Torque of 338 oz-in
- Maximum Speed of 3690 RPM
- 16 Bit Single-Turn Magnetic Encoder or 2500 PPR Incremental Encoder
- IP65 for Body, IP54 Shaft Seal
- Insulation Class F
- Brake Option Available



DESCRIPTION

The SMC80S-0075 Series Servo Motor offers a low-cost solution for motion control applications requiring position and speed control. With the 16 Bit Single-Turn Magnetic Encoder or 2500 PPR Incremental Encoder, it allows for better cushioning ability and higher cost-performance ratio. These Servo Motors have Insulation Class F which is the best Insulation Class on the market. They are very quiet with high reliability and stability in high temperature environments. These Servo Motors boast peak torque values up to 1,014 oz-in, provide excellent dynamic response, allow for 3 times the overload capacity, and has a rated torque of 338 oz-in. It is available in a 80mm square flange size, with a brake option.

ORDERING INFORMATION

SMC80S - 0075 - 30MAK - 3DSU

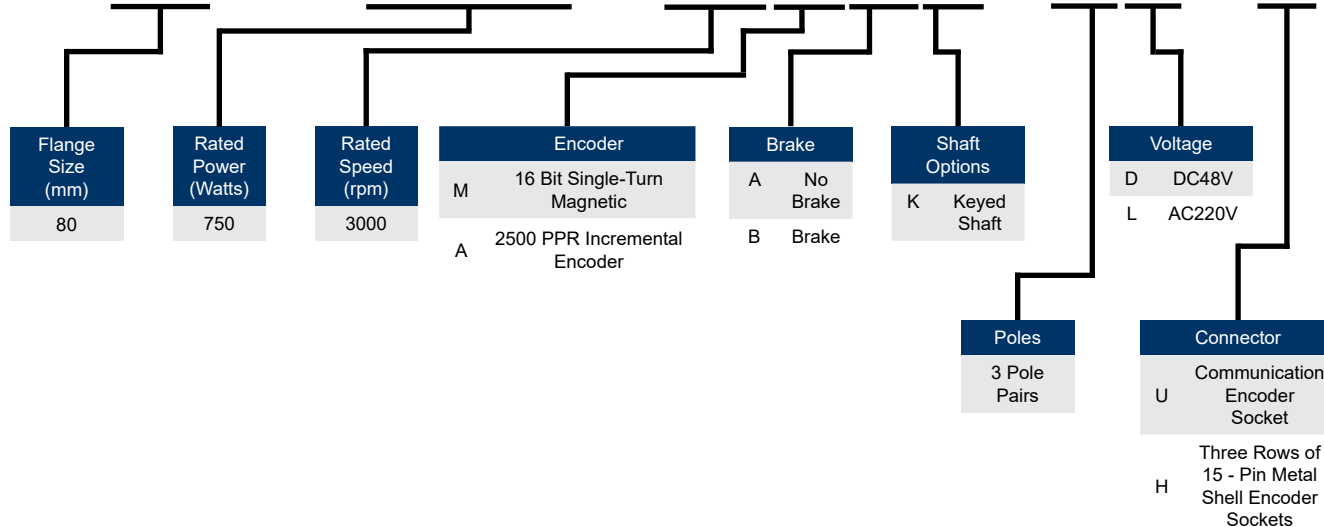

L011812

Model	KNC-SRV-SMC80S-0075-30MAK-3DSU KNC-SRV-SMC80S-0075-30MBK-3DSU
Compatible Driver	KNC-SRV-FD134S-LB-000
DC Link Voltage (VDC)	48
Rated Power (W)	750
Rated Torque (oz-in)	338
Rated Speed (RPM)	3000
Max Speed (RPM)	3690
Rated Current (A)	19
Maximum Torque (oz-in)	1014
Maximum Current (A)	57
Rated Standstill Torque (oz-in)	372
Rated Standstill Current (A)	20.9
Resistance Line-Line (Ω)	0.11
Inductance Line-Line (mH)	0.41
Electrical Time Constant (ms)	3.73
Mechanical Time Constant (ms)	1.183 1.198 (with brake)
Torque Constant Kt (oz-in/A)	18.7
Rotor Moment of Inertia Jm (oz-in-s ²)	0.01539 0.01556 (with brake)
Brake Holding Torque (oz-in)	453.1
Pole Pair Number	3
Maximum Voltage Rising du/dt (KV/ μ s)	8
Insulation Class	F
Maximum Radial Force F (N)	335
Maximum Axial Force F (N)	167.5
Weight (lbs)	6.17 7.50 (with brake)
Length of Motor (mm)	128.5 \pm 1.5 158 \pm 1.5 (with brake)

Model	KNC-SRV-SMC80S-0075-30AAK-3LKH KNC-SRV-SMC80S-0075-30ABK-3LKH
Compatible Driver	KNC-SRV-FD422S-CA-000 KNC-SRV-FD422S-AA-000 KNC-SRV-FD422S-LA-000
DC Link Voltage (VDC)	300
Rated Power (W)	750
Rated Torque (oz-in)	338
Rated Speed (RPM)	3000
Max Speed (RPM)	5500
Rated Current (A)	3.8
Maximum Torque (oz-in)	1015
Maximum Current (A)	11.4
Rated Standstill Torque (oz-in)	372
Rated Standstill Current (A)	4.2
Resistance Line-Line (Ω)	2.1
Inductance Line-Line (mH)	10.5
Electrical Time Constant (ms)	5
Mechanical Time Constant (ms)	0.9
Torque Constant Kt (oz-in/A)	93
Rotor Moment of Inertia Jm (oz-in-s ²)	0.01539 0.01556 (with brake)
Brake Holding Torque (oz-in)	453.1
Pole Pair Number	3
Maximum Voltage Rising du/dt (KV/ μ s)	8
Insulation Class	F
Maximum Radial Force F (N)	335
Maximum Axial Force F (N)	167.5
Weight (lbs)	6.17 7.49 (with brake)

KNC-SRV-SMC80S-0075-30MAK-3DSU

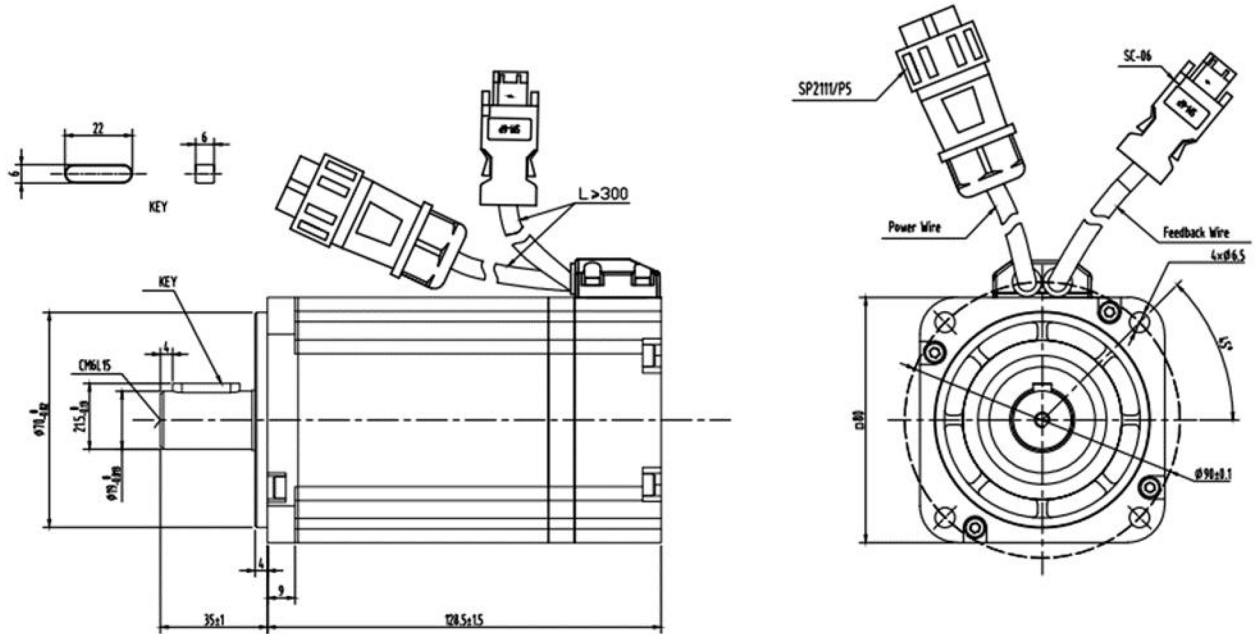

Dimensions are in mm

KNC-SRV-SMC80S-0075-30MBK-3DSU

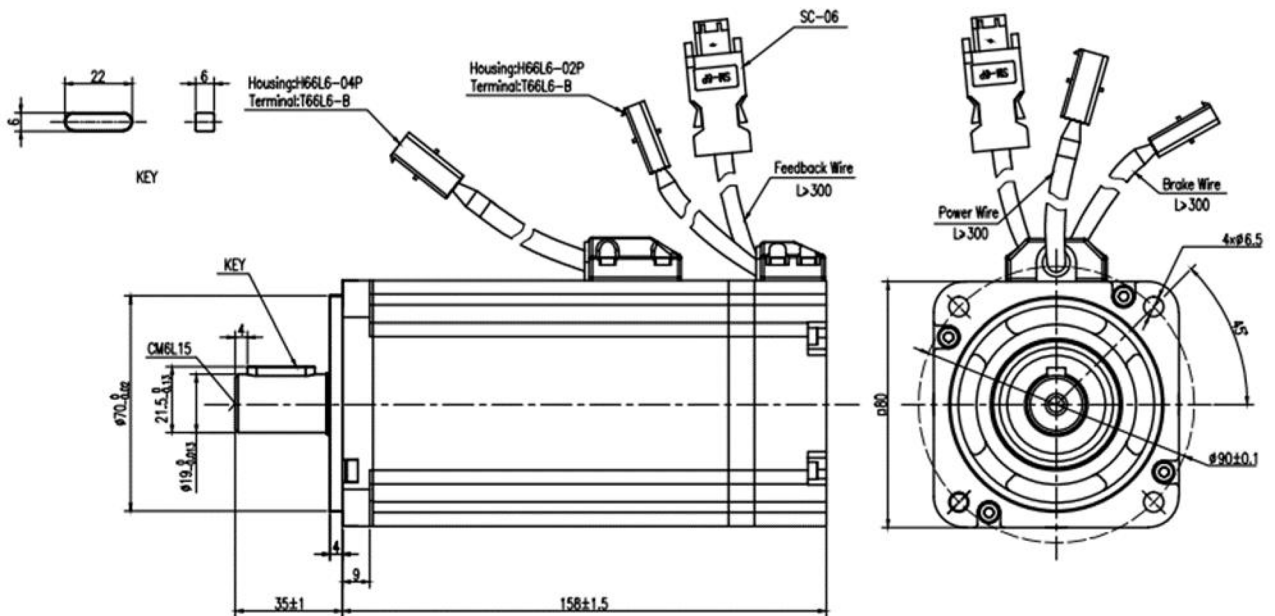

DIMENSIONS

KNC-SRV-SMC80S-0075-30AAK-3LKH

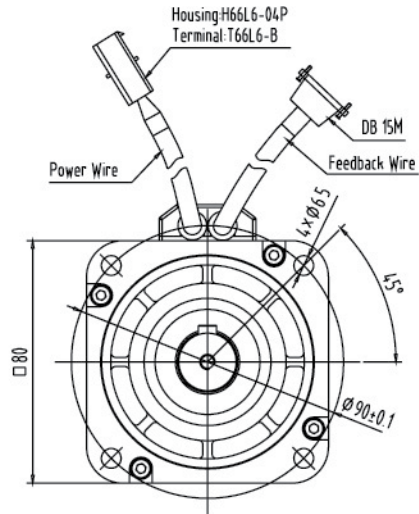
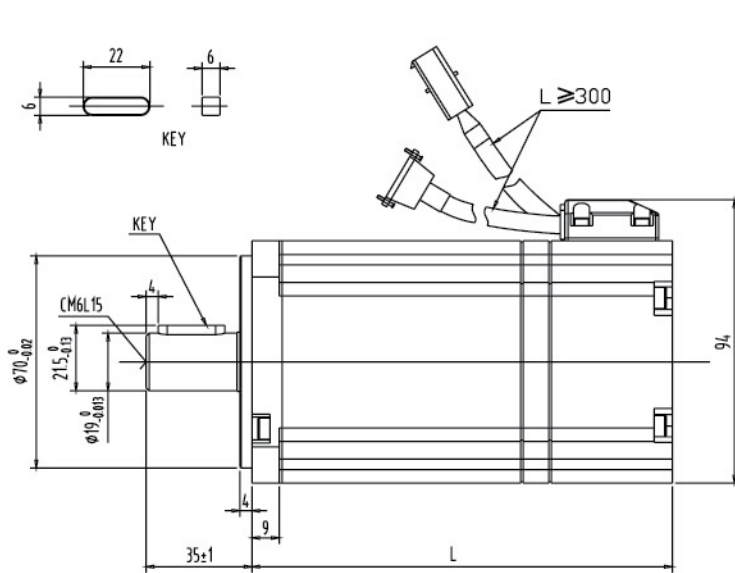

Model	KNC-SRV-SMC80S-0075-30AAK-3LKH KNC-SRV-SMC80S-0075-30ABK-3LKH
Length of Motor L (mm)	139 ± 1.5 182 ± 1.5 (with brake)

Dimensions are in mm

DIMENSIONS

KNC-SRV-SMC80S-0075-30ABK-3LKH

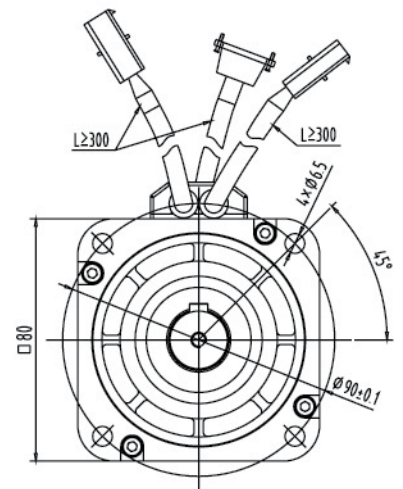
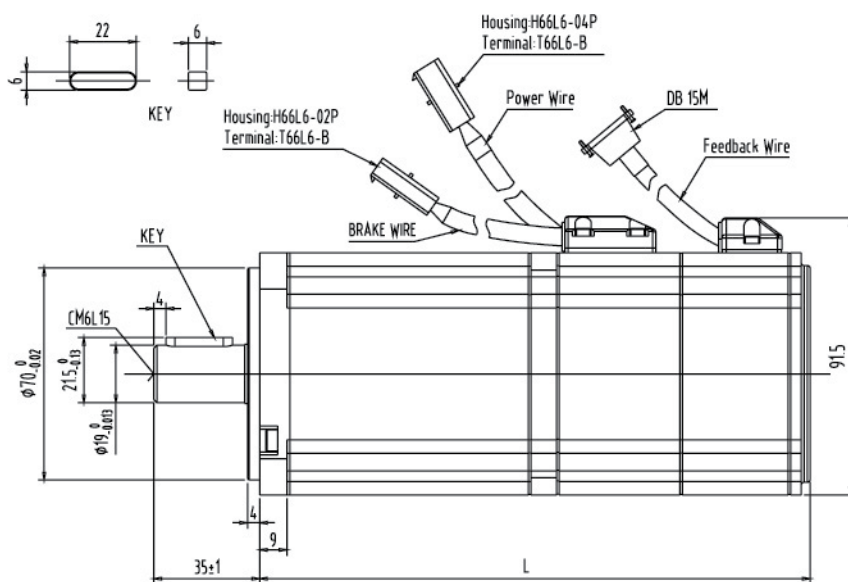

KNC-SRV-SMC80S-0075-30MAK-3DSU & KNC-SRV-SMC80S-0075-30MBK-3DSU

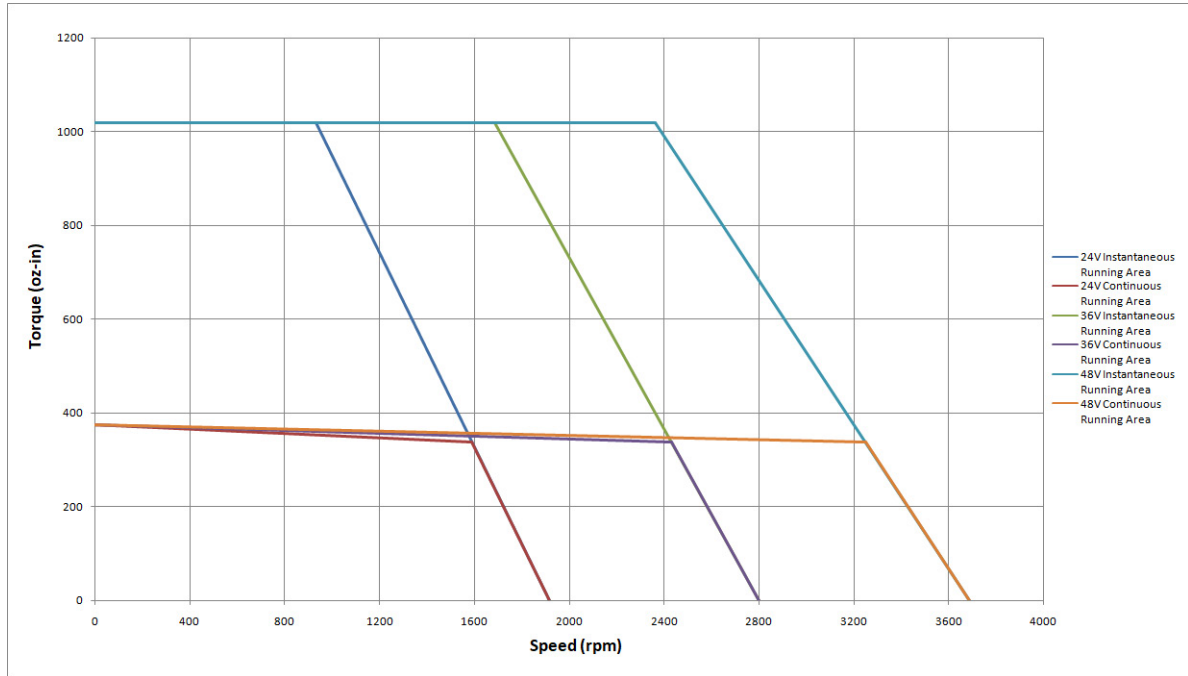

KNC-SRV-SMC80S-0075-30AAK-3LKH & KNC-SRV-SMC80S-0075-30ABK-3LKH

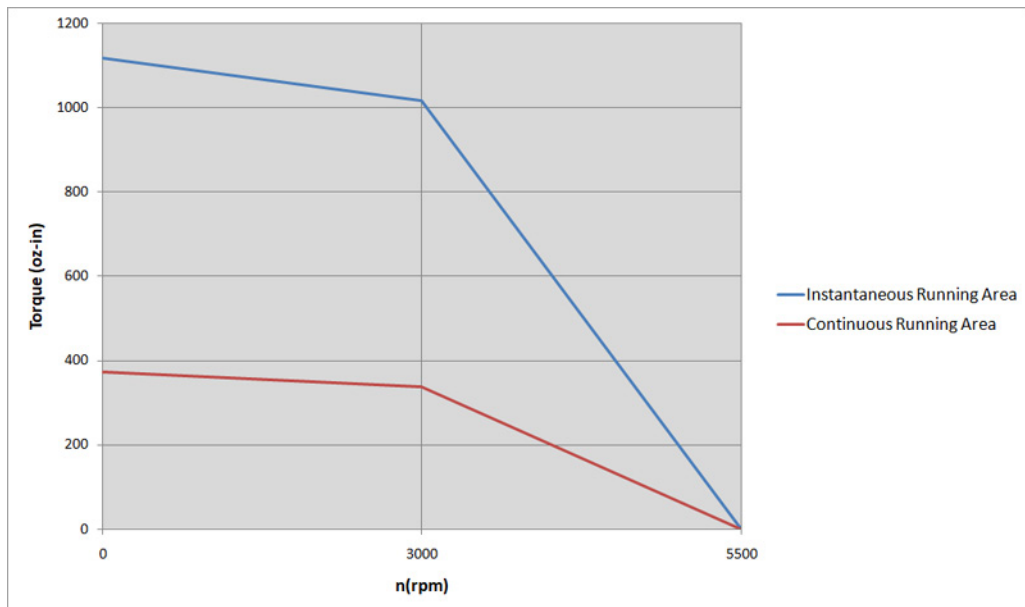

Motor Cable: KNC-SRV-MOT-015-05-KL-SP for KNC-SRV-SMC80S-0075-30MAK-3DSU & KNC-SRV-SMC80S-0075-30MBK-3DSU

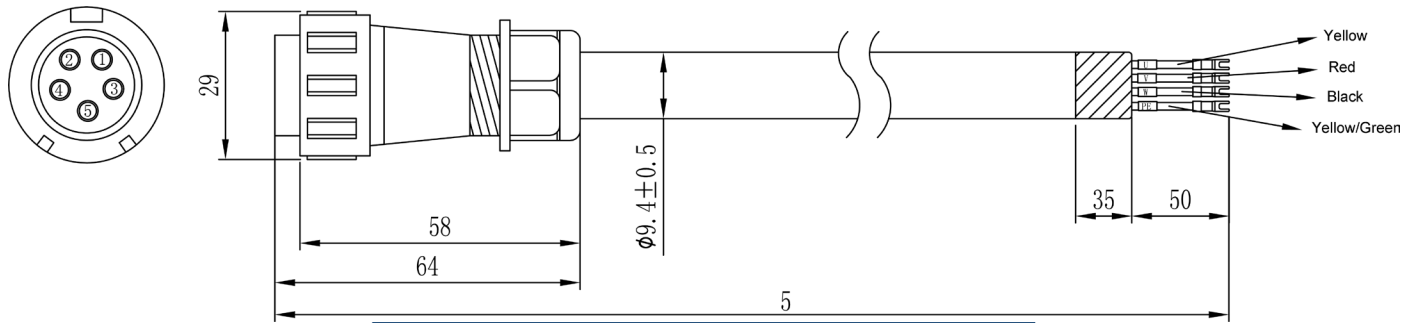

KNC-SRV-MOT-015-05-KL-SP		
Cable Color	Signal	Connector
Yellow	U	PIN 1
Red	V	PIN 2
Black	W	PIN 3
Yellow-green	PE + Shield	PIN 4

Motor Cable: KNC-SRV-MOT-005-05-KL for KNC-SRV-SMC80S-0075-30AAK-3LKH & KNC-SRV-SMC80S-0075-30ABK-3LKH

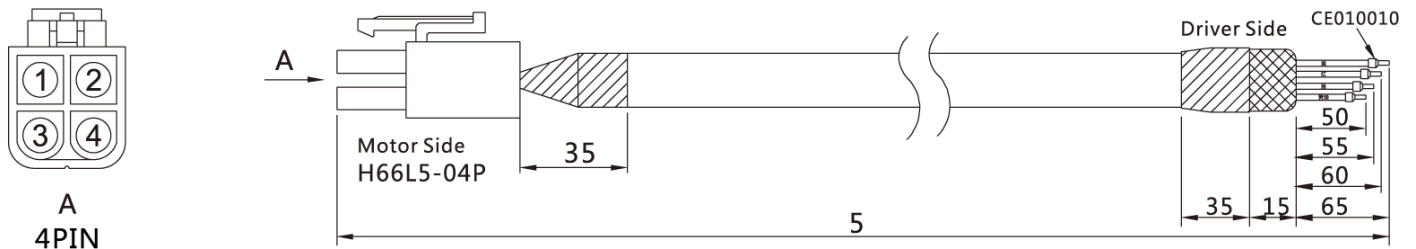

KNC-SRV-MOT-005-05-KL		
Cable Color	Signal	PIN #
Yellow	U	PIN 1
Red	V	PIN 2
Black	W	PIN 3
Yellow-green	PE	PIN 4

Brake Cable: KNC-SRV-BRA-05-KL for KNC-SRV-SMC80S-0075-30MBK-3DSU & KNC-SRV-SMC80S-30ABK-3LKH

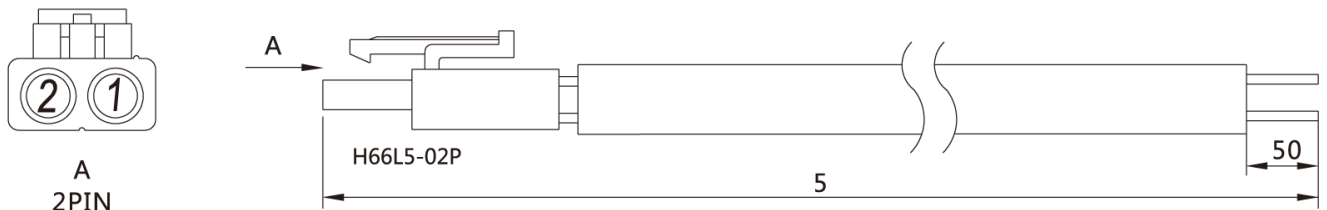

KNC-SRV-BRA-05-KL		
Cable Color	Signal	PIN #
Red	Brake +	PIN 1
Blue	Brake -	PIN 2

Encoder Cable: KNC-SRV-ENCHG-05-GU for KNC-SRV-SMC80S-0075-30MAK-3DSU & KNC-SRV-SMC80S-0075-30MBK-3DSU

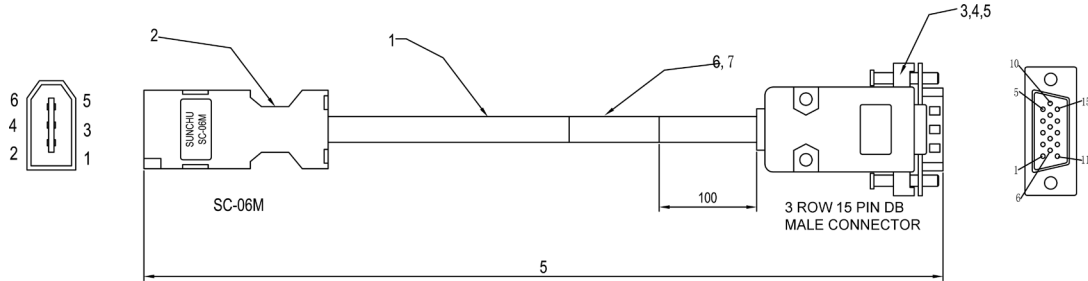

KNC-SRV-ENCHG-05-GU				
Wiring Cable	Color	Signal 1	Signal 2	DB15
PIN 1	Red	VDD	VDD	PIN1
PIN 2	Black	GND	GND	PIN2
PIN 3	Brown	MA_P+	\	PIN10
PIN 4	Blue	MA_N-	\	PIN15
PIN 5	Yellow	SLO_P+	SD	PIN9
PIN 6	Green	SLO_N-	/SD	PIN14
SHELL	SHIELD	SHIELD	SHIELD	SHELL

Encoder Cable: KNC-SRV-ENCCA-05-KH for KNC-SRV-SMC80S-0075-30AAK-3LKH & KNC-SRV-SMC80S-0075-30ABK-3LKH

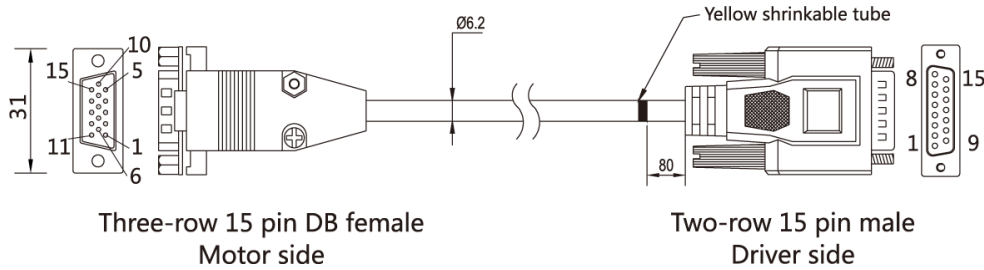

KNC-SRV-ENCCA-05-KH				
Three-Row Motor Side 15 PIN DB	Two-Row Driver Side 15 PIN DB	Signal	External Wire Color	Motor Wire Color
PIN 1	PIN 1	+5V	Red (thick)	Red
PIN 8	PIN 2	A	Brown	Blue-Black
PIN 7	PIN 3	B	Yellow	Green
PIN 6	PIN 4	Z	Green	Yellow
PIN 2	PIN 9	GND	Black (thick)	Black
PIN 13	PIN 10	/A	Brown-white	Blue
PIN 12	PIN 11	/B	Yellow-white	Green-black
PIN 11	PIN 12	/Z	Green-white	Yellow-black
Other PINs empty	Other PINs empty	n/a	n/a	n/a
Shell	Shell	Shield	Shield	Shield

Model	Motor Cable	Encoder Cable	Brake Cable
KNC-SRV-SMC80S-0075-30MAK-3DSU	KNC-SRV-MOT-015-05-KL-SP	KNC-SRV-ENCHG-05-GU	-
KNC-SRV-SMC80S-0075-30MBK-3DSU			KNC-SRV-BRA-05-KL

Model	Motor Cable	Encoder Cable	Brake Cable
KNC-SRV-SMC80S-0075-30AAK-3LKH	KNC-SRV-MOT-005-05-KL	KNC-SRV-ENCCA-05-KH	-
KNC-SRV-SMC80S-0075-30ABK-3LKH			KNC-SRV-BRA-05-KL

Model	KNC-SRV-SMC80S-0075-30MAK-3DSU KNC-SRV-SMC80S-0075-30MBK-3DSU
-------	--

Length of Motor	L(mm)	128.5 ± 1.5 158 ± 1.5 (with brake)
Cooling Method		Totally Enclosed, Non-Ventilated
Protection Level		IP65 for Body, Shaft Sealing IP54
Environmental Conditions of Operation	Temperature	-20°C~40°C (Non-freezing)
	Humidity	Below 90% RH (Non-condensing)
	Ambient Environment	Away from active gas, combustible gas, oil drops and dust
	Altitude	Maximum Altitude 4000m, Rated Power at 1000m or Below, Above 1000m: Decreasing 1.5% per 100m Rise

Model	KNC-SRV-SMC80S-0075-30AAK-3LKH KNC-SRV-SMC80S-0075-30ABK-3LKH
-------	--

Length of Motor	L(mm)	139 ± 1.5 182 ± 1.5 (with brake)
Cooling Method		Totally Enclosed, Non-Ventilated
Protection Level		IP65 for Body, Shaft Sealing IP54
Environmental Conditions of Operation	Temperature	-20°C~40°C (Non-freezing)
	Humidity	Below 90% RH (Non-condensing)
	Ambient Environment	Away from active gas, combustible gas, oil drops and dust
	Altitude	Maximum Altitude 4000m, Rated Power at 1000m or Below, Above 1000m: Decreasing 1.5% per 100m Rise