

# KNC-PKS-FD144S-13 - Servo System

FEATURES

- **24-70VDC**
- **Rated Torque of 566 oz-in**
- **Power Ratings up to 1260 Watts**
- **Maximum Speed of 4000 RPM**
- **2500 PPR Incremental Encoder**
- **IP65 for Body, IP54 Shaft Seal**
- **Brake Option Available**
- **Position, Speed, and Torque Control**
- **RS232 and RS485 Port**



DESCRIPTION

The KNC-PKS-FD144S-13 Servo System includes a 1260 Watt KNC-SRV-SMH110D-0120-30AAK-4DKR Servo Motor or KNC-SRV-SMH110D-0120-30ABK-4DKR Servo Motor with brake, operated by the KNC-SRV-FD144S-LB-000 Servo Drive. These packages are ideal and provide easy start-ups, convenience, and performance. The Servo Motors included in these packages provide torque up to 1699 oz-in. The KNC-SRV-FD144S-LB-000 Servo Drive is designed to switch dynamically among different control methods for more flexible operation and can operate position control mode either with pulse and direction inputs, 8 internal position points, or 8 internal speed points. Each system includes a 5m Motor Power Cable, 5m Encoder Cable and a Communication cable. If purchasing the option with a Brake then a 5m Brake Cable will be included as well.

Item	Rated Voltage (VDC)	Rated Speed (RPM)	Rated Torque (oz-in)	Rated Current (Arms)	Inertia (oz-in-sec <sup>2</sup> )	Torque Constant KT (oz-in/A)	Resistance (ohms)	Inductance (mH)	Brake (24VDC)	Motor Length (mm)	Shaft Diameter (mm)
KNC-PKS-FD144S-13-H11D-AAK-DKR	24-70	3000	566	32	0.08213	18.7	0.04	0.2	No	168	19
KNC-PKS-FD144S-13-H11D-ABK-DKR	24-70	3000	566	32	0.08638	18.7	0.04	0.2	Yes	228	19

ORDERING INFORMATION

## KNC-PKS-FD144S-13-H11D-AAK-DKR

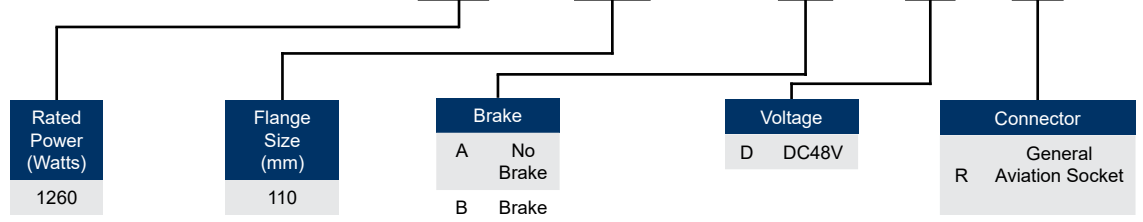

L011832

# KNC-SRV-SMH110D-0120 Motor Specifications



## FEATURES

- 24-70VDC
- 1260W Power Rating
- Rated Torque of 566 oz-in
- Maximum Speed of 4000 RPM
- Rated Speed of 3000 RPM
- 2500 PPR Incremental Encoder
- IP65 for Body, IP54 Shaft Seal
- Insulation Class F
- Brake Option Available
- CE Certified



## SPECS

Item	Rated Torque (oz-in)	Rated Power (Watts)	Rated Speed (rpm)	Rated Current (Arms)	Inertia (oz-in-sec <sup>2</sup> )	Torque Constant KT (oz-in/A)	Resistance (ohms)	Inductance (mH)	Length (mm)	Weight (lbs)
KNC-SRV-SMH110D-0120-30AAK-4DKR	566	1260	3000	32	0.08213	18.7	0.04	0.2	168	13.67
KNC-SRV-SMH110D-0120-30ABK-4DKR	566	1260	3000	32	0.08638	18.7	0.04	0.2	228	15.87

## DIMENSIONS

KNC-SRV-SMH110D-0120-30AAK-4DKR

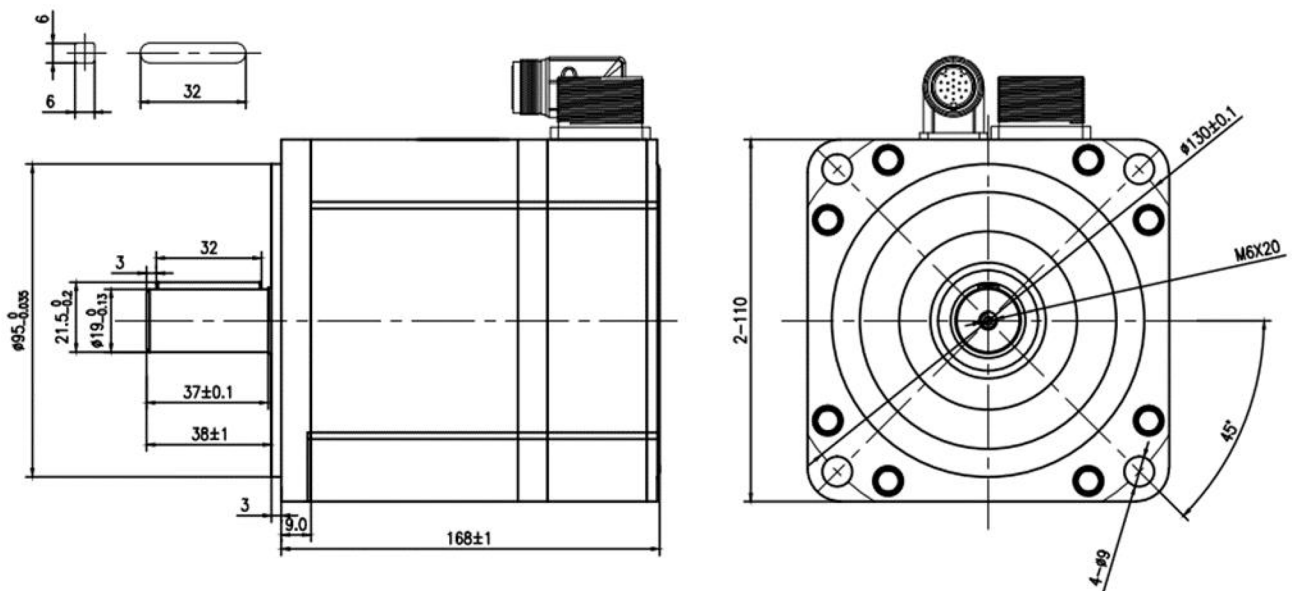

Dimensions are in mm

# KNC-SRV-SMH110D-0120 Motor Specifications



## DIMENSIONS

KNC-SRV-SMH110D-0120-30ABK-4DKR

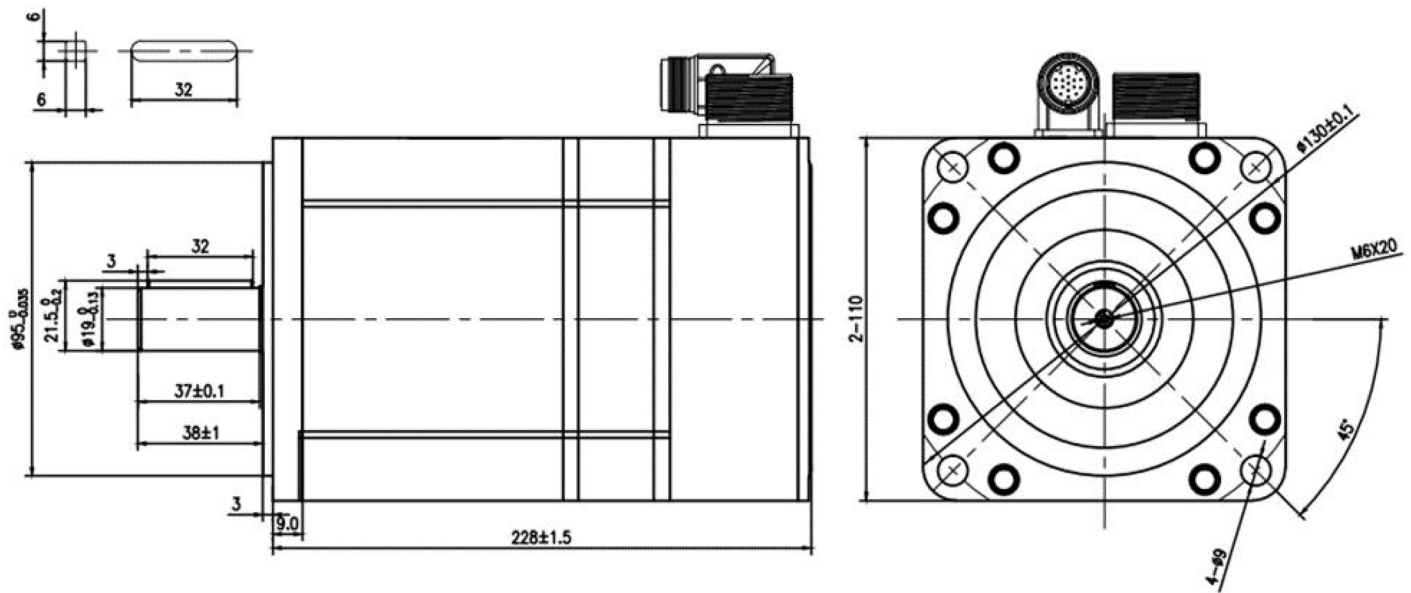

Dimensions are in mm

# KNC-SRV-SMH110D-0120

## Motor Specifications



### TORQUE CURVE

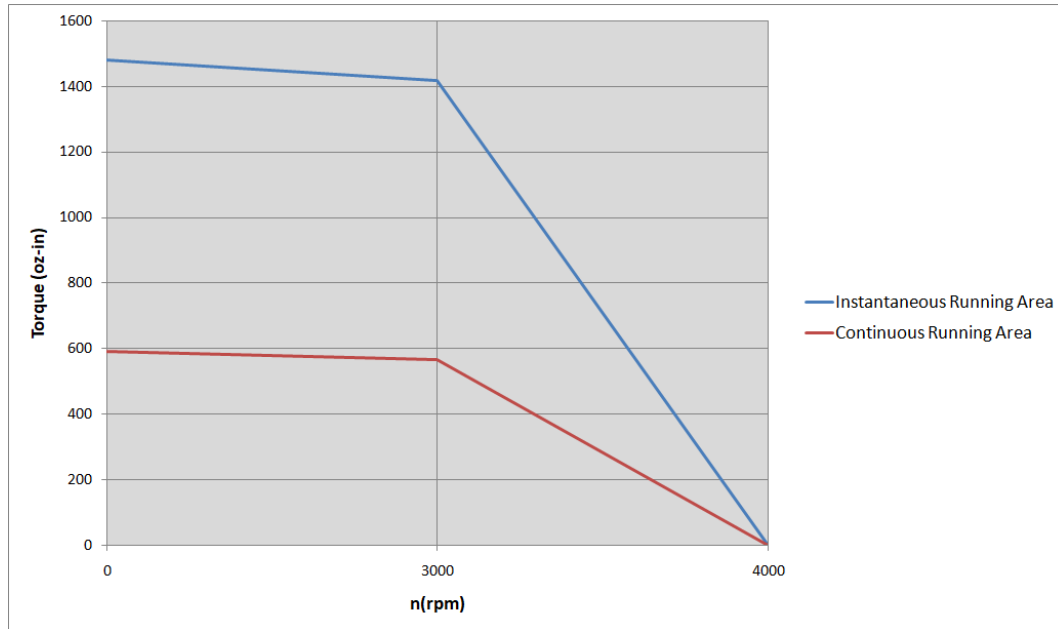

### WIRING PINOUTS

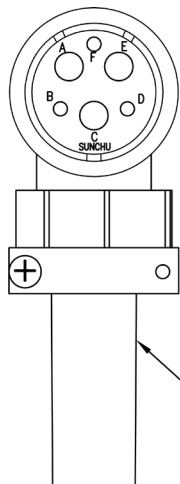

Motor Cable: KNC-SRV-MOT-040-05-KC5 for KNC-SRV-SMH110D-0120-30AAK-4DKR

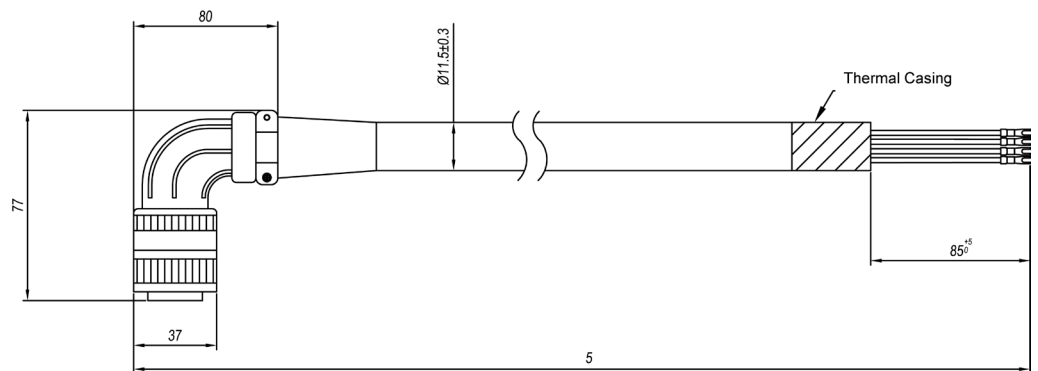

KNC-SRV-MOT-040-05-KC5		
Cable Color	Signal	PIN #
Yellow	U	PINA
Red	V	PINE
Green	W	PINC
Yellow-green	PE	PINF
Shield	Shield	Metal Ring

# KNC-SRV-SMH110D-0120 Motor Specifications



WIRING PINOUTS

Motor Cable with Brake Cable: KNC-SRV-MOT-040-05-KC5-B for KNC-SRV-SMH110D-0120-30ABK-4DKR

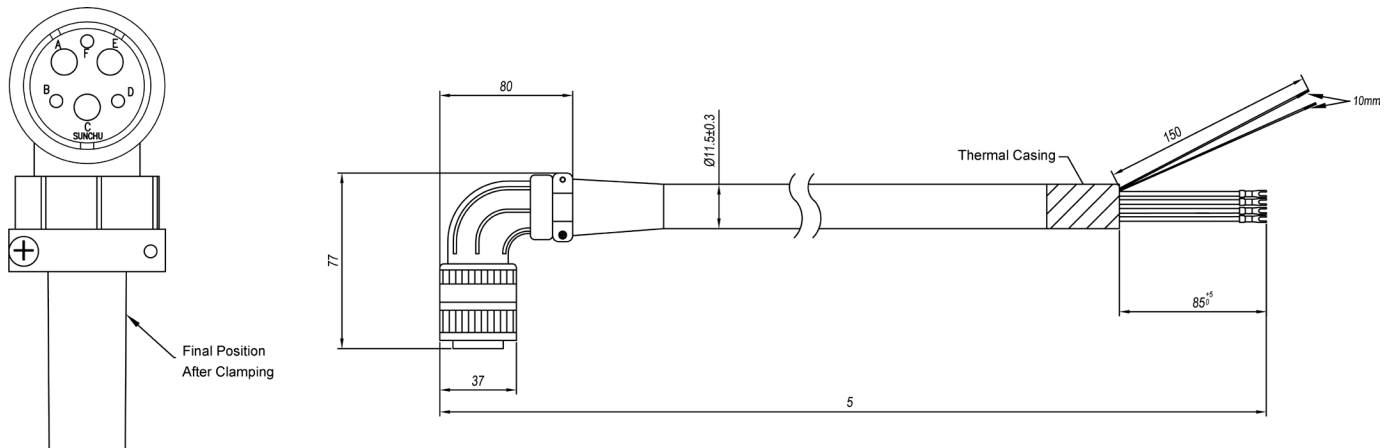

KNC-SRV-MOT-040-05-KC5-B		
Cable Color	Signal	Pin #
Yellow	U	PINA
Red	V	PINE
Green	W	PINC
Yellow/Green	PE	PINF
Red	Brake+	PINB
Blue	Brake-	PIND
Shield	Shield	Shield

# KNC-SRV-SMH110D-0120 Motor Specifications



Encoder Cable: KNC-SRV-ENCHA-05-KC0 for KNC-SRV-SMH110D-0120-30AAK-4DKR and KNC-SRV-SMH110D-0120-30ABK-4DKR

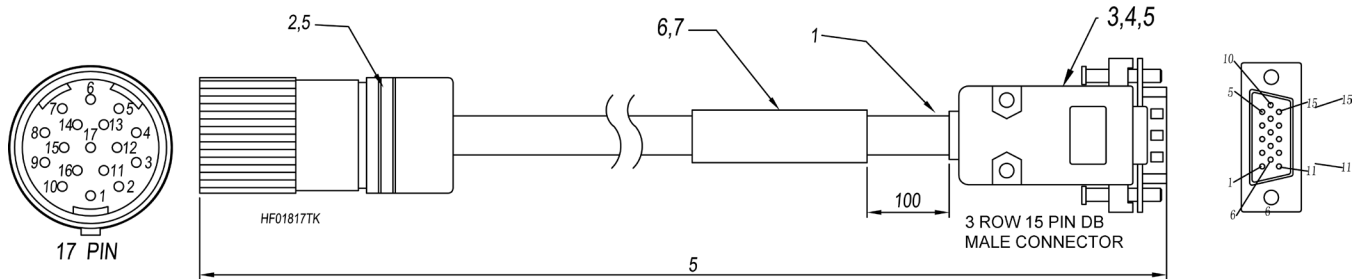

KNC-SRV-ENCHA-05-KC0			
17 PIN Connector	3 Row 15 PIN DB	Signal	Color
PIN1	PIN1	+5V	Red
PIN3	PIN8	A	Orange
PIN5	PIN7	B	Yellow
PIN14	PIN6	Z	Green
PIN9	PIN4	U	Brown
PIN11	PIN10	V	Purple
PIN16	PIN9	W	Blue
PIN2	PIN2	GND	Black
PIN4	PIN13	/A	Orange/White
PIN6	PIN12	/B	Yellow/White
PIN15	PIN11	/Z	Green/White
PIN10	PIN5	/U	Brown/White
PIN12	PIN15	/V	Purple/White
PIN17	PIN14	/W	Blue/White
PIN7	PIN3	PTC/KTY+	Red
PIN8	PIN2	PTC/KTY-	Red/White
Shield			Shield

Communication Cable: KNC-SRV-RS-232-RJ45 for KNC-SRV-SMH110D-0120-30AAK-4DKR & KNC-SRV-SMH110D-0120-30ABK-4DKR

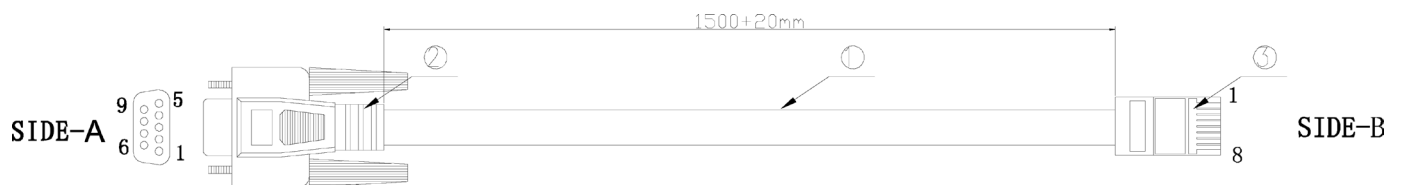

KNC-SRV-RS-232-RJ45							
SIDE-A	2	3	4	5	6	7	8
SIDE-B	3	6	7	4	5	2	8

WIRING PINOUTS

# KNC-SRV-FD144S Driver Specifications



## FEATURES

- 24-70VDC
- Rated Current is 30A (RMS), Peak Current is 120A
- 1200-1500 Watt Rated Power Range
- Position, Speed, and Torque Control
- RS232 and RS485 Port
- Natural Air Cooling
- MODBUS RTU or Pulse and Direction
- Supports Incremental or 16-Bit Absolute Encoders
- Communication Software
  - Configure Parameters
  - I/O Signal Monitoring
  - Speed and Position Curves
  - Gain Adjustments
- Programmable Inputs and Outputs
  - 3 Inputs
  - 2 Outputs (1 Standard & 1 for Brake)
- CE Certified



## DIMENSIONS

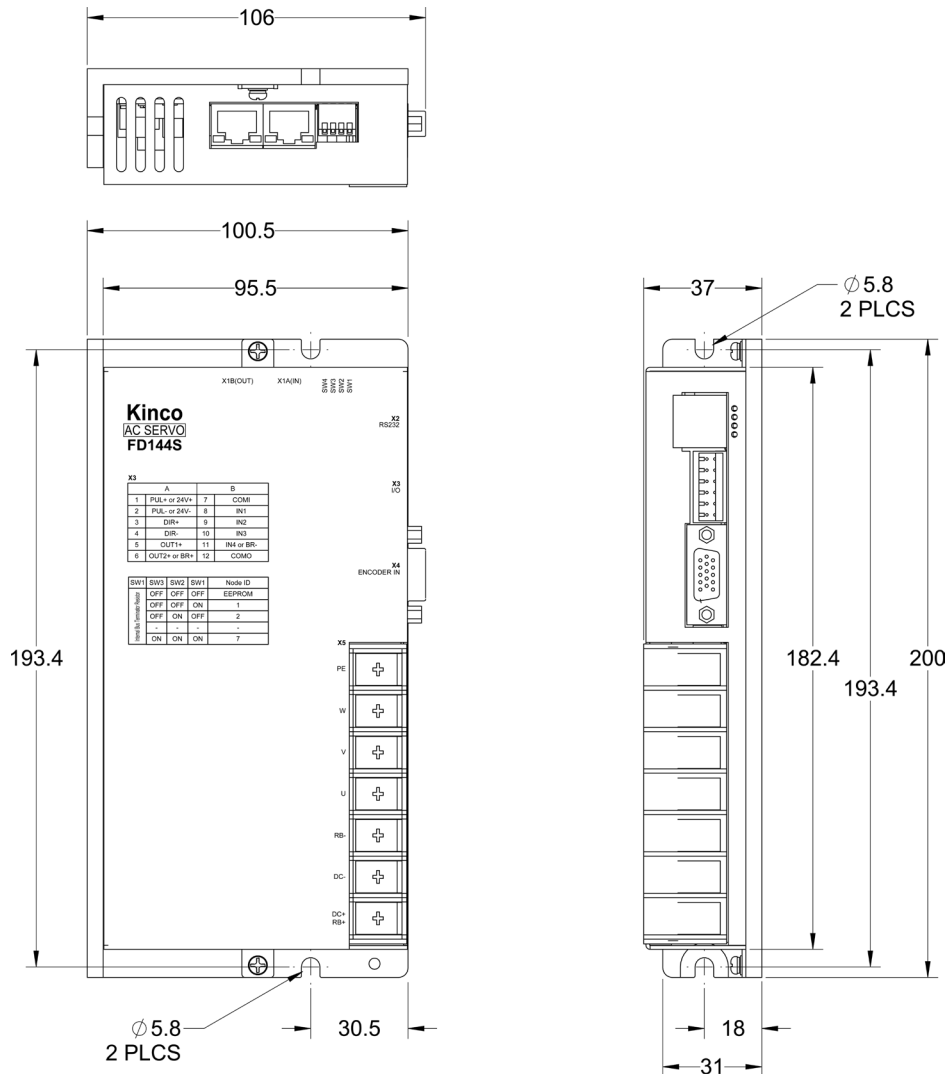

Dimensions are in mm

**RS485 Port**

PIN Number	Signal
8	GND
7	NC
6	NC
5	TX+
4	TX-
3	NC
2	RX-
1	RX+

RS485 Bus Communication Port ————— X1

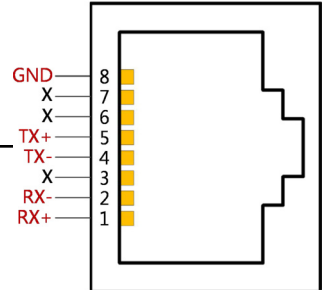
**RS232 Port**

PIN Number	Signal
3	TX
4	GND
6	RX
Others	NC

RS232 Communication Interface, Can be Used for Debugging and Import/Export Project Data Via PC ————— X2

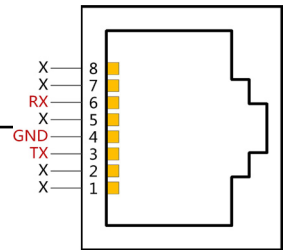
**External Input & Output**

PIN No.	Signal	PIN No.	Signal
1	PUL+	7	COMI
2	PUL-	8	IN1
3	DIR+	9	IN2
4	DIR-	10	IN3
5	OUT1+	11	IN4 / BR-
6	OUT2+ / BR+	12	COMO

Digital Input/Output Terminals ————— X3

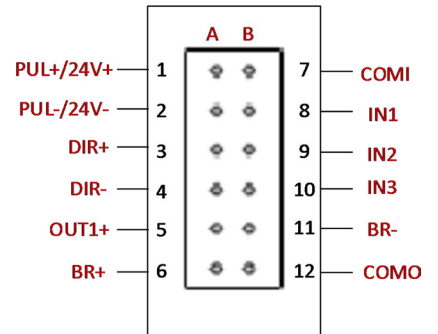
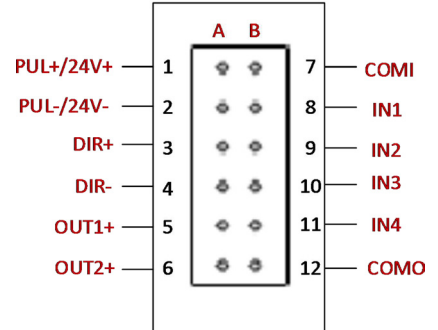
**FD1X4S-□B-000**

**FD1X4S-□A-000**



### Motor with Incremental Encoder

PIN No.	Signal	PIN No.	Signal
1	GND	9	5V+
2	/A	10	A
3	/B	11	B
4	/Z	12	Z
5	/U	13	U
6	/V	14	V
7	/W	15	W
8	PE	16	-

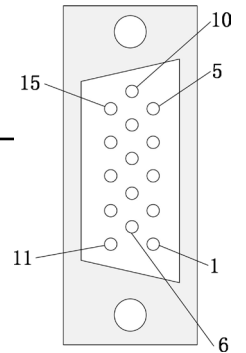
Motor Encoder Input Interface X4



### Motor/Power Supply

PIN Name	PIN Function
PE	Servo Motor UVW phase out and motor ground
W	
V	
U	
RB-	External brake resistor input
DC-	Driver power input negative
DC+ / RB+	Driver power input positive
RB+	External brake resistor input

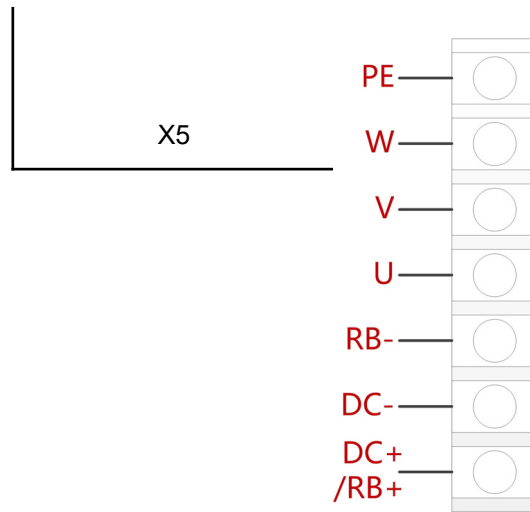

Model Parameter		KNC-SRV-FD144S Series
Power	Main Supply Voltage	24VDC-70VDC
	Control Circuit Voltage	DC24V 1A (Optional)
Current	Rated Current (RMS)	30Arms (40Arms with External Heatsink)
	Peak Current (PEAK)	120A
Feedback Signal		5V Incremental Differential Encoder 16-Bit Single-Turn Magnetic Encoder
Brake Chopper		Via Wiring an External Braking Resistor (Mainly in Quick Start and Stop Application). Brake Chopper Threshold is 73V (Adjustable via Software)
Brake Chopper Threshold		DC73V ± 2V (Default Value, Adjustable via Software)
Over-Voltage Alarming Threshold		DC83V ± 2V
Under-Voltage Alarming Threshold		18V ± 2V
Cooling Method		Natural Air Cooling Note: External Heatsink is Required when the Rated Current of FD124S, FD134S and FD144S Should be Bigger than 12Arms, 20Arms and 30Arms Respectively. The Size of External Heatsink is 300mm*300mm*10mm in Length*Width*Height
Weight		2.4 lbs
Digital Input	Input Specification	3 Digital Inputs, with COM1 Terminal for PNP (High Level Valid 12.5-30V) or NPN (Low Level Valid 0-5V) Connection, Suitable to FD1x4S-LB-000 4 Digital Inputs, with COM1 Terminal for PNP (High Level Valid 12.5-30V) or NPN (Low Level Valid 0-5V) Connection, Suitable to FD1x4S-LA-000
	Input Function	Define Freely According to Requirement, Supporting Following Functions: Driver Enable, Driver Fault Reset, Driver Mode Control, Speed Loop Proportional Control, Positive Limit, Negative Limit, Homing Signal, Reverse Command, Internal Speed Section Control, Internal Positive Section Control, Quick Stop, Start Homing, Active Command, Switch Electronic Gear Ratio, Switch Gain.
Digital Output	Output Specification	1 - Way Digital Output without 1 Driving Capacity of 100 ma or (BR+/BR-) can Directly Drive the Standard Brake Motor for FD1x4S-LB-000, Please Refer to the Wiring Port for Details. 2 - Way Digital Output without 1 Driving Capacity of 100 ma, Suitable for FD1x4S-LA-000.
	Pulse Direction Output	Pulse + Direction, CCW+CW, Phase A+Phase B (5V~24V) Note, only FD1x4-Lx-000 Support this Function
	Output Function	Define Freely According to Requirement, Supporting Following Functions: Driver Ready, Driver Fault, Position Reached, Motor at Zero Speed, Motor Brake, Motor Speed Reached, Z Signal, Maximum Speed Obtained in Torque Mode, Motor Brake, Position Limiting, Reference Found.
	RS232	Default Baudrate Setting is 38400, the Max. Baudrate is 115.2KHz, use Kinco Software to Communicate with PC, or via Free Protocol to Communicate with Controller.
	Protection Function	Over-Voltage Protection, Under-Voltage Protection, Motor Over-Heat Protection (I <sup>2</sup> T), Short-Circuit Protection, Drive Over-Heat Protection, Etc.
Modbus / RS485		The Max. Baudrate is 115.2KHz, use Modbus RTU Protocol to Communicate with Controller.
CAN BUS		Support Maximum 1MHz Baudrate. Communicate with Controller via CANopen Protocol
Ethercat		Support CoE(CiA402 Protocol) and CSP/CSV/PP/PV/PT/HM Mode, Communication Speed 100M

### Compatible Drivers

Part Number	Description
KNC-SRV-FD144S-LB-000	Servo Driver



### Compatible Motors

Part Number	Description
KNC-SRV-SMH110D-0120-30AAK-4DKR	Servo Motor
KNC-SRV-SMH110D-0120-30ABK-4DKR	Servo Motor



### Compatible Cables

Part Number	Description
KNC-SRV-MOT-040-05-KC5	Power Cable
KNC-SRV-MOT-040-05-KC5-B	Power Cable with Brake
KNC-SRV-ENCHA-05-KC0	Encoder Cable
KNC-SRV-RS-232-RJ45	Communication Cable

