

KNC-SRV-iSMK40 Integrated Servo System



FEATURES

- 100 Watt
- 24-60VDC
- RS485, CANopen (AA), EtherCAT (EA)
- 40mm Frame Size
- Singleturn Magnetic Encoder
- 3000 RPM Rated Speed
- 45.3 oz-in Rated Torque
- Modbus RTU or CANopen
- Position and Speed Control
- 24V Logic Power Supply



DESCRIPTION

The KNC-SRV-iSMK40 Integrated Servo System includes a 100 Watt Servo Motor, operated by the Servo Drive. Each system includes a Servo Motor size of 40mm square, power rating of 100 Watts, with a Servo Drive attached to the top of the Servo Motor. These packages are ideal and provide easy start-ups, convenience, and performance. The Servo Motors included in these packages provide torque up to 135.9 oz-in. The Servo Drive is designed to switch dynamically among different control methods for more flexible operation and can operate position control mode either with pulse and direction inputs, internal position points, or internal speed points.

DESCRIPTION

| Item | Rated Output Power (Watts) | Rated Voltage (VDC) | Rated Speed (RPM) | Rated Torque (oz-in) | Rated Current (Arms) | Inertia (oz-in-sec ²) | Peak Torque (oz-in) | Max Speed (RPM) | Brake (24VDC) | Motor Length (mm) | Shaft Diameter (mm) |
|--------------------------------|----------------------------|---------------------|-------------------|----------------------|----------------------|-----------------------------------|---------------------|-----------------|---------------|-------------------|---------------------|
| KNC-SRV-ISMK40-010-DMAK-AA-000 | 100 | 48 | 3000 | 45.3 | 2.8 | 0.000623 | 135.9 | 4000 | No | 90 | 8.0 |
| KNC-SRV-ISMK40-010-DMBK-AA-000 | 100 | 48 | 3000 | 45.3 | 2.8 | 0.000651 | 135.9 | 4000 | Yes | 126 | 8.0 |
| KNC-SRV-ISMK40-010-DMAK-EA-000 | 100 | 48 | 3000 | 45.3 | 2.8 | 0.000623 | 135.9 | 4000 | No | 90 | 8.0 |
| KNC-SRV-ISMK40-010-DMBK-EA-000 | 100 | 48 | 3000 | 45.3 | 2.8 | 0.000651 | 135.9 | 4000 | Yes | 126 | 8.0 |

ORDERING INFORMATION

KNC-SRV-iSMK40-010-DMAK-AA-000

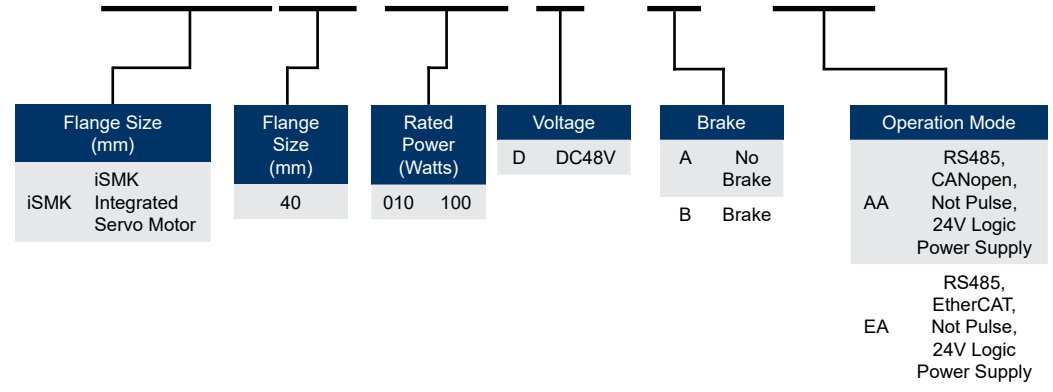

L012016

DIMENSIONS

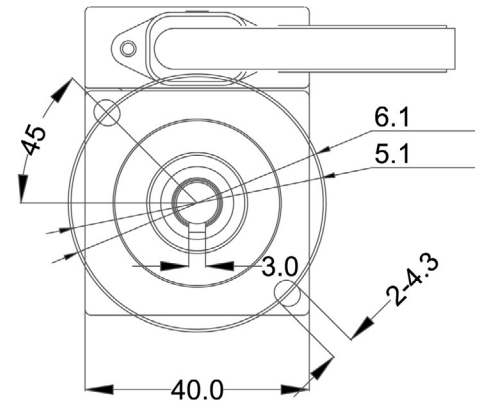
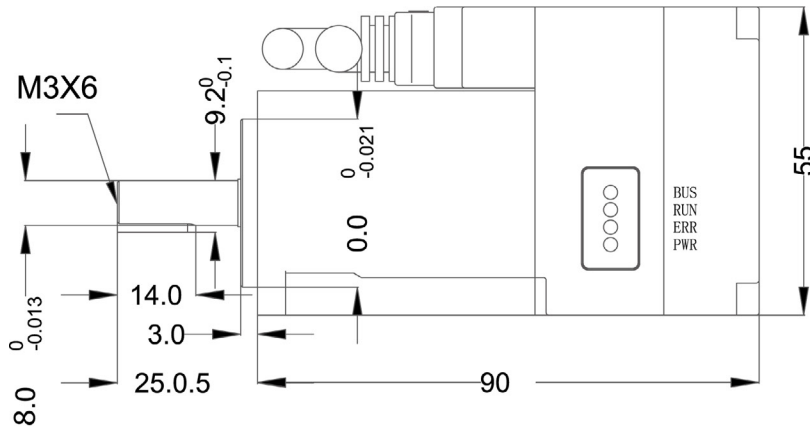

Units are in mm

TORQUE CURVE

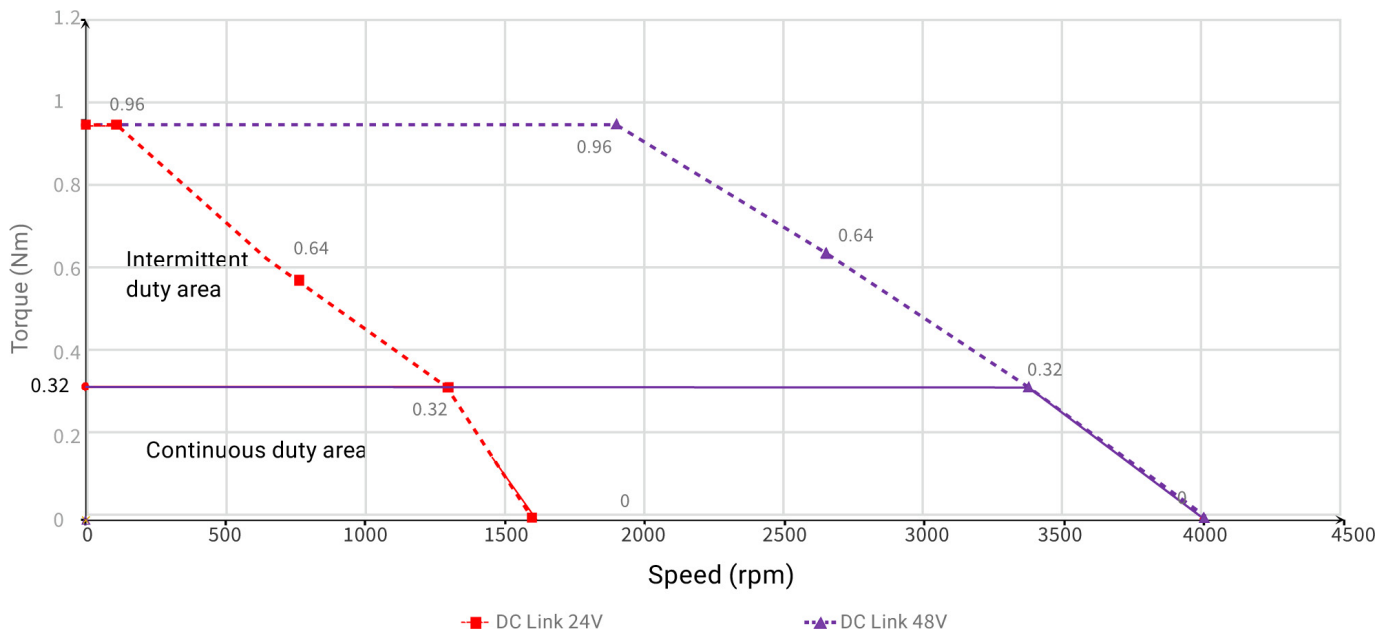

L012016

INTERFACE DESCRIPTION

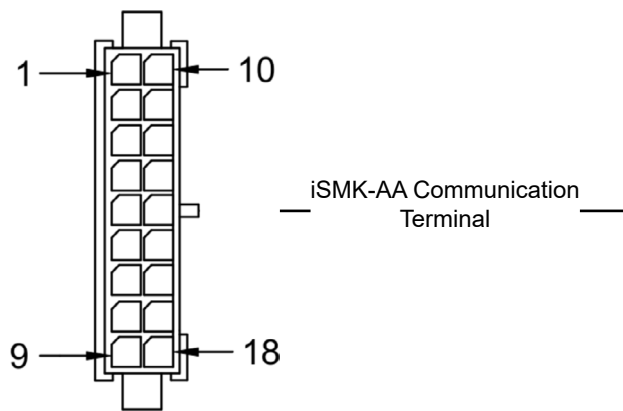

| A | | | B | | |
|-----|--------|------------------|-----|--------|------------------|
| Pin | Name | Cable Color | Pin | Name | Cable Color |
| 1 | 24V | Red | 10 | GND | Black |
| 2 | LOCK+ | Purple | 11 | LOCK- | Purple and Black |
| 3 | CANH | Blue and Black | 12 | CANL | Blue |
| 4 | CANH | Blue and Black | 13 | CANL | Blue |
| 5 | RS485A | Orange and Black | 14 | RS485B | Orange |
| 6 | RS485A | Orange and Black | 15 | RS485B | Orange |
| 7 | OUT1+ | Yellow and Black | 16 | COMO | Yellow |
| 8 | COMI | White | 17 | DI1 | Green |
| 9 | GND | Green and Black | 18 | DI2 | White and Black |

L012016

KNC-SRV-iSMK40 Integrated Servo System



INTERFACE DESCRIPTION

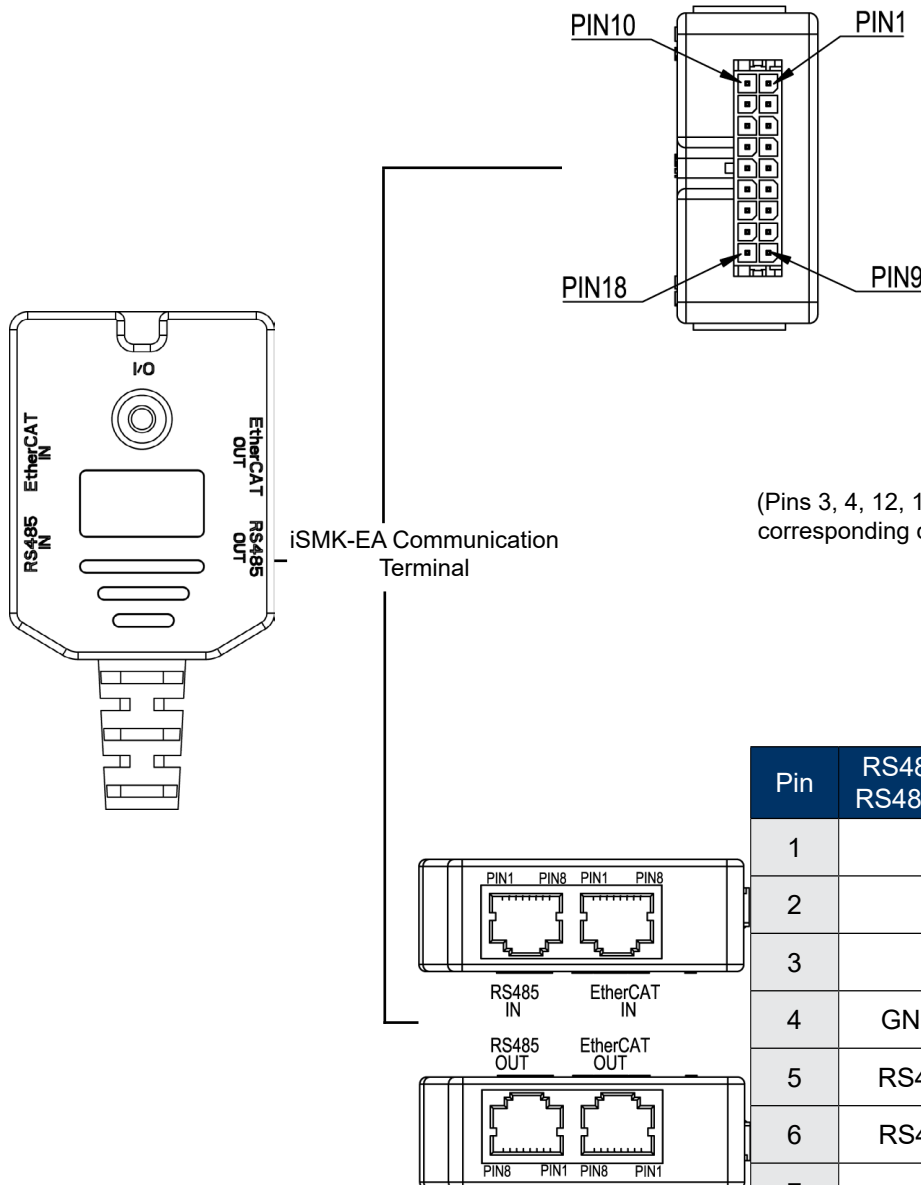

| A | | B | |
|-----|--------|-----|--------|
| Pin | Signal | Pin | Signal |
| 1 | 24V | 10 | GND |
| 2 | LOCK+ | 11 | LOCK- |
| 3 | / | 12 | / |
| 4 | / | 13 | / |
| 5 | RS485A | 14 | RS485B |
| 6 | RS485A | 15 | RS485B |
| 7 | OUT1+ | 16 | COMO |
| 8 | COMI | 17 | DI1 |
| 9 | GNDC | 18 | DI2 |

(Pins 3, 4, 12, 13 of the iSMK-EA series are empty, and the corresponding color cable of these four pins of the external cable can be ignored)

| Pin | RS485 IN / RS485 OUT | EtherCAT IN | EtherCAT OUT |
|-----|----------------------|-------------|--------------|
| 1 | / | IN TX+ | OUT TX+ |
| 2 | / | IN TX- | OUT TX- |
| 3 | / | IN RX+ | OUT RX+ |
| 4 | GND_C | / | / |
| 5 | RS485B | / | / |
| 6 | RS485A | IN RX- | OUT RX- |
| 7 | / | / | / |
| 8 | / | / | / |

L012016

| Signal | Function Description |
|--------|--|
| 24V | The logic power supply is an optional option. When using the logic power supply, ensure that the power supply and logic are completely isolated. If the system power supply is not isolated, the logical ground cable is not connected. The logic power supply is connected at DC- and V |
| GND | Logic electrical reference ground |
| LOCK+ | External release beake input The input voltage is V, the maximum input current is . A, only when the AGV body battery is out of emergency use; |
| LOCK- | Only when both the logic power supply and the power supply are powered off, the external lock can be unlocked. Do not short-circuit or connect to other signals and enclosures during normal operation |
| CANH | CAN signal positive end(Only the iSMK-AA series has this terminal) |
| CANL | CAN signal negative end(Only the iSMK-AA series has this terminal) |
| 485A | RS485 data positive end |
| 485B | RS485 data negative end |
| GND_C | Signal ground |
| DIN1 | Digital signal input;High level: . VDC~ VDC Low level: VDC~VDC Input impedance: KΩ Input frequency: <KHz |
| DIN2 | Digital signal input;High level: . VDC~ VDC Low level: VDC~VDC Input impedance: KΩ Input frequency: <KHz |
| COMI | Digital signal input to the common end |
| OUT1+ | Digital signal output; digital output, maximum output current: mA |
| COMO | Digital signal output common terminal |

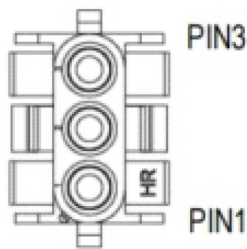

Power Cable Port

| Power Line Terminal C6350HM-3P-V0 | Signal | Color |
|--------------------------------------|--------|-------|
| 1 | 48V+ | Red |
| 2 | / | / |
| 3 | 48V- | Black |

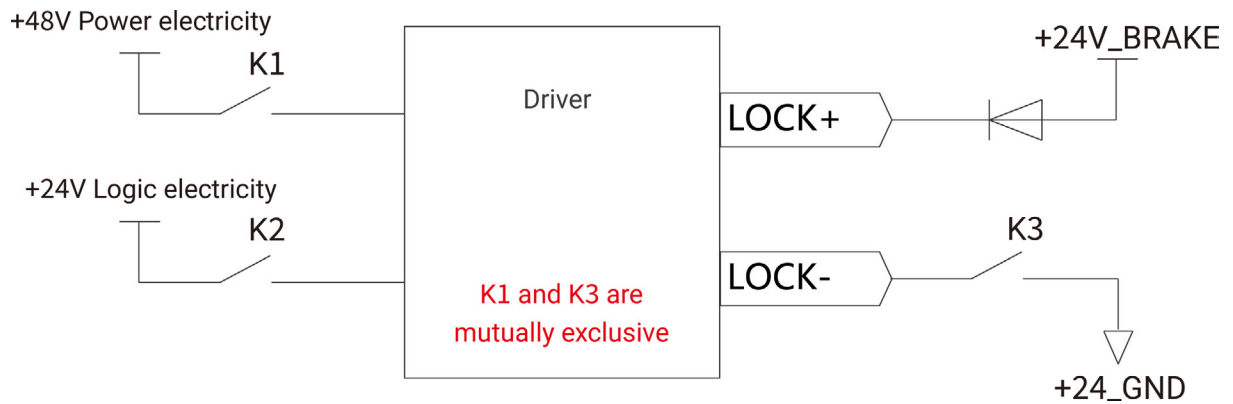

(Note: After cutting off the iSMK logic and power supply, use the power supply)

L012016

KNC-SRV-iSMK40 Integrated Servo System



TECHNICAL SPECIFICATIONS

| Model Parameter | | KNC-SRV-iSMK40 Series |
|----------------------------------|-----------------------|---|
| Power | Main Supply Voltage | DC24V~60V |
| Current | Rated Current (A) | 2.8 (A) |
| | Peak Current (PEAK) | 8.4 (A) |
| Weight (lbs) | | 1.32 lbs KNC-SRV-ISMK-40-010-DMAK-AA-000 1.76 lbs KNC-SRV-ISMK-40-010-DMBK-AA-000 1.54 lbs KNC-SRV-ISMK-40-010-DMAK-EA-000 1.98 lbs KNC-SRV-ISMK-40-010-DMBK-EA-000 |
| Logic Loss Power (mW) | | 900 |
| Feedback Signal | | Singleturn Communication Type Magnetoelectric Encoder |
| Energy Consumption Brake | | There is no brake circuit inside the driver, and an external brake module is required. |
| Over-Voltage Alarming Threshold | | Default is 70V |
| Under-Voltage Alarming Threshold | | Default is 18V |
| Cooling Method | | Natural Air Cooling |
| Input Specification | | 2 Digital Inputs, High: 12.5VDC~30VDC Low: 0VDC~5VDC Input Impedance: 5KΩ Input Frequency: <1KHz |
| Input Function | | Freely defined as required, the functions are as follows: drive enable, drive error reset, drive mode control, speed loop proportional control, positive limit, negative limit, origin signal, command reverse, internal speed segment control, internal position segment control, emergency stop, start to find the origin, command activation, electronic gear ratio switching, gain switching. |
| Output Specification | | 1 Digital Output, OUT1 for the open collector output, the highest voltage 30V, driving capacity of 100mA |
| Output Function | | Freely defined according to needs, the functions are as follows: driver ready, driver error, motor position to, motor zero speed, motor lock brake, motor speed to, index Z signal appears, maximum limit speed in torque mode, motor lock shaft, motor limit medium, origin finding. |
| RS485 | | It supports a maximum . Kbps baud rate and can communicate with the controller using the Modbus RTU. |
| CANopen | | It supports a maximum Mbps baud rate and can communicate with the controller using the CANopen. |
| EtherCAT | | Support CoE(CiA protocol)and CSP/CSV/PP/PV/PT/HM mode, communication speed M |
| Operation Environment | Operating Temperature | -20 ~ 40°C (No Freezing) When the operating temperature exceeds 40°C, the driver needs to be derated. |
| | Operating Humidity | Less than 90%RH (No Condensation) |
| | Storage Temperature | -40°C~70°C (No Freezing) |
| | Storage Humidity | 90%RH (No Condensation) |
| | Protection Class | IP65, Shaft End IP54 |
| | Installation Method | Motor Flange Installation (Vertical Side Installation) |
| | Altitude | Rated Working Altitude at 1000m or Below, Above 1000m: Decreasing 1.5% per 100m Rise, Maximum Altitude 2000m Above Sea Level |
| | Atmospheric Pressure | 86kpa~106kpa |

L012016