

# KNC-IWMC10411 Integrated Servo Wheel

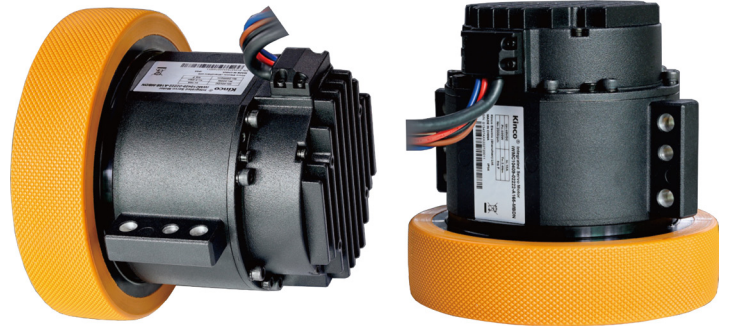

## FEATURES

- 24-60VDC
- 180mm Wheel Frame Size
- 104mm Motor Frame Size
- Singleturn Magnetic Encoder
- 2.14m/s Rated Linear Speed
- 5664 oz-in Rated Torque
- Standard CANopen Communication
- Position and Speed Control
- 24V Logic Power Supply



## DESCRIPTION

The KNC-IWMC10411 Integrated Servo Wheel includes a Servo Driver, Servo Motor, Gearhead and Rubber Wheel, all highly integrated in one unique product. This Integrated Servo Wheel creates a compact Servo System which uses less space than a typical Servo System, facilitating downsizing. These packages are ideal and provide easy start-ups, convenience, and performance. The Servo Motors included in these packages provide torque up to 14019 oz-in. The Servo Drive is designed to switch dynamically among different control methods for more flexible operation and can operate in position control mode with either pulse and direction inputs, internal position points, or internal speed points.

## SPECIFICATIONS

Item	Rated Output Power (Watts)	Rated Voltage (VDC)	Rated Speed (RPM)	Rated Torque (oz-in)	Max Current (Arms)	Peak Torque (oz-in)	Brake (24VDC)	Overall Length (mm)	Tire Diameter (mm)	Tire Width (mm)	Weight (lbs)
KNC-IWMC10411-04023-A180-MADT	1000	24VDC	2500	5664	26A	14019	No	184±1.5	180	50	28.2
KNC-IWMC10411-04023-A180-MBDT	1000	24VDC	2500	5664	26A	14019	Yes	184±1.5	180	50	28.2

## ORDERING INFORMATION

# KNC-IWMC10411-04023-A180-MADT

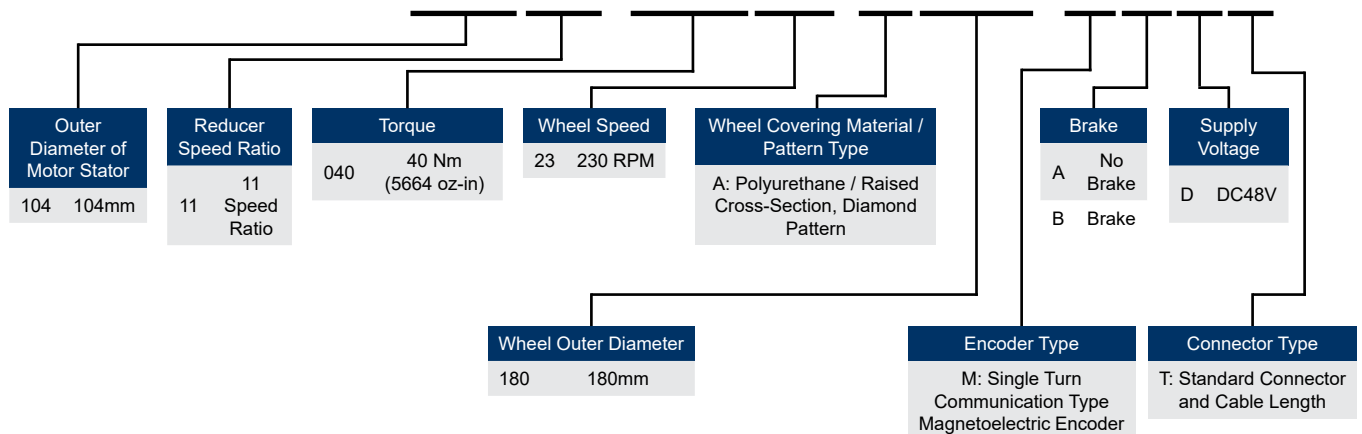

L012025

# KNC-IWMC10411 Integrated Servo Wheel



## DIMENSIONS

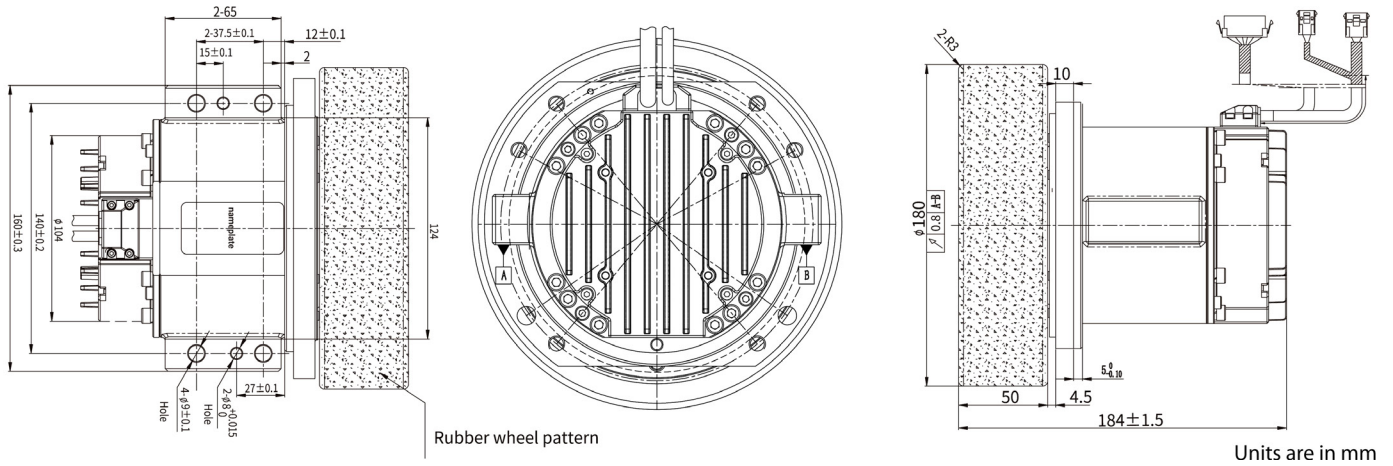

## INTERFACE DESCRIPTION

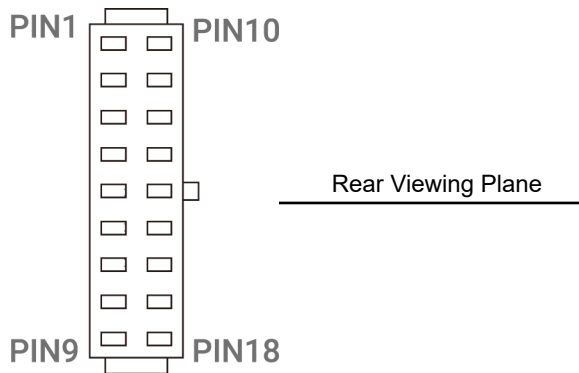

Pin	Signal	Pin	Signal
1	24V	10	GND
2	LOCK+	11	LOCK-
3	CANH	12	CANL
4	CANH	13	CANL
5	485A	14	485B
6	485A	15	485B
7	OUT1+	16	COMO
8	COMI	17	DI1
9	Empty	18	DI2

L012025

# KNC-IWMC10411 Integrated Servo Wheel



INTERFACE DESCRIPTION

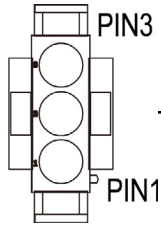

Power Port

Pin	Name	Function
3	DC-	The input end of the power supply of the driver must be connected
1	DC+	Input voltage: 24~60VDC

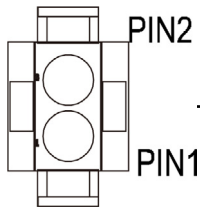

Brake Resistance Port

Pin	Name	Function
1	RB+	External braking resistor input terminal
2	RB-	

WIRING DIAGRAM

IWMC Integrated Servo Wheel Control Wiring Diagram

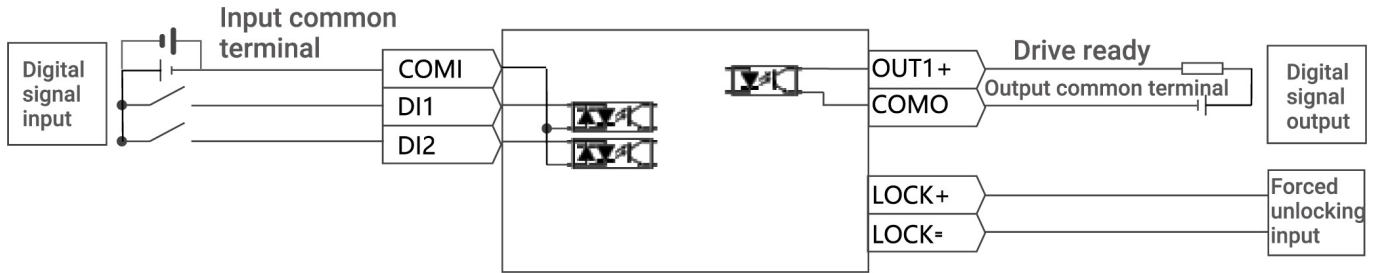

Wiring Diagram of Recommended Circuit for Forced Unlocking Brake

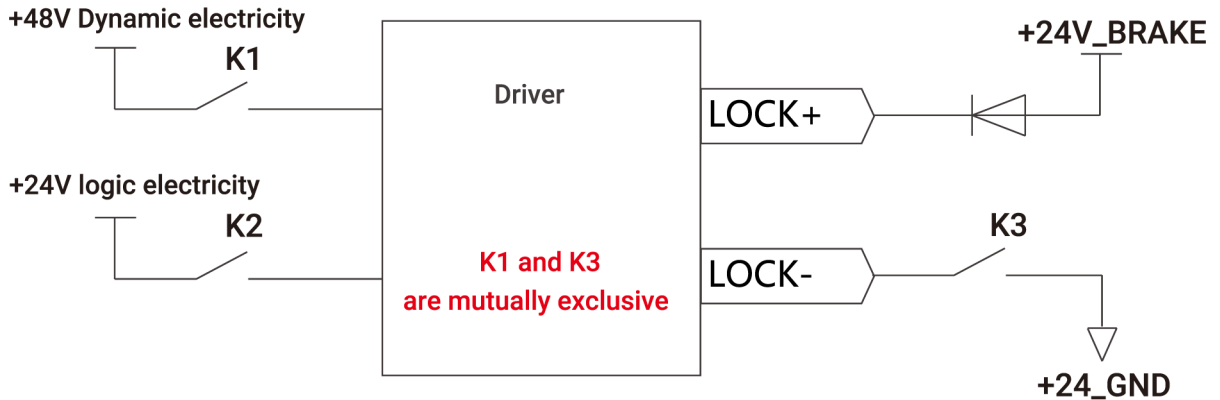

**Note: The forced unlocking function needs to be used after the power supply of the servo wheel is cut off.**

L012025

# KNC-IWMC10411 Integrated Servo Wheel



TECHNICAL SPECIFICATIONS

Model Parameter		KNC-IWMC10411 Series
Power	Power Supply	DC24V~60V
	Logic Supply	24VDC
Rated Linear Speed (m/s)		2.14 (m/s)
Rated Torque (oz-in)		5664 (oz-in)
Peak Torque (oz-in)		14019 (oz-in)
Tire Diameter (mm)		180 (mm)
Tire Width (mm)		50 (mm)
Tire Material		Polyurethane
Tire Hardness Rating		90A
Energy Consumption Rating		External braking resistor is required (depending on the operating conditions, mainly used for rapid starting and stopping).
Energy Consumption Braking Voltage Absorption Point		DC63V ± 2V (Default, settable)
Overvoltage Alarm Point		DC68V ± 2V
Undervoltage Alarm Point		DC18V ± 2V
Input Specifications		2 Digital Inputs / Common COMI Terminal / High Level: 12.5-30VDC / Low Level: 0-5VDC / Maximum Frequency: 1KHZ / Input Impedance: 5KΩ.
Output Specifications		1 Digital Output Common COMO Terminal / Maximum Output Current: 100mA
Brake		Built-In Brake and Control Circuit
Forced Unlock Interface		1-way forced unlock interface, only for use when there is no power input to the servo wheel.
RS485 Debug Port		Maximum support for 115.2Kbps baud rate
CAN BUS		Maximum support for 1Mbps baud rate, CANopen protocol can be used to communicate with the controller.
Drive Current	Max. Continuous Output Current (rms)	26A
	Peak Current	100Ap(<2s)
Motor	Rated RPM	2500 RPM
	Rated Torque (oz-in)	566 (oz-in)
	Brake Holding Torque (oz-in)	566 (oz-in)
Noise		<65dB
Cooling Methods		Natural cooling & body-assisted cooling.
Operation Environment	Operating Temperature	0°C ~ 40°C
	Humidity (non-condensing)	Less than 90%RH
	Storage Temperature	-20°C ~ 60°C
	Protection Class	IP54
	Altitude	Rated Working Altitude at 1000m or Below, Above 1000m: Decreasing 1.5% per 100m Rise, Maximum Altitude 2000m Above Sea Level
	Atmospheric Pressure	86kpa~106kpa

L012025