

# DPC50501 Programmable Driver Pack

## User's Guide



**A N A H E I M A U T O M A T I O N**

4985 E. Landon Drive Anaheim, CA 92807  
e-mail: [info@anaheimautomation.com](mailto:info@anaheimautomation.com)

(714) 992-6990 fax: (714) 992-0471  
website: [www.anaheimautomation.com](http://www.anaheimautomation.com)

# Table of Contents

<b>Section 1: Introduction.....</b>	<b>3</b>
Description.....	3
Ordering Information.....	4
Axis Selection.....	4
Baud Selection.....	5
Baud Rates.....	5
Methods of Communication.....	5
RS232 to RS485 Protocol.....	5
RS485.....	6
Two Wire Configuration.....	6
Four Wire Configuration.....	6
Terminating Resistor.....	7
Status LED (Controller).....	7
Technical Support.....	7
Electrical Specifications.....	8
Terminal Descriptions.....	8
Dimensions.....	9
Wiring Diagram.....	9
Motor Selection.....	10
Step Motor Selection Guide.....	11
Reducing Output Current.....	11
Determining Output Current.....	11
Step Motor Configurations.....	12
Connecting the Step Motor.....	13
Short-Circuit, Mis-Wire, and Over-Current Conditions.....	13
<b>Section 2: Controller Functions.....</b>	<b>14</b>
<b>Section 3: SMC50WIN Software.....</b>	<b>17</b>
Installation.....	17
Getting Started.....	17
“The Unit is Connected” / “The Unit is NOT Connected”.....	18
File Menu.....	18
Setup Menu.....	18
Toolbar.....	18
Tab Sheets.....	19
Current Program Filename.....	21
Add/Change/Insert Commands.....	21
Calculator.....	25
<b>Section 4: Direct Talk Mode.....</b>	<b>26</b>
COM Port Settings.....	26
Unit Selection.....	26
Instructions.....	26
<b>Section 5: Troubleshooting.....</b>	<b>31</b>
Error Codes.....	32
<b>Section 6: Tutorial.....</b>	<b>33</b>
Sample Program 1:.....	33
Sample Program 2:.....	34
Appendix 1: ASCII Table for Direct Mode.....	36
Copyright.....	37

## Section 1:

### Introduction

The DPC50501 is a single axis programmable controller, a 5 amp bipolar microstep driver, and a 48VDC 65W power supply package. It provides flexible, independent control of bipolar step motors with a current range from 0.5 to 5.0 amps and microstepping resolutions of 1, 2, 5, 8, 10, 16, 32 and 64. The easy to use software, SMC50WIN, can be used to directly control motion and to program the controller. The DPC50501 also has the ability for real time functions. A “direct mode” is used to directly control motion for real time movements through serial communication. The DPC50501 has 20 commands which are easy to remember for direct movement and uses the RS485 communication protocol so up to 32 units can be networked together from one communications port on your PC or PLC (programmable logic controller). The DPC50501 also has 2 programmable “open drain” outputs and 4 TTL compatible inputs and can be powered from 105 VAC to 130VAC. The DPC50501 is direct replacement in size and connections with Anaheim Automation’s DPC40501. The upgrades to this unit include higher resolution and higher motor currents.

### Description

Generally step motor controllers are open-loop systems, meaning that no information is sent back to the controller from the motor to verify the number of steps that were taken. A step motor is essentially a digital device - you give the step motor driver 10 step pulses, and the motor moves 10 steps. The DPC50501 provides independent programming of acceleration/deceleration, base speed (start up speed), max speed (running speed), and the number of steps to both relative and absolute positioning modes. On absolute positioning moves, the controller automatically determines the proper direction to go and the number of steps to take. The relative positioning will move a number of steps in the direction that the user defines. The controller has a high level command set including: looping, conditional statements, time delays, and I/O. Hard, soft, and home limit switch inputs are provided for each axis. These features are generally required in most machine control designs. Four testable inputs and 2 programmable outputs are provided per axis. These I/O are accessible independent of the busy state of the axis controls. The 4 inputs are TTL/CMOS compatible. The 2 outputs are current sinking, open drain FETs. The controller in the DPC50501 has a built-in programmable reset circuit. Reset is automatic on power-up or by pressing the external reset button. A CD is provided when you purchase the unit. This CD contains software that allows you to write and change programs that are to be store in the controller for autostart use. This CD also allows you to save the programs onto your computer hard-drive, and easily retrieve them when needed. The clock and direction outputs of the controller are internally wired to the driver. The “microstep driver” in the DPC50501 has an output current capability of 0.5 amp minimum to 5.0 amps maximum (peak rating). The driver offer motor current ON/OFF capabilities. The Reduce Current Enabled automatically reduces motor current to 50% of the set value after the last step is made (20msec delay). With the DPC50501, various step resolutions can be implemented by the onboard dip switch. These divisions range from 200 steps per revolution to 12800 steps per revolution. The bipolar driver configuration handles 4, 6, and 8 lead motors. Protection devices have been added to this driver for phase to phase short-circuit conditions.

## Ordering Information

The table below lists a variety of products available from Anaheim Automation. These products include those covered by this manual, analog with supporting cables and devices. We are continually adding new products to our line, so please consult Anaheim Automation representatives for information on the latest releases.

Part Number	Description
DPC50501	Featured
PCL501	RS485 compatible controller (Up to 32 unit multidrop compatible)
PCL501PC	RS232 compatible controller (Not multidrop compatible)
485SD9TB	RS232 to RS485 converter
MBC05641	0.5-5 Amp Microstep Driver
PSAM24V1.2A-5V3.5A	Power supply for PCL501 and PCL501PC (24V@1.2A, 5V@3.5A)

## Axis Selection

Each controller will be addressed using 5 jumpers (JP4 - JP8) allowing the PC to address up to 32 controllers from one port. The jumpers are considered ON (1) when they are in position "1-2" and OFF (0) when they are in position "2-3". The jumpers are located on the side of the DPC50501. The table below shows how to configure the jumpers for a given axis. JP8 is the LSB (Least Significant Bit) and JP4 is the MSB (Most Significant Bit).

Axis Selected	Jumper Setting	Axis Selected	Jumper Setting
0	00000	16	10000
1	00001	17	10001
2	00010	18	10010
3	00011	19	10011
4	00100	20	10100
5	00101	21	10101
6	00110	22	10110
7	00111	23	10111
8	01000	24	11000
9	01001	25	11001
10	01010	26	11010
11	01011	27	11011
12	01100	28	11100
13	01101	29	11101
14	01110	30	11110
15	01111	31	11111

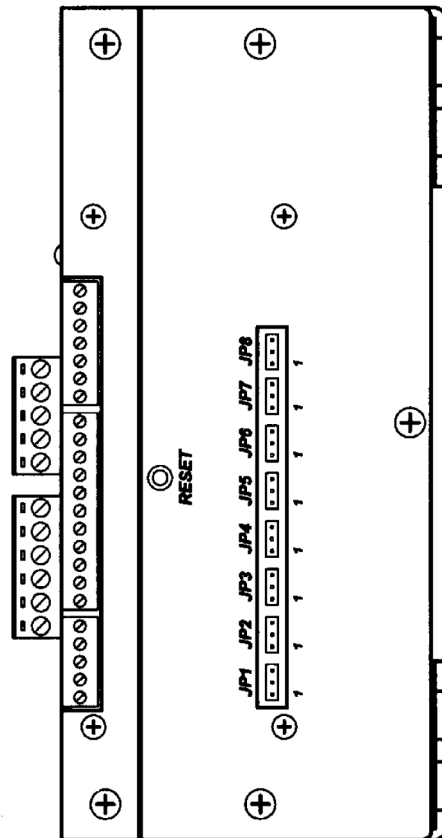

## Baud Selection

The baud rate is selected using 3 jumpers (JP1 - JP3). They are selected the same way that the address jumpers are selected. The table below shows how to configure the jumpers for a given baud rate. JP3 is the LSB and JP1 is the MSB.

Baud Rate	Jumper Setting
1200	000
2400	001
4800	010
9600	011
19200	100
38400	101
57600	110
115200	111

## Baud Rates

A term used frequently in serial data communications. A “baud” is defined as the reciprocal of the shortest pulse duration in a data word signal, including start, stop, and parity bits. This is often taken to mean the same as “bits per second”, a term that expresses only the number of “data” bits per second. Very often, the parity bit is included as an information or data bit. The PCL501 accepts the following baud rates:

1200, 2400, 4800, 9600, 19200, 38400, 57600, 115200

## Methods of Communication

There are two methods for sending commands to the DPC50501’s controller. One is to directly talk to the controller by using Direct Talk Mode. This is usually used with a computer or PLC (Programmable Logic Controller), where the computer or PLC gives the controller serial commands to off-load its processor. For example: A PLC can utilize its outputs to toggle the controller’s inputs and gain control of variable speeds, variable programs, variable distances, etc. Simply using the controller as the intelligent pulse generator a PLC can remove some of the tasks that were not meant for ladder logic or any PLC processing time. The second way to give commands to the controller is to use the software program SMC50WIN to either manually control or write and send programs. This method is used when the controller is the main controller. For example: A DPC50501 can replace simple motion control and replace I/O functional when minimal quantities of I/O are required to control specific machinery. Simple motion profiles that can operate with 4 or less inputs and 2 or less outputs can utilize a DPC50501 controller.

## RS232 to RS485 Protocol

The controller can be connected to your PC serial port via an RS485 or RS422 converter box. The RS232 converter will convert the RS232 communication format to the RS485 or RS422 format. Only one converter box is needed per serial port. Contact the factory for RS485 converter information and sales.

## RS485 Protocol

The RS485 protocol is as follows, onboard receivers will remain in active mode indefinitely. Transmitters must be turned off when the unit is not sending data to prevent the line from sending and receiving data at the same time. Therefore when the PC is transmitting data its driver will be turned on and each of the units connected will have their drivers off. If they are requested to send data back to the PC, the selected unit will turn it's driver on to send the data then turn it off after it has completed transmission. Note: The above protocol is done internally between the converter and controller. The RS485 method of communication allows increased noise immunity and increased communication distance of up to 4000 feet without repeaters. RS485 repeaters allow an additional 4000 feet per repeater.

## Two Wire Configuration

The two wire configuration reduces cabling costs by requiring only three wires. A, B and ground. The DPC50501 is designed to allow either the two or four wire configuration. To use the 2 wire configuration simply wire TX+ to RX+, and TX- to RX- on your converter box. Then run a wire from ground, a wire from TX+/RX+ and a wire from TX-/RX-, to the first controller in the network. Finally do the same on the terminal block of the controller to the converter box. The diagram below illustrates how this configuration is connected. RS422 systems require a dedicated pair of wires for each signal, a transmit pair, a receive pair, and an additional pair for each handshake/control signal used (if required). The tristate capabilities of RS485 allow a single pair of wires to share transmit and receive signals for half duplex communications. This "two wire" configuration (note that an additional ground conductor should be used) reduces cabling cost. RS485 devices may be internally or externally configured for two wire systems. Internally configured RS485 devices simply provide "A" and "B" connections (sometimes labeled "-" and "+").

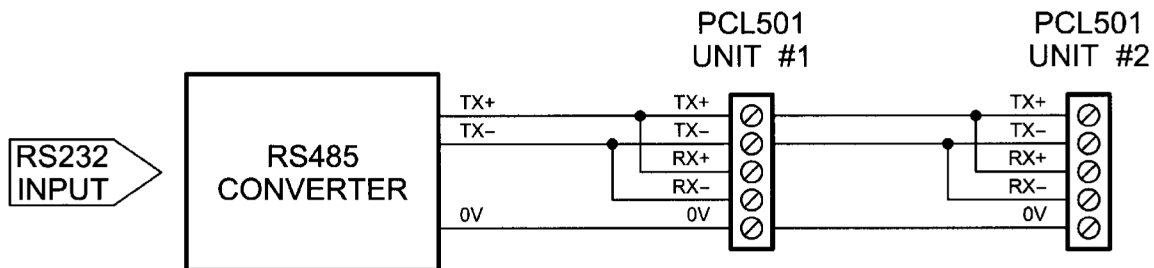

## Four Wire Configuration

Devices configured for four wire communications use TX and RX connections for both the transmit and the receive pairs. The user can connect the transmit lines to the receive lines to create a two wire configuration flexibility. Note that the signal ground line should also be connected in the system. This connection is necessary to keep the VCM common mode voltage at the receiver within a safe range. From the diagram below, it can be seen that all wires are run directly from the converter to the controller. For example TX+ from the converter goes to TX+ on the controller and so on.

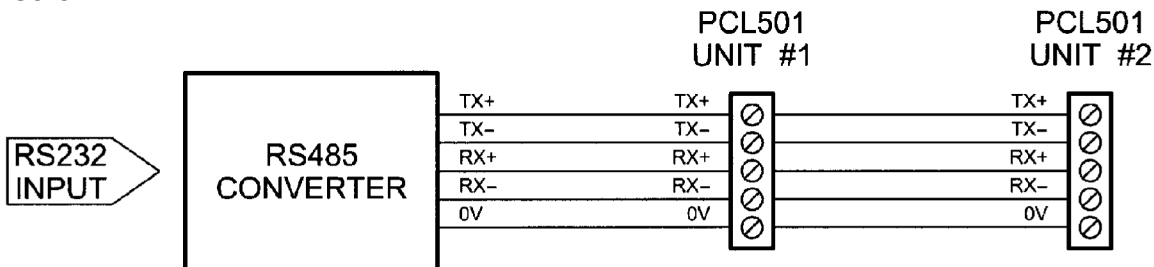

## **Terminating Resistor**

To eliminate noise on the transmission lines a terminating resistor may need to be used. If needed the termination resistor need only be added to the last (furthest from the converter box) controller in the network. A termination resistor with a value of 120 ohms is needed in certain conditions; when using a 4000ft. or longer cable and a baud rate of 38400 or when using a 2000ft. or longer cable and a baud rate of 57600. If you need to add a terminating resistor, contact the factory for the exact location on the board.

## **Status LED (Controller)**

When powered and operated properly, the status LED will green. When an error occurs, the LED will change to RED and an error code will be generated in the error code register. To read and clear the error with the software, click on the “Verify Parameters” button located in the “Motion Tab”. To read and clear the error while in “Direct Mode” use the ! command. Once the error has been read and cleared, the LED will return to green and the error code register will be cleared. Refer to the table in section 5 for a list of the error codes.

## **Technical Support**

Everyone needs help on occasion. If you have problems using any of the equipment covered by this manual, please read the manual to see if it will answer the questions you have. Be sure to look in the troubleshooting section located near the back of this manual. If you need assistance beyond what this manual can provide, you can call the factory direct for application assistance. If possible, have this manual in hand. It is often helpful to have the unit connected to a computer with the software installed.

## Electrical Specifications

### Power Requirements:

110VAC Single Phase

### Operating Temperature:

0° to 60° C

### Pulse Output Range:

77 to 15000 pps

### Inputs (TTL-CMOS):

Logic "0": 0 to 0.8VDC

Logic "1": 3.5 to 5.0VDC

### Baud Rate:

1200 to 115200 BAUD

**Note:** For inductive loads, customers must connect a clamping diode to protect from fly back voltage spikes.

### Driver Ratings:

Output Current 5.0 amps peak

Item	Min	Max	Units
Phase Output Current	0.35	3.5	A (RMS)
Phase Output Current	0.5	5.0	A (Peak)

### Data Format:

Half-Duplex, 1 start bit, 8 data bits, no parity, 1 stop bit

### Outputs (2 programmable I/O):

Open Drain Type

40V, 75mA

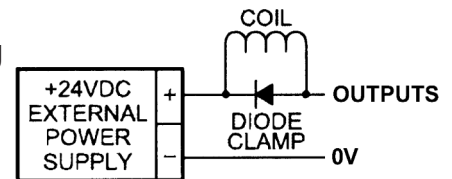

## Terminal Descriptions

### TB1:

Pin #	Description
1	TX+
2	TX-
3	RX+
4	RX-
5	RS485 Ground

### TB2:

Pin #	Description	Comments
1	OUT1	Open Drain
2	OUT2	Open Drain
3	IN1	Active Low = 1
4	IN2	Active Low = 2
5	IN3	Active Low = 4
6	IN4	Active Low = 8
7	0VDC	Reference

### TB4:

Pin #	Description
1	Phase A: Phase 1 of the step motor
2	Phase $\bar{A}$ : Phase 3 of the step motor
3	Phase B: Phase 2 of the step motor
4	Phase $\bar{B}$ : Phase 4 of the step motor
5	MGND: Motor Ground

### TB3:

Pin #	Description	Comments
1	JOG+	Active Low
2	JOG-	Active Low
3	FJOG	Active Low
4	SOFT+	Active Low
5	SOFT-	Active Low
6	HARD+	Active Low
7	HARD-	Active Low
8	HOME	Active Low
9	CLK	Open Drain
10	DIR	Open Drain
11	0VDC	Reference

### TB5:

Pin #	Description
1	Step Clock Input Anode (+): Internally connected to 5VDC.
2	Step Clock Input Cathode (-): Internally connected.
3	Direction Anode (+): Internally connected to 5VDC.
4	Direction Cathode (-): Internally Connected.
5	ON/OFF Anode (+): Internally connected to 5VDC.
6	ON/OFF Cathode (-): To enable function, simply use a contact closure to 0VDC to activate. This will de-energize the motor windings. An output may be necessary to activate.



# Dimensions

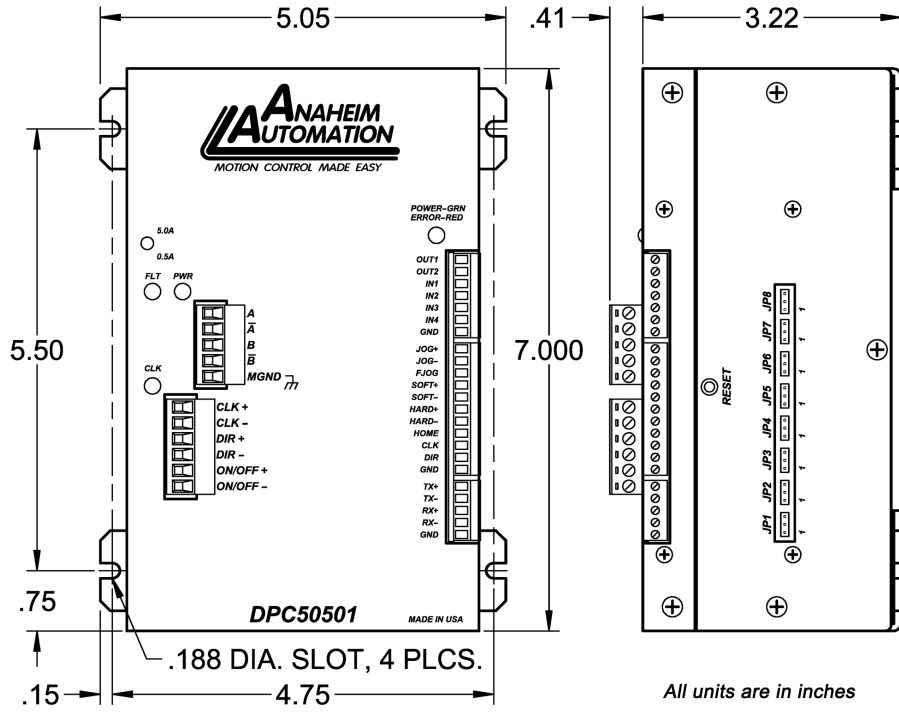

# Wiring Diagram

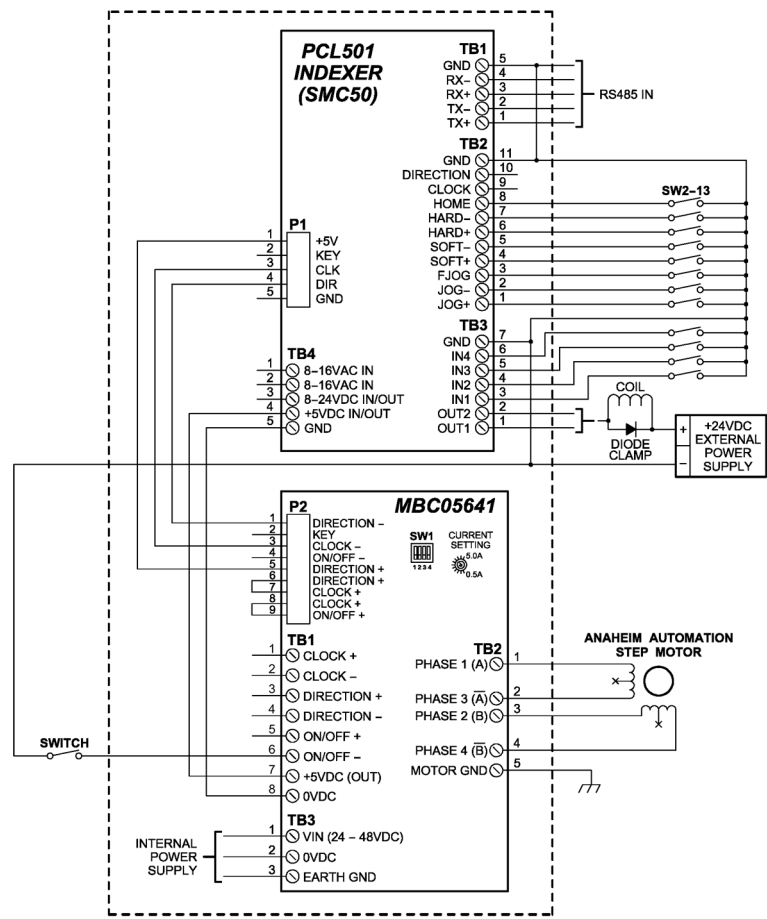

## Microstep Selection (SW1 Settings)

Switches 2, 3 and 4, of the DIP switch select the number of microsteps per step. The table below shows the standard resolution values along with the associated positions for the select switches. The standard waveforms are sinusoidal. Switch 1 selects the auto reduce current enable or disable. With Switch 1 On, reduce current is enabled, with Switch 1 Off, reduced current is disabled.

Resolution	Steps/Rev	Select 2	Select 3	Select 4
1	200	ON	ON	ON
2	400	ON	ON	OFF
5	1000	ON	OFF	ON
8	1600	ON	OFF	OFF
10	2000	OFF	ON	ON
16	3200	OFF	ON	OFF
32	6400	OFF	OFF	ON
64	12800	OFF	OFF	OFF

## Motor Selection

The DPC50501's bipolar microstep driver is compatible with both bipolar and unipolar motor configurations, (i.e. 8 and 4 lead motors, and 6 lead center tapped motors).

*Step motors with low current ratings and high inductance will perform better at low speeds, providing higher low-end torque. Motors with high current ratings and low inductance will perform better at higher speeds, providing more high-end torque.*

Since the DPC50501 is constant current source, it is not necessary to use a motor that is rated at the same voltage as the supply voltage. What is important is that the driver is set to the appropriate current level based on the motor being used.

***Anaheim Automation offers a comprehensive line of step motors in 17, 23, 34 and 42 frame sizes. Contact the factory to verify motor/drive compatibility.***

## Step Motor Selection Guide

Part Number	Unipolar Rating	Series Peak Rating	Parallel Peak Rating	Series Current Setting	Parallel Current Setting
23Y206	3.0A	3.0A	6.0A	60%	100%
23Y210	5.0A	5.0A	10.0A	100%	100%
23Y306	3.0A	3.0A	6.0A	60%	100%
23Y310	5.0A	5.0A	10.0A	100%	100%
34Y108	4.0A	4.0A	8.0A	80%	100%
34Y207	3.5A	3.5A	7.0A	70%	100%
34Y307	3.5A	3.5A	7.0A	70%	100%
23Y108	4.0A	4.0A	8.0A	80%	100%
23Y106	3.0A	3.0A	6.0A	60%	100%
23Y104	2.0A	2.0A	4.0A	40%	80%
17Y302	---	1.0A	---	22%	---
17Y202	---	1.0A	---	22%	---
17Y102	---	1.0A	---	22%	---

**Anaheim Automation offers motor cable, making hookups quickly and easy! Contact the factory or visit our website [www.anaheimautomation.com](http://www.anaheimautomation.com) for motor and cable offerings.**

### Setting the Output Current

The output current on the DPC50501 is set by an onboard potentiometer. This potentiometer determines the per phase peak output current of the driver. The relationship between the output current and the potentiometer value is as follows:

Peak Current	Potentiometer Setting	Peak Current	Potentiometer Setting
0.5A	0%	3.0A	60%
0.6A	10%	3.5A	70%
0.9A	20%	4.0A	80%
1.5A	30%	4.5A	90%
2.0A	40%	5.0A	100%
2.5A	50%	--	

### Reducing Output Current

Reducing the output current is accomplished by setting switch 1 of the DIP switch to the ON position and occurs approximately 20mSec after the last positive going edge of the step clock input. The amount of current per phase in the reduction mode is approximately 50% of the set current. When the current reduction circuit is activated, the current reduction resistor is paralleled with the current adjustment potentiometer. This lowers the total resistance value, and thus lowers the per phase output current.

### Determining Output Current

The output current for the motor used when microstepping is determined differently from that of a full/half step unipolar driver. In the DPC50501, a sine/cosine output function is used in rotating the motor. The output current for a given motor is determined by the motor's current rating and the wiring configuration of the motor. There is a current adjustment potentiometer used to set the output current of the DPC50501. This sets the peak output current of the sine/cosine waves. The specified motor current (which is the unipolar value) is multiplied by a factor of 1.0, 1.4, or 2.0 depending on the motor configuration (series, half-coil, or parallel).

## Step Motor Configurations

Step motors can be configured as 4, 6, or 8 leads. Each configuration requires different currents. Refer to the lead configurations and the procedures to determine their output current.

**WARNING:** Step Motors will run hot even when configured correctly. Damage may occur to the motor if a higher than specified current is used. Most specified motor currents are maximum values. Care should be taken to not exceed these ratings.

### 6 Lead Motors

When configuring a 6 lead motor in a **half-coil configuration** (connected from one end of the coil to the center tap), multiply the specified per Phase (or unipolar) current rating by 1.4 to determine the current setting potentiometer value. This configuration will provide more torque at higher speeds when compared to the series configuration.

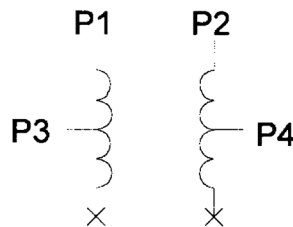

When configuring the motor in a **series configuration** (connected from end to end with the center tap floating) use the specified per phase (or unipolar) current rating to determine the current setting potentiometer value.

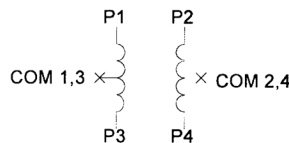

### 4 Lead Motors

Multiply the specified **series** motor current by 1.4 to determine the current adjustment potentiometer value. 4 lead motors are usually rated with their appropriate series current, as opposed to the *Phase Current*, which is the rating for 6 and 8 lead motors.

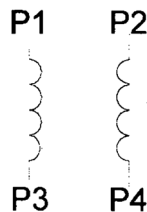

### 8 Lead Motors

**Series Connection:** When configuring the motor windings in series, use the per phase (or unipolar) current rating to determine the current setting potentiometer value.

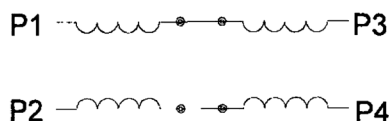

**Parallel Connection:** When configuring the motor windings in parallel, multiply the per phase (or unipolar) current rating by 2.0 to determine the current setting potentiometer value.

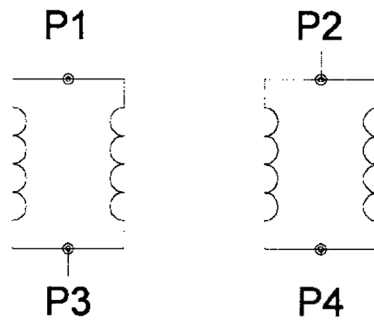

**Note:** After the current has been determined, according to the motor connections above, use Table 3 to choose the proper setting for the current setting potentiometer.

### Connecting the Step Motor

Phase 1 and Phase 3 of the step motor are connected to pins 1 and 2 on connector TB4. Phase 2 and Phase 4 of the step motor are connected to pins 3 and 4 on connector TB4. The motors case can be grounded to pin 5 on connector TB4.

**Note:** The physical direction of the motor with respect to the direction input will depend on the connection of the motor windings. To reverse the direction of the motor with respect to the direction input, switch the wires on Phase 1 and Phase 3.

**WARNING:** Do not connect or disconnect motor wires while power is applied!

### Short-Circuit, Mis-Wire, and Over Current Conditions

If it is found that there is a condition that causes on current in the driver phase transistors, the Red LED will turn on solid and power will be shut off the motor. To reset the drive turn power off, check wiring, and turn power back on.

## Section 2: Controller Functions

**Move Number of Steps:** The move number of steps command causes the motion to start in the direction last specified. This command will move the motor the number of steps given. (Range: 0 to 8388607)

**Move to Position:** The move to position command specifies the next absolute position to go to. The controller automatically sets the direction and number of steps needed to go to that position. (Range: -8388608 to +8388607)

**Home to Soft, Home Limit (2 Switch Operation):** This type requires two grounding type limit switches called home and soft. The first limit switch soft will decelerate the motor down to base speed. It will continue to run at base speed until it receives a home limit switch input causing the motor to stop. The home limit switch only activates after a soft limit is sensed. The soft limit is not bidirectional, meaning that it will work in only one direction as specified. The soft limit switch will work for any type of motion. The home limit switch will work only for home motions.

**Note:** Whenever a soft limit switch is activated, the motor will decelerate and run at base speed. Be sure to come back passed the soft limit switch to set any origins, otherwise the motor will decelerate as it goes passed the soft limit switch.

**Home to Home Limit:** This type homing differs in that only one limit switch is needed. The home limit switch in this case causes the motor to ramp down to base speed, reverse direction and continue until the limit switch is released. This is a good way to compensate for any backlash in the system. It is also useful for minimizing the number of limit switches needed for homing.

**Limit Switch Inputs:** The limit switch inputs are internally pulled up by a resistor making them normally +5 volts. To activate the input, the pin must be grounded to (0VDC) on the terminal block.

**Hard Limit Switches:** When a hard limit switch is encountered, the motion will stop. The position counter will also cease counting. Hard limits are intended as an emergency stop for your system. It should not be used to do any indexing type functions.

**Soft Limit Switches:** These switches are used exclusively when homing to a datum point. If positioned properly with the appropriate parameters, it causes the motor to ramp down to the base speed before encountering the home limit switch.

**Home Limit Switch:** This switch is used to establish the reference position designated “home” in home to home limit or home to soft, home limit.

**Set Position:** The set position command sets the position register to a designated value. The number will be the absolute position of the motor. The default value is 0. (Range: -8388608 to +8388607)

**Jog Inputs:** Jog is a manual function. The user can select the direction and speed (fast or slow) by grounding the appropriate combinations of inputs on a particular axis. These inputs are located on the terminal block. To jog a motor, it is necessary to ground the jog input on the axis for the direction desired. For fast jog, both the fast and jog command for the appropriate direction must be low at the same time. The closure of jog causes the motor to start at base speed and accelerate at a predetermined rate to jog speed. When the fast input is closed, the motor will then accelerate to a pre-programmed speed of 10kHz. The actual jog rates can be programmed. Fast jog is not programmable. The position register will keep track of the number of steps that are taken during jogging. Once a +jog or a -jog function has been performed, the direction register will retain the last direction of movement; that is, a subsequent go command will be in the same direction as the last jog command.

**Programmable Input and Outputs:** Four inputs and two outputs are provided per axis. The inputs may be used to initiate a machine cycle, for inter-axis coordination (in stored program mode), for operator intervention, for sensing a machine condition such as out of stock, or to wait for temperature to be reached. Outputs may be used to operate coolant valve, air cylinders, relays, or, with the right interfacing, any electronically controlled device. The inputs are TTL compatible. Since the inputs have pull up resistors, all that is required for a signal is a switch closure to ground (0VDC). With zero volts on the input, the pull up resistor source current is approximately 5mA. This will make the inputs read like they are logically reverse. A grounded input will read a "1" and an open input will read a "0". The outputs can drive all types of common peripheral power loads, including lamps, relays, solenoids, LED's, printer heads, and heaters. For inductive loads, it will be necessary to connect a clamping diode (refer to specification section). The outputs are current sinking, open drain FETs. They are capable of sinking up to 75mA per output with voltages up to 40VDC. Turning an output on will pull the pin to ground and turning an output off will make the pin open.

**Note:** For inductive loads, customers must connect a clamping diode in order to provide adequate fly-back protection. Input wiring should be kept separate from step motor wiring.

**Slew:** The slew command will accelerate the motor up to maximum speed and continue to run at the speed until reaching a hard limit switch, soft limit switches, or receiving a "." (stop hard) command.

**Finish Move:** When writing a program, the finish move command is used directly after a motion command. With this command, the controller will see a busy signal until the move is complete before executing any further commands. Unless the finish move command is used, the controller will keep on executing commands, even though the controller is not ready to use it. This data will be ignored by the controller, so the program will not work as expected.

**Run:** The run command starts the execution of a stored program.

**Quit:** The quit command is used within a stored program and stops the execution of the program. This command must be used at the end of all programs.

**Wait:** In stored program mode, the wait command pauses the program for the specified number of milliseconds. (Range:1 to 9999)

**Verify:** The verify command causes the controller to send data back to the PC or PLC. The data is sent as an ASCII decimal string followed by a carriage return and a line feed. The permissible verify commands are shown below.

Command	Description
A	Verify Acceleration/Deceleration
B	Verify Base Speed
F	Verify if Controller is Busy
J	Verify Jog Speed
M	Verify Max Speed
N	Verify Number of Steps
O	Verify Outputs
P	Verify Goto Position
Z	Verify Position
+	Verify Direction (1 is CW, 0 is CCW)

**Loop:** The Loop instruction allows the user to loop a program a variable number of times. The program will loop to the designated address location of the program. The address must always be a lower address value than the instruction itself. No nested loops are allowed.

**Accelerated/Deceleration:** The acceleration and deceleration are by default the same value. This function controls the time that the motor will take to move from base speed to max speed. The higher the value, the slower the motor will accelerate. The same principal applies for the deceleration which is controlling the time it takes to go from maximum speed to base speed. The higher the value, the slower the motor will decelerate. (Range:1 to 255)

**Base Speed:** The base speed is the speed at which motion starts and stops. It is entered directly as the number of steps per second. This speed must always be less than the max speed. (Range: 77 to 3500)

**Max Speed:** The max speed is the top speed the user wants the motor to run at. This speed must always be greater than the base speed. It is entered directly as the number of steps/second. (Range: 77 to 15000)

**Jog Speed:** The jog speed sets the slow jog rate. Jog (+/-) can also be used in conjunction with the FJOG pin. The FJOG pin, when grounded, will ramp the motor to 10kHz. This speed must always be greater than the base speed.



## Section 3: SMC50WIN Software

The SMC50WIN software is a handy utility that supports Anaheim Automation's line of PCL501 and PCL511 step motor controllers. Connecting your PC to the controller, via a serial cable, the SMC-50WIN software can easily perform the following tasks:

- Exercise and monitor the controller
- Write and edit stored programs for stand-alone operation
- Directly communicate with the controller

### Installation

#### Software

- The SMC50WIN is supplied on a CD, containing the setup program and the SMC50WIN software.
- SMC50WIN software is compatible with all versions of Windows including Windows 2000, Windows XP, Vista, and Windows 7.

#### Windows 95/98/NT/ME/2000/XP Installation

##### Option 1

1. Insert the CD into the drive
2. From the Program Manager select **Start | Run**
3. Enter **D:\setup** and click **OK** - use the appropriate drive letter (i.e. **D** or **E**)

##### Option 2

1. Open Windows Explorer
2. Open CD Drive Folder (D: or E:)
3. Double Click the setup Icon

### Getting Started

1. Double click on the SMC50WIN icon to run the SMC50WIN software.
2. Apply power to the controller unit.
3. Set the appropriate communication setting by selecting Setup | Com Port Settings from the menu bar. (Ctrl+M is a shortcut)
4. Establish communications with the controller by clicking on the Connect Icon, or select Setup | Connect from the menu bar. If the unit is connected properly, the program will notify you when communication has been established. (Ctrl+C is a shortcut)

## “The Unit is Connected” / “The Unit is Not Connected”

On the right of the Toolbar, the user will find the communication status of the controller. If communication is not established, please refer to the troubleshooting section.

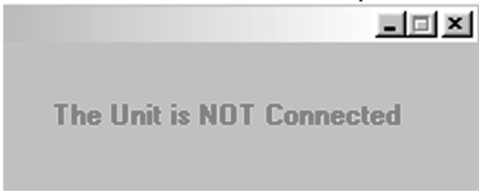

## File Menu

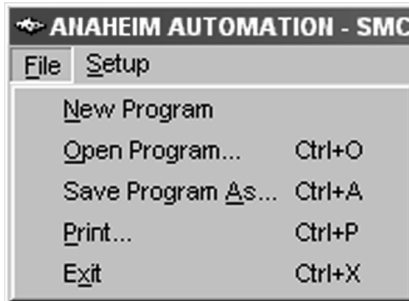

New Program	Start editing a new program.
Open Program	Open an existing program from disk.
Save Program As	Save the current program to disk.
Print...	Print the current program.
Exit	Exit the SMC50WIN software.

## Setup Menu

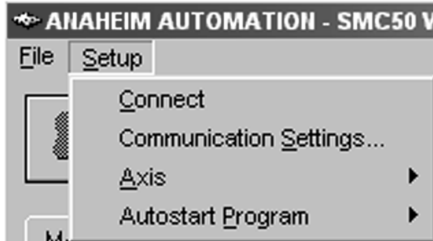

Connect	Establish communications with the controller.
Communication Settings...	COM port & baud rate settings.
Axis	Select axis (0-31) for multi drop units.
Autostart Program	Enable/Disable program execution on power up.

## Toolbar

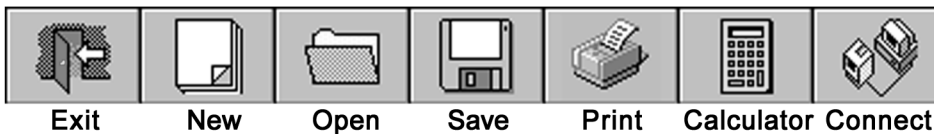

Exit	Exit the SMC50WIN software.
New	Start a new program.
Open	Open an existing program.
Save	Save the current program.
Print	Print the current program.
Calculator	Open the desktop calculator.
Connect	Establish communication with the controller.

## Tab Sheets



Motion	Controls and executes motion on the controller.
Program	Write and modify PCL501 stored programs.

## Motion Tab Sheet

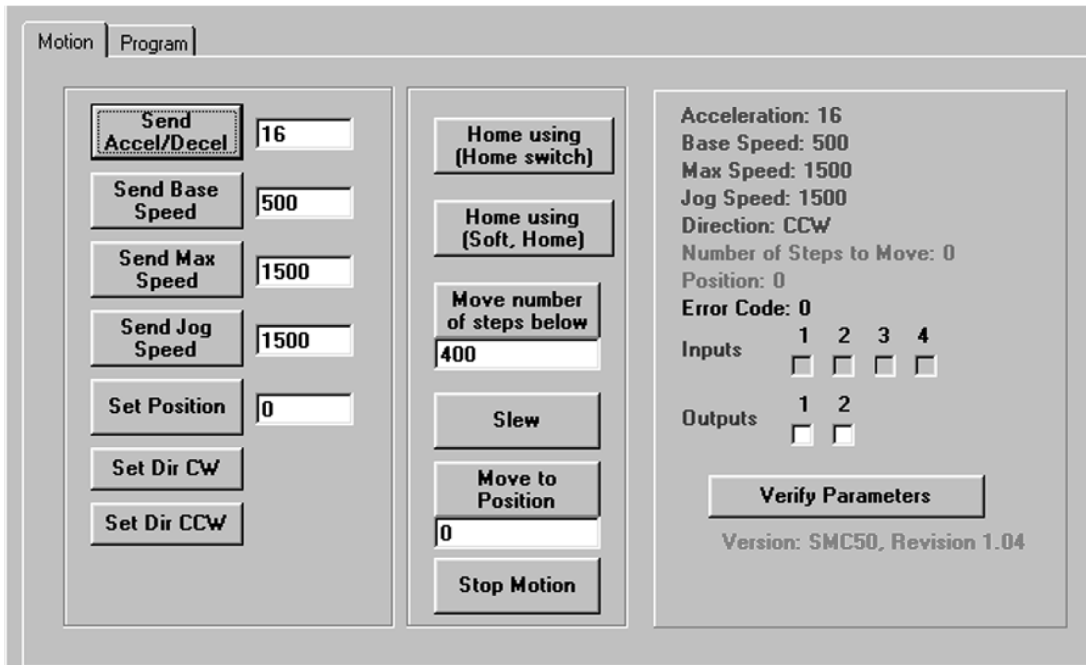

Set Accel/Decel	Send acceleration & deceleration parameter to controller. (step/sec <sup>2</sup> )
Set Base Speed	Send base speed parameter to the controller. (step/sec)
Set Max Speed	Send maximum speed parameter to the controller. (step/sec)
Set Jog Speed	Send jog speed parameter to the controller. (step/sec)
Set Position	Set motor position.
Set Direction CW	Set direction to clockwise.
Set Direction CCW	Set direction to counter-clockwise.
Home using (Home Switch)	Motor will seek the home position by moving towards home switch. (One switch is required to stop anti-backlash)
Home using (Soft and Home Switches)	Motor will seek the home position by moving towards home switch but motor will slow down to base speed when the soft switch is triggered, following by triggering the home switch to stop motion. (Two switches are required to stop)
Move number of steps below	Motor will move number of steps entered.
Move to Position	Motor will move to specified position.
Slew	Motor will ramp up to maximum speed and keep moving until stop motion is triggered.
Stop Motion	Stop any motor motion.
Inputs	View Inputs. (checked = On, blank = Off)
Outputs	View and trigger outputs. (checked = ON, blank = OFF)
Verify Parameters	Updates and displays controllers parameters sheet and resets the error codes.

## Motion Tab Sheet Tutorial

This tutorial will demonstrate the motion tab sheet:

1. Start the SMC50WIN software and power up the controller.
2. Click the connect icon and establish communications with the controller.
3. With the motion tab sheet displayed.
4. Enter 400 for the “Move number of steps below” button.
5. Click the “Move number of steps below” button, the motor should move 400 steps - 1 revolution on a 200 steps/rev motor running in half step mode.

## Program Tab Sheet

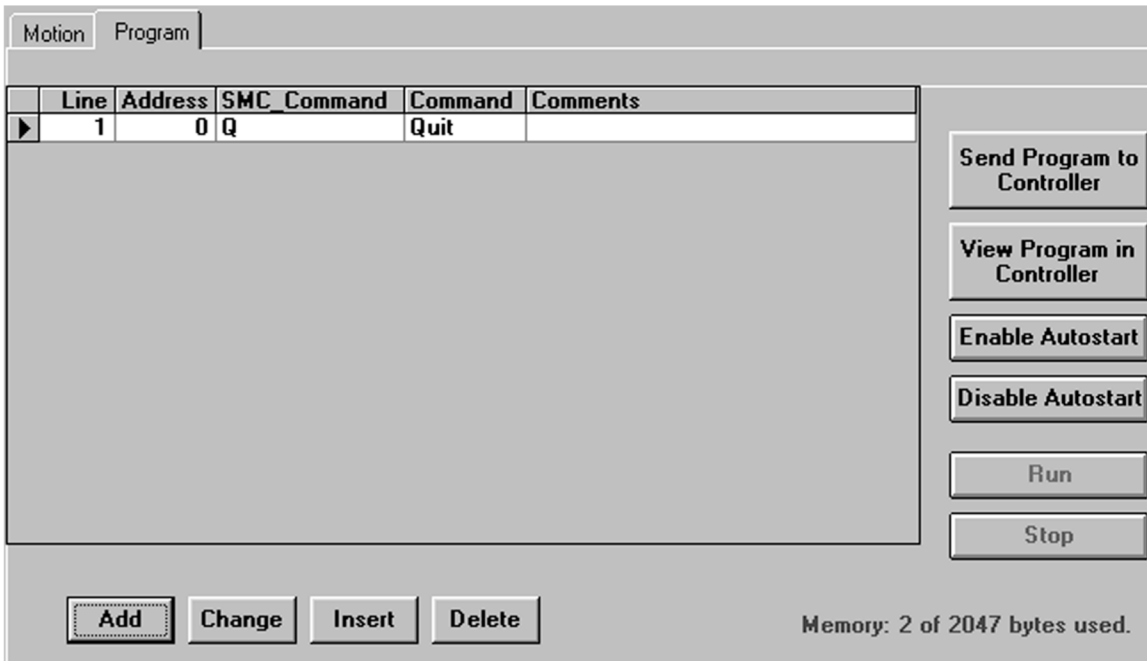

Send Program to Controller	Send current program to the controller.
View Program in Controller	View program in the controller memory.
Enable Autostart	Program will start when controller is powered up.
Disable Autostart	Program will only execute when run is clicked.
Run	Execute the program in the controller memory.
Stop	Abort program execution.
Add	Adds a new line of code to the end of the program.
Change	Edits the currently selected line of code.
Insert	Insert a new line of code before the currently selected line of code.
Delete	Deletes the currently selected line of code.

## Current Program Filename

With the program tab sheet selected the user can obtain the current program filename, located in the lower left corner of the SMC50WIN window. All programs created by the SMC50WIN software will have a .mdb extension.



## SMC50 Memory Available

With the program tab sheet selected the user can obtain the amount of available memory, located in the lower right corner of the SMC50WIN window. The controller has a maximum available memory of 2047 bytes - each instruction can use from 1 to 5 bytes.



## Currently Selected Line

The currently selected line is indicated in the program by the right pointing arrow/triangle in the left column.

Line	Command	Comments
2	Max Speed=2500	
3	Accel/Decel=25	
4	Jog Speed=700	Set jog speed
5	Direction CCW	
6	Home0	Go to home
7	Position Register=0	
8	Max Speed=5000	
9	If Inputs=1 Then goto address 10	
10	Direction CW	
11	Go Absolute 400	
12	Wait 50	
13	Set Outputs 1-on 2-off	
14	Go relative 10000	
15	Finish Move	

Clicking on any line will select a new currently selected line.

## Add/Change/Insert Commands

Add command contains 2 different tab sheets, which are Motion Parameters and Program Parameters.



Motion Parameters	Software section that allows user to enter speeds, positions, direction, etc.
Program Parameters	Software section that allows user to manipulate looping routines, I/O, delays, etc.

## Motion Command Tab Sheet

The screenshot shows a dialog box titled "Add Command" with two tabs: "Motion Parameters" and "Program Parameters". The "Motion Parameters" tab is active. It contains several radio button options and text input fields:

- Accel/Decel [text input]
- Base Speed [text input]
- Max. Speed [text input]
- Direction CW
- Direction CCW
- Set Position [text input]
- Finish Move
- Move [text input] Steps
- Move to Position [text input]
- Repeat Last Move
- Home to Soft, Home Limits
- Home to Home Limit
- Slew (move continuously)
- Stop Motion

Below the options is a "Comment:" label followed by a text input field. At the bottom of the dialog, there is a status bar with the text "Please choose a command." and two buttons: "Cancel" and "OK".

The motion command tab sheet controls the motion information of the motor such as Maximum Speed, Base Speed, Go Absolute, and etc.

- It works similar to the **Motion Tab Sheet** explained above in the Getting Started section.
- To add a line of motion control, select appropriate motion control from the list, then enter the required value for that particular action. Then, click **OK**.
- Comment is optional, for any lines of code.
- The text box above the **OK** and **Cancel** buttons will display useful information about each command.

Accel/Decel	Set program acceleration and deceleration parameter. (step/sec <sup>2</sup> )
Base Speed	Set program base (start) speed rate. (step/sec)
Max. Speed	Set program maximum (running) speed rate. (step/sec)
Set Position	Set motor position.
Move____Steps	Relative move command will allow motor to move the defined number of steps entered.
Move to Position	Absolute move command will move motor to the position specified.
Slew (Move Continuously)	Command will initiate motion in the direction specified until a limit switch or hard stop is triggered.
Repeat Last Move	Command will repeat the previous motion command.
Home to Soft, Home Limits	Command will initiate motion in the direction last entered seeking the soft input first to slow the motor down to base speed, then to stop when the home limit is triggered.
Home to Home Limit	Command will initiate motion in the direction last entered seeking the home limit which will stop the motor, reverse the motor direction and stop when the home limit switch is no longer triggered.
Finish Move	Command will allow any motion command to be completed before continuing. This command must be entered after every motion command.
Stop Motion	Command will stop all motion of the motor.
Direction CCW	Sets motor direction for counter-clockwise movement.
Direction CW	Sets motor direction for clockwise movement.
Comment:	Comments are always useful instructions or debugging methods to help keep the user informed as to what the program is executing at the specific line.

# Program Parameters

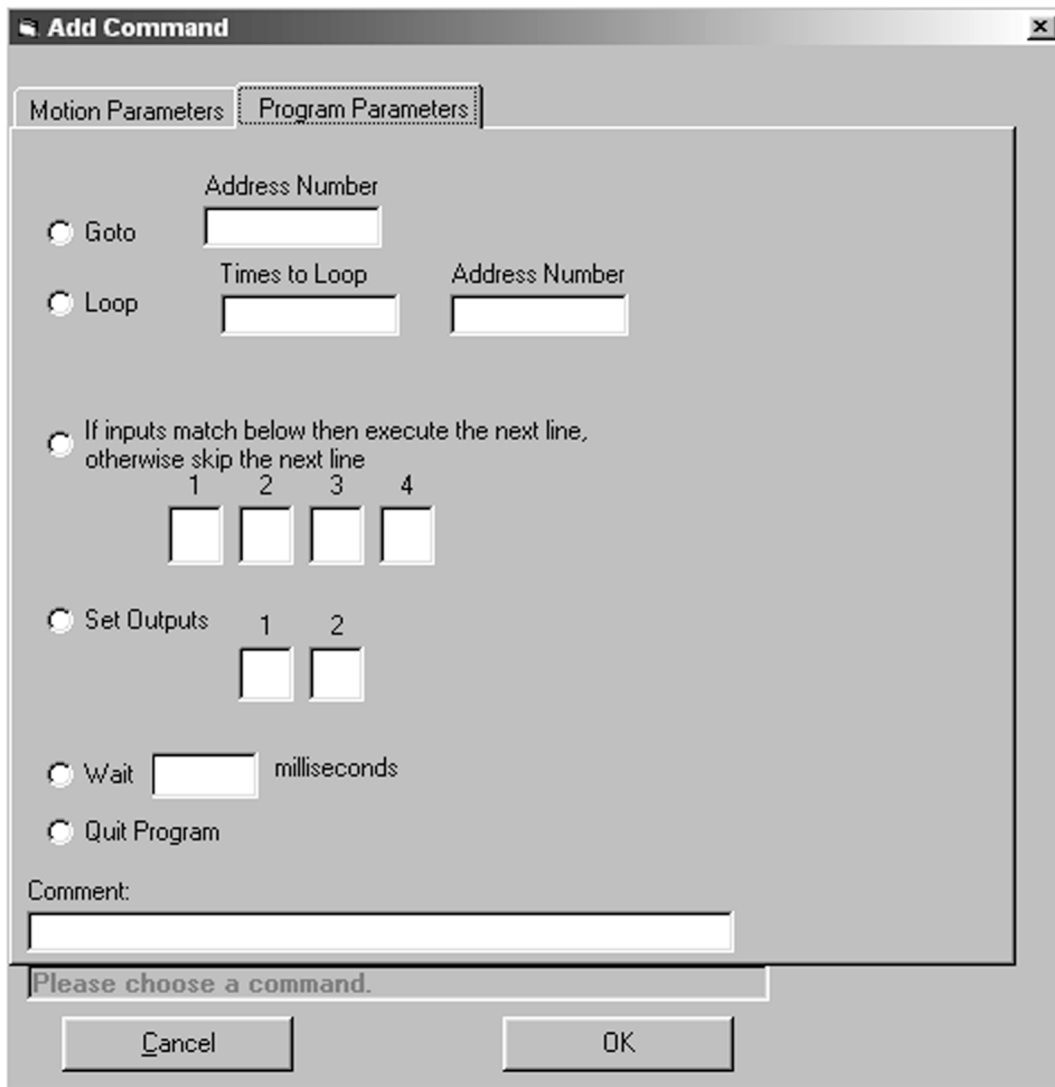

Goto	The Goto command allows program to jump to specified address.
Loop	Loop allows a sequence of commands to be looped a specific number of times to an address, which is lower in value. No nested loops are allowed.
If inputs match below then execute next line, otherwise skip next line	This conditional command allows the user to go to a specified address in the program if the inputs triggered match the selected or checked input box. If the inputs (1 through 4) do not match the next line is skipped.
Set Outputs	The outputs can be turned (on=1) or (off=0). These outputs can be used to trigger PLC operations, relays, solenoids, etc.
Wait ____milliseconds	This command allows the user to enter a delay in milliseconds. This wait command is useful for pausing the program from reading the next command.
Quit Program	The quit command is a required function used only at the end of the program.
Comment:	Comments are always useful instructions or debugging methods to help keep the user informed as to what the program is executing at the specific line.



# Calculator

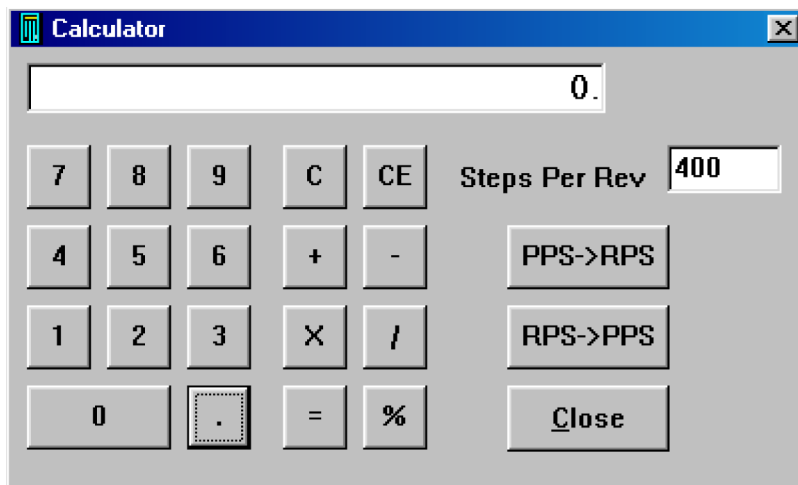

PPS -> RPS	Convert from pulses per second to revolution per second.
RPS ->PPS	Convert from revolution per second to pulses per second.
Steps Per Rev	Enter the number of steps per revolution of the step motor. The default is for a 200 step/rev motor in half step, which is equal to 400.
Close	Exit Calculator.

## Section 4: Direct Talk Mode

Direct mode is used to directly control the motion for real time movements through serial communication. The PCL501 has 20 commands which are easy to remember for direct movement of a step motor.

### COM Port Settings

**Baud Rate:** Select one from the Baud Rate Selection chart in section 1.

**Parity:** None

**Data Bits:** 8

**Stop Bits:** 1

**Flow Control:** Xon/Xoff

### Unit Selection

In order to select a unit the @ command followed by 0 (address of the unit) must be sent.

NOTE: There should be no spaces between the @ and address select.

### How to select the unit:

@0 (Unit is selected)

@1 (Unit is selected)

@29 (Unit 29 is selected)

### How to get a response from the unit:

@0\$ (Carriage Return)

After the \$ command, the controller will return a SMC50 + the current revision number.

Note: In direct talk mode each command is followed by a carriage return.

The unit communicates in half duplex mode, therefore proper setup of hyper terminal is necessary to view characters, if characters are to be echoed back to the screen.

### Instructions

All instructions require that no spaces be sent between the command and the parameter followed by a carriage return.

@0 not @ 0

### Command Summary:

A - Acceleration/Deceleration

B - Base Speed

G - Go Number of Steps

H - Home

I - Read Inputs

J - Jog Speed

L0 - Get Limits Status

LS - Soft Limit Input Bit

M - Max Speed

N - Number of Steps

O - Set Outputs

P - Absolute Position

S - Go Slew

V - Verify

Z - Position

. - Stop Motion

+ - Clockwise Direction

-- Counterclockwise Direction

\$ - Versions Number Register

! - Error Codes Register

## **\$ - Version Number Register**

Format:        \$

Description:   This command requests the controller to return the version number.

## **! - Error Codes Register**

Format:        !

Description:   This command requests the controller to get the current error code and print it to the screen.

## **A - Acceleration/Deceleration**

Format:        A[value]

Description:   This command sets the acceleration profile which can be an integer value between 1 and 255. The lower the value the faster the motor acceleration, so a 1 is the fastest profile and 255 is the slowest.

Range:         1 - 255

## **B - Base Speed**

Format:        B[value]

Description:   This command sets the base (start) speed for motion. This value must be set before motion begins and be less than the maximum speed.

Range:         77 - 3500

## **M - Max Speed**

Format:        M[value]

Description:   This command sets the maximum (running speed for motion. This value must be set before motion begins and be greater than the base speed.

Range:         77 - 15000

## **J - Jog Speed**

Format: J [value]

Description: This command sets the jog speed. This value must be greater than the base speed.

Range: 77 - 15000

## **N - Number of Steps**

Format: N [value]

Description: This command sets the number of clocks for the controller to send out following a G command.

Range: 0 - 8388607

## **G - Go Number of Steps**

Format: G

Description: This command is used to send a set number of clocks out of the controller. An N or P command must be entered before the G command.

## **P - Absolute Position**

Format: P[value]

Description: This command calculates and sets the number of steps necessary to move to the specified position. ( $N=P-Z$ )

Range: -8388608 - 8388607

## **S - Go Slew**

Format: S

Description: This command will send clocks out to the controller. The only commands that can stop the clocks are; . (stop motion) or LS (soft limit). Motion can also be stopped by using the limit switch inputs. The ramp profile is specified by the B (base speed), M (max speed), and A (acceleration/deceleration) commands.

## **Z - Position**

Format: Z[number]

Description: This command sets the current position as a reference. This register can contain a positive or negative value but cannot be changed while motion is in progress.

Range: -8388608 to +8388607

## **H - Home**

Format: H [binary]

Description: This command sends clocks out of the controller until the home limit or the soft limit is active. There are two types of homing available.

Home Types: H0: In type 0 homing, the controller will send clocks until a soft limit is reached, then ramp down to base speed. Clocks will continue until a home or hard limit is reached.

H1: In type 1 homing, the unit will move until a home limit is reached, then change directions, ramp down to base speed and stop upon release of the home limit input.

## **. - Stop Motion**

Format: .

Description: This command will stop all motion. It can also be used to stop the current program that is running.

## **+ - Clockwise**

Format: +

Description: This command sets the direction output to clockwise.

## **- - Counter Clockwise**

Format: -

Description: This command sets the direction output to counterclockwise.

## **V - Verify**

Format: V[command]

Description: This command can be used with most commands to verify the register contents. This is a read only command. Valid Commands are: A, B, F, J, M, N, O, P, Z, and +.

## **O - Sets Outputs**

Format: O [value]

Description: This command sets the outputs according to the binary value. Output 1 is the LSB and output 2 is the MSB.

Range: 0 - 3

## **I - Read Inputs**

Format: I

Description: This command returns the binary value of the inputs to the PC. Since the inputs are pulled up internally, they will return a high when they are pulled low. For example, if all inputs are active (grounded), the command will return a 15. If all inputs are inactive (open), the command will return a 0. Input 1 is the LSB, input 2 is the second bit, input 3 is the third bit, and input 4 is the MSB.

## **L0 - Get Limit Status**

Format: L0

Description: This command returns the binary value of the hard and soft in a binary format. The soft limit is the LSB and the hard limit is the MSB.

## **LS - Soft Limit Input Bit**

Format: LS

Description: This command will ramp the clocks down to base speed. The move type then determines what will happen. In a relative or absolute type motion the controller will continue to the set position and stop. In a slew type motion the controller will ramp down and stop.

## Section 5: Troubleshooting

### Troubleshooting

**Problem:**

*Can not establish communications with the controller.*

**Possible Solutions:**

1. Make sure the controller has power. Is the controller's Green LED on?
2. Check RS485 connections.
3. Check for loose cable connection either on the controller or COM Port.
4. Was the software installed successfully?
5. Go to **Setup | Communication Settings** and verify COM Port and baud rate settings.
6. Physically verify that the axis address matches with the controller unit selected address.
7. Go to **Setup | Axis** and verify address settings are the same.
8. Click on **Connect** icon to communicate with the controller.
9. If problems still exist, contact Anaheim Automation Tech Support.

Anaheim Automation, Inc. Tech Support:	4985 E Landon Drive Anaheim, CA, 92807 Phone: (714) 992-6990 Fax: (714) 992-0471 <a href="http://www.anaheimautomation.com">www.anaheimautomation.com</a>
---	---

**Problem:**

*There is no power to the controller.*

**Possible Solutions:**

1. Is the driver connected to the appropriate power supply?
2. Check the driver pack's fuse.
3. If problems still exist, contact Anaheim Automation, Inc. Tech Support.

**Problem:**

*My program won't "Autostart".*

**Possible Solutions:**

1. Verify that the Autostart Function has been enabled.
2. Go to **Setup | Autostart Program** and Click on **Enable**.
3. If problems still exist, contact Anaheim Automation Tech Support.

**Problem:**

*The Controller has a fault condition.*

**Possible Solutions:**

1. Verify your program for improper syntax that may cause an error code.
2. Physically press the reset button on the controller to clear an error.
3. Another way to clear an error is by using either the SMC50WIN software or the direct mode command instructions set.
4. The SMC50WIN can clear an error in the real time motion tab section by clicking on the verify parameters button.
5. The direct mode commands can clear an error by simply prompting the error codes register.

Example: @0! (carriage return)

Description: Select the unit address by typing @ followed by the address number and ! (Error Codes Register) and a carriage return.

Note: Read the Error returned to the screen to better understand what can be causing the fault condition. The error is return in binary coded decimal format. If two errors were received, their binary values would be added together.

**Error Codes**

Error Code	Type	Description
1	Receive Overflow Error	The serial communications had a receiving error. This is an internal error caused by the computer.
4	Command Error	A bad command was sent to the controller. Please check to see that the command being sent is valid.
16	Motor Error	Motor speed profiles are set incorrectly. Please make sure that the base speed is less than the max speed and that the speeds are within their valid ranges.
64	Range Overflow Error	There was an invalid number of commands and characters sent to the controller. Check to see if the parameters are invalid for the command that was sent.
128	Transmit Error	To many parameters sent back to the PC. This is an internal error caused by the EEPROM.
256	Mode Error	Controller is in a wrong mode. Some commands are good only in programming mode, while others are good only in direct mode. Check the direct mode section to see which commands are good in direct mode.
512	Zero Parameters Error	There were no parameters sent to the controller. A command was sent to the controller that expected to see parameters after the command.
2048	Memory Range Error	The specified address is out of range. This is caused by overflowing the program memory by having a program that is to large.
4096	Memory Command Error	The command pulled from memory is invalid. The command that was stored into the EEPROM was non-executable by the program. This is an internal error.
8192	Busy Error	The controller is sending out clocks to the driver and can not execute the next instruction.



## Section 6: Sample Programs

### Sample Program 1:

Sample Program 1 illustrates a typical application where a system moves to a specific position required. The sample program shows how to use motion and goto instruction commands.

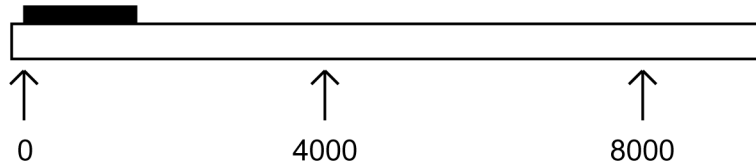

	Line	Address	Command	Comments
	1	0	Accel/Decel=5	
	2	3	Base Speed=100	
	3	7	Max Speed=1000	
	4	11	Position Register=0	
	5	16	Direction CW	
	6	19	Go relative 4000	Move to 1st Position
	7	24	Finish Move	
	8	26	Repeat Last Move	Move to 2nd Position
	9	28	Finish Move	
	10	30	Go Absolute 0	Return to Zero Position
	11	35	Finish Move	
	12	37	Goto Address 0	Goto Top of Program & Repeat
▶	13	41	Quit	

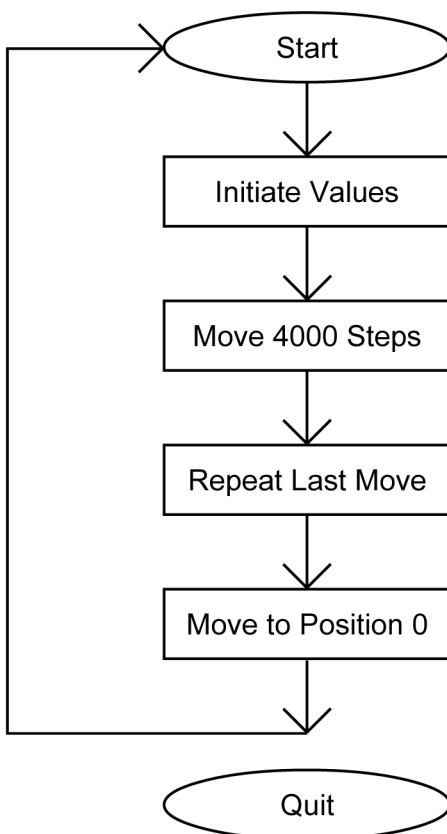

## Sample Program 2:

Sample Program 2 illustrates a typical application where a system is first sent home to a datum or 0 position. This sample program shows how a motor will move to 3 different positions utilizing some of the motion commands and loop routine.

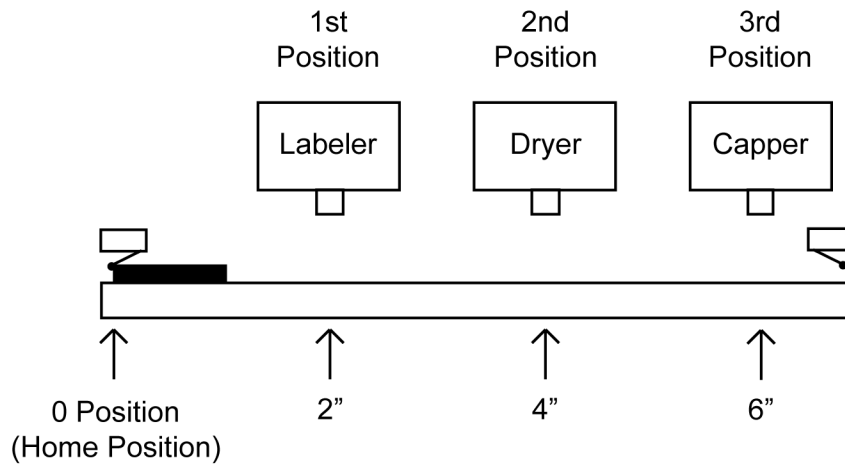

Line	Address	Command	Comments
1	0	Accel/Decel=5	Initialize Parameters
2	3	Base Speed=100	
3	7	Max Speed=1000	
4	11	Direction CCW	
5	13	Home to Home Limit Switch (Type1)	Home to a Physical Switch
6	16	Finish Move	Pause until move is finished
7	18	Position Register=0	Initialize Position Register
8	23	Direction CW	Set Direction
9	25	Go relative 4000	Move to 1st Position
10	32	Finish Move	
11	34	Repeat Last Move	Move to 2nd Position
12	36	Finish Move	
13	38	Wait 1000	Delay 1 sec or 1000msec
14	42	Repeat Last Move	Move to 3rd Position
15	44	Finish Move	
16	46	Loop 3 Times to Address 0	Loop to Top of Program 3 times
17	51	Quit	Program Quits after 4 cycles

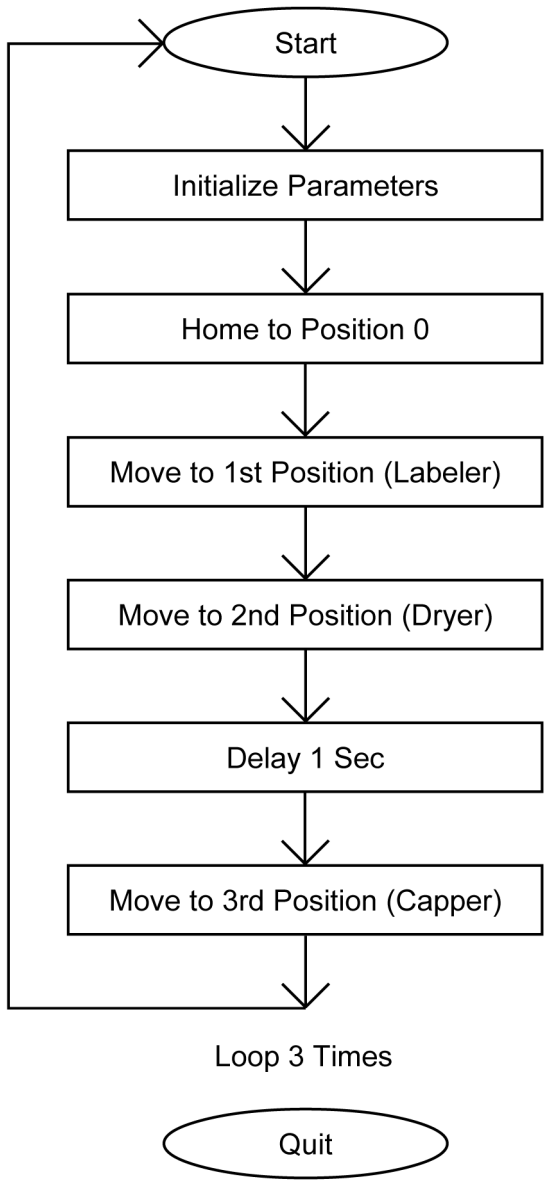

## Appendix 1: ASCII Table for Direct Mode

ASCII Symbol	Hex Value	ASCII Symbol	Hex Value
Carriage Return	0D	I	49
0	30	J	4A
1	31	L0	4C 30
2	32	LS	4C 53
3	33	M	4D
4	34	N	4E
5	35	O	4F
6	36	P	50
7	37	S	53
8	38	V	56
9	39	Z	5A
A	41	!	21
B	42	\$	24
F	43	+	2B
G	44	-	2D
H	45	.	2E

## **COPYRIGHT**

Copyright 2012 by Anaheim Automation. All rights reserved. No part of this publication may be reproduced, transmitted, transcribed, stored in a retrieval system, or translated into any language, in any form or by any means, electronic, mechanical, magnetic, optical, chemical, manual, or otherwise, without the prior written permission of Anaheim Automation, 4985 E Landon Drive, Anaheim, CA 92807.

## **DISCLAIMER**

Though every effort has been made to supply complete and accurate information in this manual, the contents are subject to change without notice or obligation to inform the buyer. **In no event will Anaheim Automation be liable for direct, indirect, special, incidental, or consequential damages arising out of the use or inability to use the product or documentation.**

Anaheim Automation's general policy does not recommend the use of its' products in life support applications wherein a failure or malfunction of the product may directly threaten life or injury. Per Anaheim Automation's Terms and Conditions, the user of Anaheim Automation products in life support applications assumes all risks of such use and indemnifies Anaheim Automation against all damages.

## **LIMITED WARRANTY**

All Anaheim Automation products are warranted against defects in workmanship, materials and construction, when used under Normal Operating Conditions and when used in accordance with specifications. This warranty shall be in effect for a period of twelve months from the date of purchase or eighteen months from the date of manufacture, whichever comes first. **Warranty provisions may be voided if products are subjected to physical modifications, damage, abuse, or misuse.**

Anaheim Automation will repair or replace at its' option, any product which has been found to be defective and is within the warranty period, provided that the item is shipped freight prepaid, with previous authorization (RMA#) to Anaheim Automation's plant in Anaheim, California.

## **TECHNICAL SUPPORT**

If you should require technical support or if you have problems using any of the equipment covered by this manual, please read the manual completely to see if it will answer the questions you have. If you need assistance beyond what this manual can provide, contact your Local Distributor where you purchased the unit, or contact the factory direct.

**ANAHEIM AUTOMATION**