

17Y9 Series - High Torque Stepper Motors

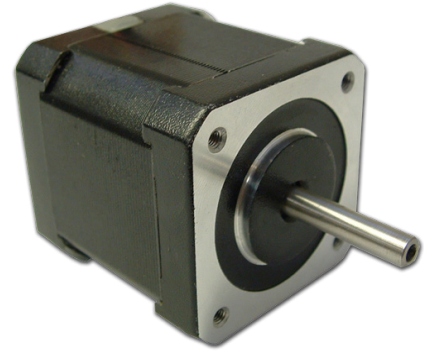

FEATURES

- **NEMA 17 Frame Size**
- **0.9° Step Angle**
- **IP50 Rated**
- **High Torque - Up To 86 oz-in**
- **High Step Accuracy and Resolution**
- **Shaft Flat as Standard**
- **Can be Customized for**
 - **Winding Current**
 - **Shaft Options**
 - **Cables and Connectors**
- **CE Certified and RoHS Compliant**



DESCRIPTION

The 17Y9 Series High Torque Stepper Motors offer a great value without sacrificing quality. These motors have a 0.9° step angle making them higher precision than the typical 1.8° version. However, like the standard versions, motors were designed to offer the highest possible torque while minimizing vibration and audible noise. A broad line of motor windings and stack lengths are available off-the-shelf. We have both 4-Lead and 6-Lead motors that can be connected in series or unipolar to allow the maximum flexibility for your application. We can also customize the winding to perfectly match voltage, current, and maximum operating speed to meet your requirements.

See [Accessories](#) on our website for optional motor adders such as encoders, cables, and connectors. Gearbox options can be found in [Gearboxes](#). See compatible drivers for the 17Y9 Series: [MBC15081](#) and [MBC25081TB](#).

SPECIFICATIONS

Model #	NEMA Size	Bipolar Torque (oz-in)	Series Current (A)	Bipolar Voltage (V)	Series Inductance (mH)	Series Resistance (ohm)	Rotor Inertia (oz-in-sec ²)	Shaft Diameter (in)	# of Terminals	Weight (lbs)	"L" Length (in)
17Y9100.5S-LW6	17	31	0.22	17	132	77	0.0005	0.197	6	0.5	1.3
17Y9101S-LW6	17	31	0.42	9	38	20	0.0005	0.197	6	0.5	1.3
17Y9102S-LW6	17	31	0.67	6	16	8	0.0005	0.197	6	0.5	1.3
17Y9104S-LW4	17	31	1.33	3	4	2	0.0005	0.197	4	0.5	1.3
17Y9101D-LW4	17	51	0.28	14	96	51	0.0005	0.177	4	0.5	1.3
17Y9200.8S-LW6	17	50	0.28	17	120	60	0.0008	0.197	6	0.6	1.6
17Y9201S-LW6	17	50	0.57	9	27	15	0.0008	0.197	6	0.6	1.6
17Y9202S-LW6	17	50	0.85	6	14	7	0.0008	0.197	6	0.6	1.6
17Y9204S-LW4	17	50	1.4	4	6	3	0.0008	0.197	4	0.6	1.6
17Y9301S-LW6	17	61	0.4	17	180	71	0.0010	0.197	6	0.8	1.9
17Y9301.6S-LW6	17	61	0.57	9	40	15	0.0010	0.197	6	0.8	1.9
17Y9302S-LW6	17	61	0.70	6	30	9	0.0010	0.197	6	0.8	1.9
17Y9304S-LW4	17	61	1.68	3	5	2	0.0010	0.197	4	0.8	1.9

Notes: The 8th character "S" denotes single shaft, use "D" for double shaft. Custom leadwires, cables, connectors, and windings are available upon request.

L010379

DIMENSIONS

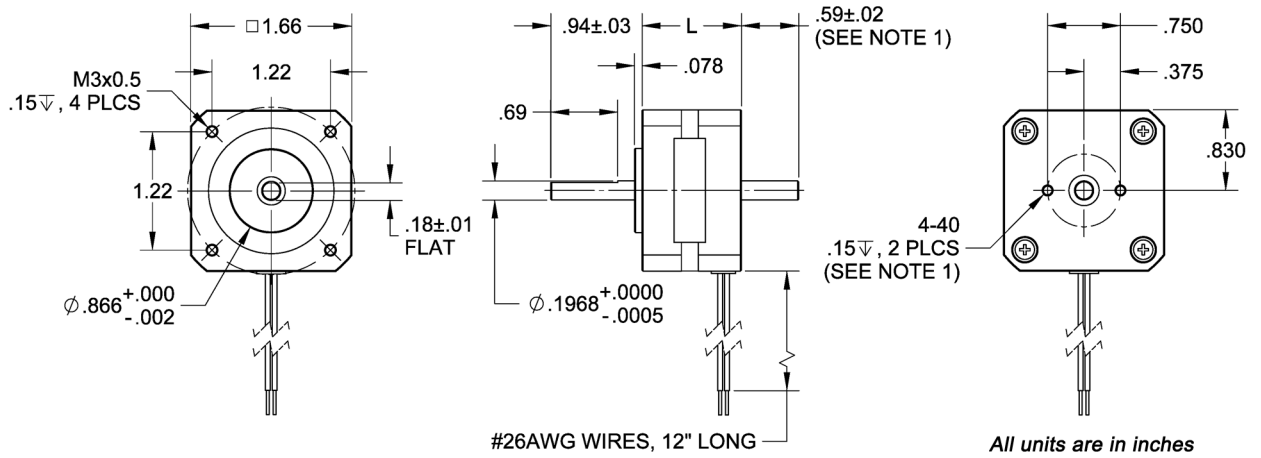

Note1: Applies to dual shaft option only

WIRING INFORMATION

SPECIFICATION CONVERSION TABLE

Connection	Current (A)	Resistance (R)	Inductance (L)
Series Standard	A	R	L
Parallel	2A	R / 4	L / 4
Unipolar	1.414A	R / 2	L / 4

Connection	Lead Wire Connection	Lead Wire Color
4 - Lead Bipolar Series MBC Series	Phase 1 (A)	Black
	Phase 3 (/A)	Orange
	Phase 2 (B)	Red
	Phase 4 (/B)	Yellow
6 - Lead Unipolar BLD, TM Series	Phase 1	Red
	Phase 3	Red/White
	Phase 2	Green
	Phase 4	Green/White
	Common Phase 1 & 3	Black
	Common Phase 2 & 4	White

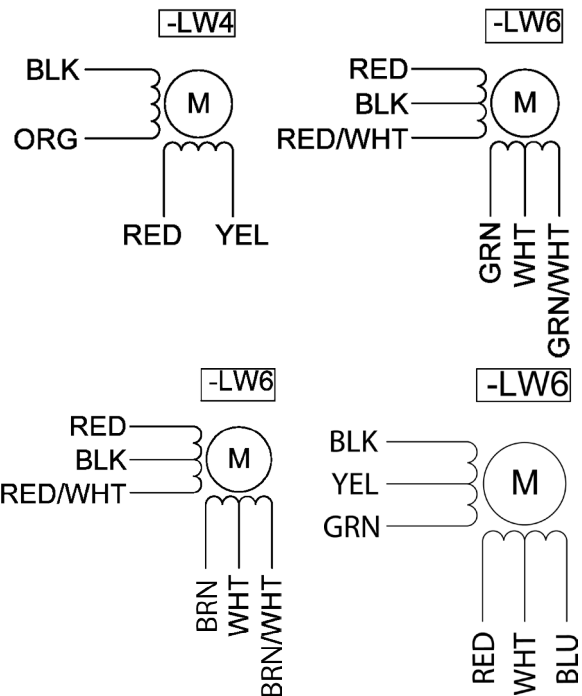

SPECIFICATIONS

Step Angle Accuracy:	±5% (Full Step, No Load)	Insulation Resistance:	100M Ohm Min, 500VDC
Resistance Accuracy:	±10%	Dielectric Strength:	500VDC for one minute
Inductance Accuracy:	±20%	Radial Play:	0.02" at 1.0 lbs
Temperature Rise:	80°C Max (2 Phases On)	End Play:	0.08" at 1.0 lbs
Ambient Temperature:	-20° to +50°C	Max Radial Force:	4.5 lbs (0.79" from flange)
Insulation Type:	Class B (130°C Internal)	Max Axial Force:	2.2 lbs-Force