

17YPG Series - High Torque Stepper Gearmotor

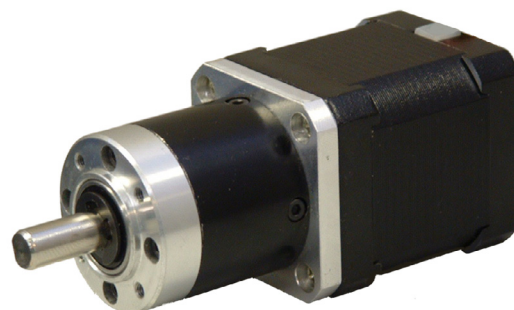

FEATURES

- NEMA Size 17 Integrated Gearmotor
- High-Torque Stepper Motor
- Economy Planetary Gearbox
- High Torque - Up to 1250 oz-in
- Gear Ratios: 3.7:1 to 720:1
- 1.8° Step Angle
- Backlash Less Than 3 Degrees
- Can be Customized for
 - Winding Currents
 - Shaft Options
 - Cables and Connectors
- CE Certified and RoHS Compliant



DESCRIPTION

The 17YPG Series gearmotor incorporates a high-torque stepper motor and an economic planetary gearbox to offer you an exceptional value. This compact package can deliver torque up to 1250 oz-in, with a wide range of gear ratios and motor currents available. This gearmotor is ideal for applications that require high torque in a small package. The backlash for the gearbox is less than 3 degrees and should not be used for applications requiring high accuracy or precision. The gearmotor can be customized to perfectly match your voltage, current, and maximum operating speed for maximum flexibility.

DIMENSIONS

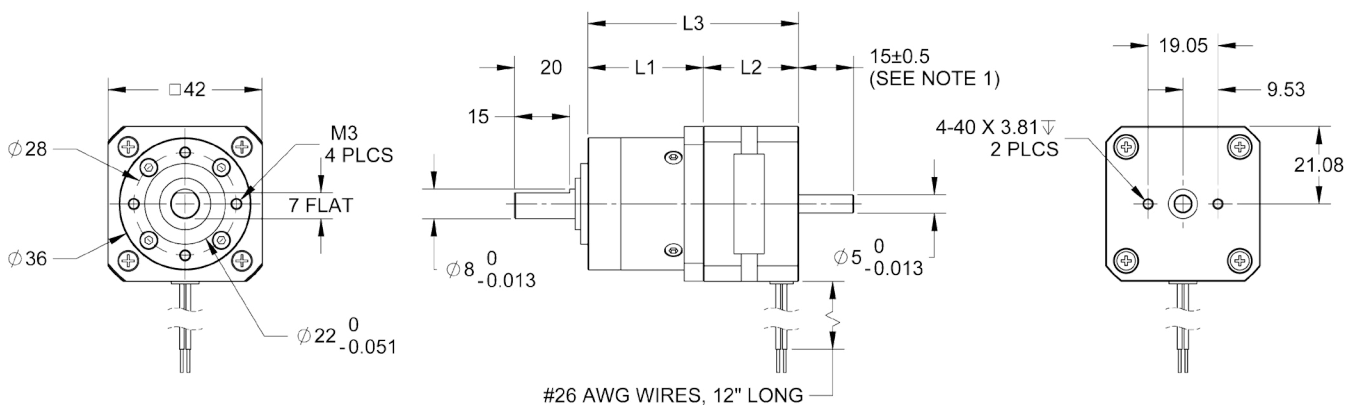

Note 1: Dual Shaft Option

WIRING

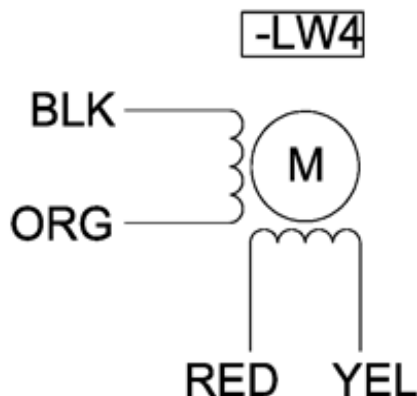

L010469

- Speed of the output shaft (after gearbox) = (Motor Speed)/(Gear Ratio)
- Torque of the output shaft (after gearbox) = (Motor Torque/) X (Gear Ratio)
- Rotor Inertia of the output (shaft after gearbox) = (Rotor Motor Inertia) X (Gear Ratio)²

Create a complete Model Number by selecting a motor from Table 1 and Gearbox from Table 2

17YPG001S - LW4 - R3.7

Table 1	Output Shaft of Motor Before Gearbox									
Model #	NEMA Size	Bipolar Torque (oz-in)	Bipolar Current (A)	Bipolar Voltage (V)	Bipolar Resistance (ohm)	Bipolar Inductance (mH)	Rotor Inertia (oz-in-sec ²)	# of Lead Wires	Weight (lbs)	"L2" Length (mm)
17YPG001S-LW4	17	24	0.40	9.6	24	30	0.00028	4	0.33	26
17YPG101S-LW4	17	28	0.28	12.04	43	49	0.00054	4	0.44	34
17YPG102S-LW4	17	28	0.71	4.5	7.3	10	0.00054	4	0.44	34
17YPG201S-LW4	17	50	0.28	16	56	90	0.00076	4	0.62	40
17YPG202S-LW4	17	50	0.85	5.61	6.6	10	0.00076	4	0.62	40
17YPG301S-LW4	17	61	0.28	19.32	69	103	0.00096	4	0.77	48
17YPG302S-LW4	17	61	0.85	5.61	6.6	11	0.00096	4	0.77	48
17YPG402S-LW4	17	111	0.85	10.2	12	29	0.00144	4	1.10	60

Gearbox Ratio (R)	Exact Reduction Ratio	Rated Torque (oz-in)	Max Torque (oz-in)	Efficiency	L1 (mm)	Weight (lbs)
R3.7	3.71	42	139	90%	31.0	0.42
R5.2	5.18	42	139	90%	31.0	0.42
R14	13.76	139	417	81%	40.0	0.46
R19	19.22	139	417	81%	40.0	0.46
R27	26.83	139	417	81%	40.0	0.46
R51	51.06	278	833	73%	50.0	0.63
R71	71.30	278	833	73%	50.0	0.63
R100	99.55	278	833	73%	50.0	0.63
R139	138.99	278	833	73%	50.0	0.63
R189	189.45	417	1250	66%	56.9	0.69
R264	264.52	417	1250	66%	56.9	0.69
R369	369.32	417	1250	66%	56.9	0.69
R516	515.66	417	1250	66%	56.9	0.69
R720	719.98	417	1250	66%	56.9	0.69

SPECIFICATIONS

Housing Material:	Metal	Radial Play at Shaft:	0.04mm
Bearing at Output:	Ball Bearing	Thrust Play at Shaft:	0.3mm
Radial Load:	11.02lbs	Backlash, at No-Load:	3°
Shaft Axial Load:	7.72lbs	Shaft Press Fit Force, Max:	33.07lbs
Step Angle Accuracy:	± 5% (Full Step, No Load)	Ambient Temperature:	-20° to +50° C
Resistance Accuracy:	± 10%	Insulation Type:	Class B (130°C Internal)
Inductance Accuracy:	± 20%	Insulation Resistance	100M Ohm Min, 500VDC
Temperature Rise:	80°C Max (2 Phases On)	Dielectric Strength:	500VAC for 1 minute
Gearbox Shaft Diameter:	8mm		

Note: Custom leadwires, cables, connectors, and windings are available upon request.