

23MD Series Motor / Driver Combination SPEC SHEET

- **Step Motor / Microstep Driver Combination**
- **Eliminates Motor Wires**
- **Encoder Options Available**
- **Microstep Divisors of 8, 4, 2, or Full Step**
- **Compact Package**
- **12-24V Power Requirement**
- **TTL Logic or 24V Level Inputs Available**
- **Ideal for Precise Positioning**
- **0.225° Resolution at Eighth Step**
- **Efficient and Durable**
- **Long Life Expectancy**

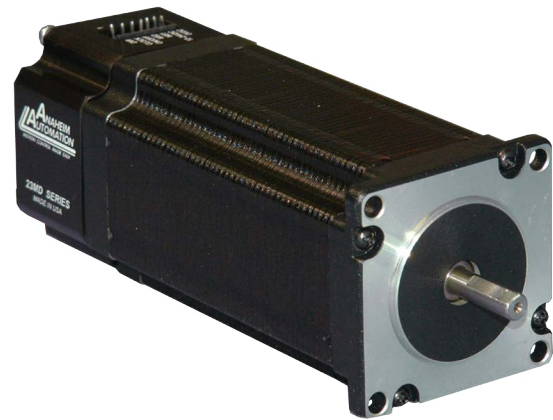

The 23MD Series is a compact construction that implements a microstepping driver and a step motor in one streamline package. With the two parts combined into one casing, the need to include motor wires has been eliminated. The high-torque step motor can generate up to 230 oz-in of torque. The microstepping driver will operate off 12VDC minimum to 24VDC maximum with a maximum power intake of 40W. The inputs are capable of running from either open collector or TTL level logic outputs, or sourcing 24VDC outputs from PLCs. The microstepping driver features resolutions from 200 - 1600 steps/revolution, providing smooth rotary operation. The 23MD series comes in either a single shaft version or a double shaft version with optional encoder and motor stack lengths of 1/2, 1, 2, or 3 allowing for varying amounts of start-up torque and inertia. Standard motors that have the 04 and 10 encoder part number call out, do not come with an index. An index channel as well as other CPR options are available on special request. The 23MD series features include built in over temperature and short circuit shut down, automatic 70% reduction in current after clock pulses stop being received, and status LED's to indicate power on (Green LED) and clocks being received (Yellow LED).

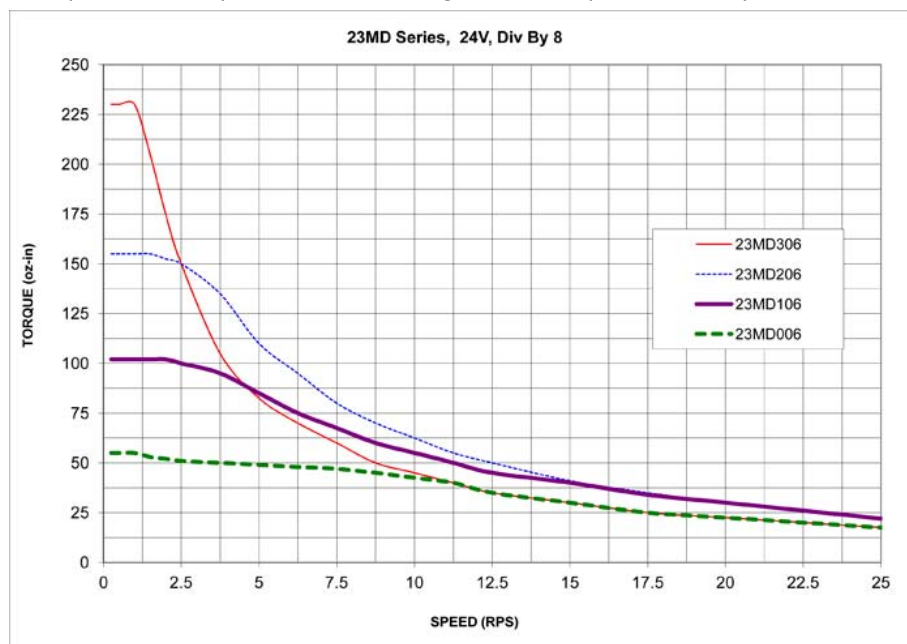

ANAHEIM AUTOMATION

4985 E. Landon Drive Anaheim, CA 92807
e-mail: info@anaheimautomation.com

(714) 992-6990 fax: (714) 992-0471
website: www.anaheimautomation.com

Hook-Up Drawings

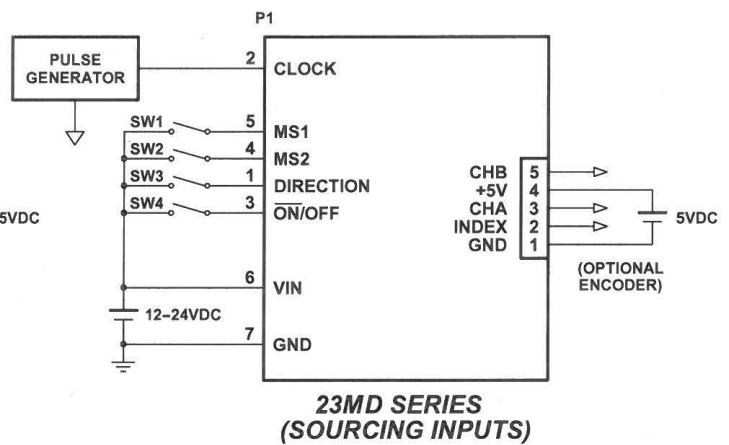
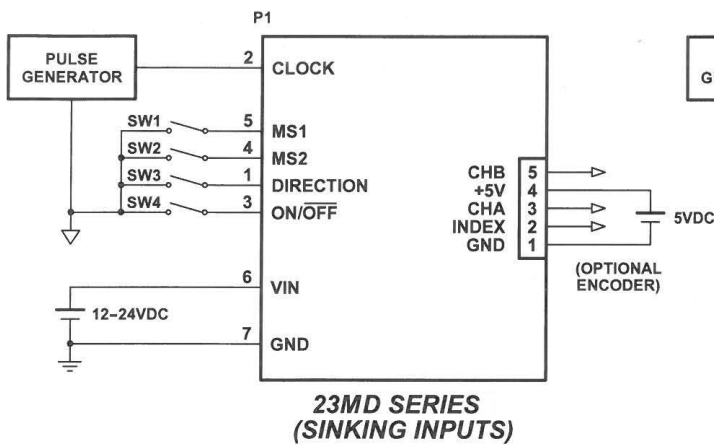

Input Pin Descriptions

Pin #	Description	CBL-AA4031 Wire Color
1	Direction	Brown
2	Clock	Red
3	On/Off	Orange
4	MS2	Yellow
5	MS1	Green
6	12VDC-24VDC	Blue
7	0VDC (Gnd)	Violet

Encoder Pin Descriptions

Pin #	Description	CBL-AA4032 Wire Color
1	0VDC (Gnd)	Brown
2	Index (Optional)	Red
3	Channel A	Orange
4	+5VDC	Yellow
5	Channel B	Green

Control Inputs (Pins 1, 2, 3, 4, 5):

Microstep Resolution Truth Table

MS1	MS2	Resolution
Active	Active	Full Step
Inactive (Open)	Active	Half Step
Active	Inactive (Open)	Quarter Step
Inactive (Open)	Inactive (Open)	Eighth Step

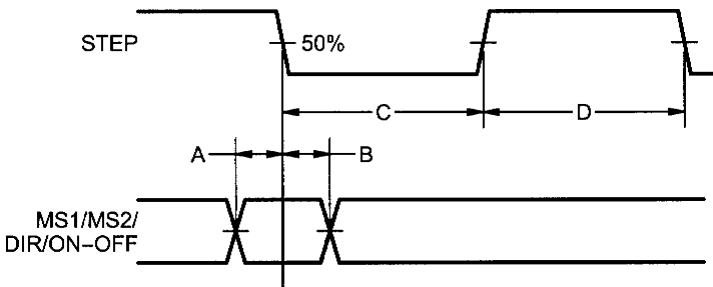

Direction: Logic "1" CW
Logic "0" CCW

Clock: Active - 1 Step
Inactive (open) - Reduce Current Mode

On/Off: Active - Off
Inactive (open) - On

Note:

Open Inputs are inactive and internally pulled up to +5VDC for 23MDX06X-XX-00-00 (Sinking)

Open Inputs are inactive and internally pulled down to 0VDC for 23MDX06X-XX-24-00 (Sourcing)

- A. Minimum Command Active Time Before Clock Pulse (Data Set-Up Time) ... 200nS
- B. Minimum Command Active Time After Clock Pulse (Data Hold Time) 200nS
- C. Minimum CLOCK Pulse Width 1.0uS
- D. Minimum CLOCK Off Time..... 1.0uS
- Maximum CLOCK Frequency 500kHz

For the sinking version (23MDX06X-XX-00-XX) the inputs are considered inactive or Logic "1" if left open, or active or Logic "0" if grounded. For the sourcing version (23MDX06X-XX-24-XX) the inputs are considered inactive or Logic "0" if left open, or active or Logic "1" if pulled to 3.5 - 24VDC.

Single-Ended Shaft Dimensions

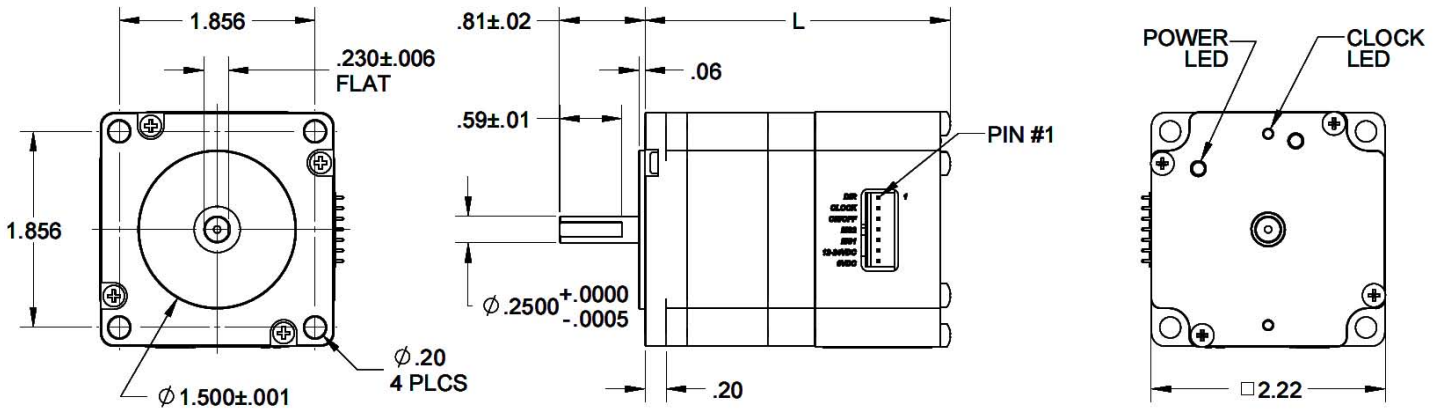

*All units in inches

** For the 23MD206S-00-xx-00 the mounting holes are tapped with a M6x1.0 thread thru

Double-Ended Shaft with Encoder Dimensions

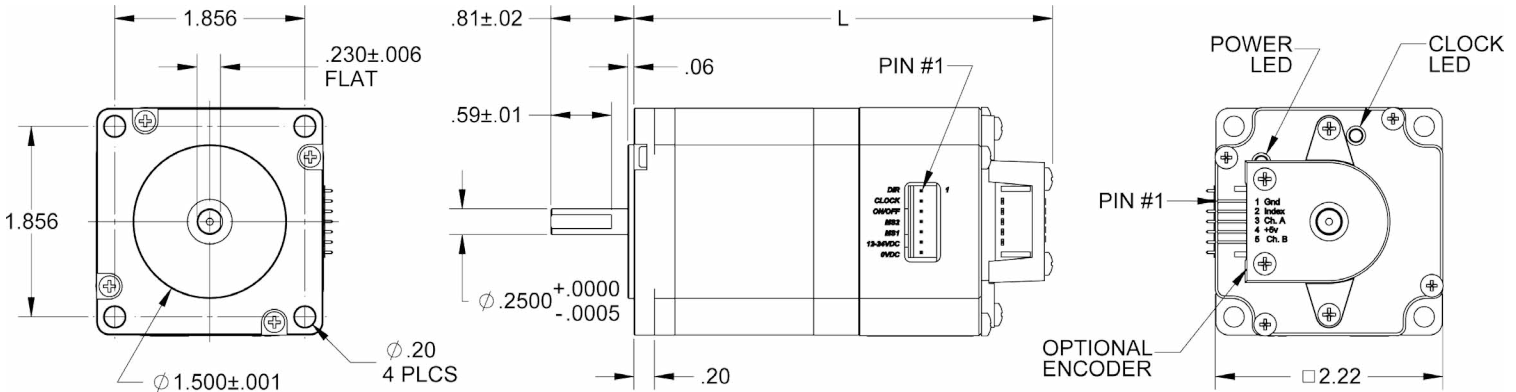

Double-Ended Shaft without Encoder Dimensions

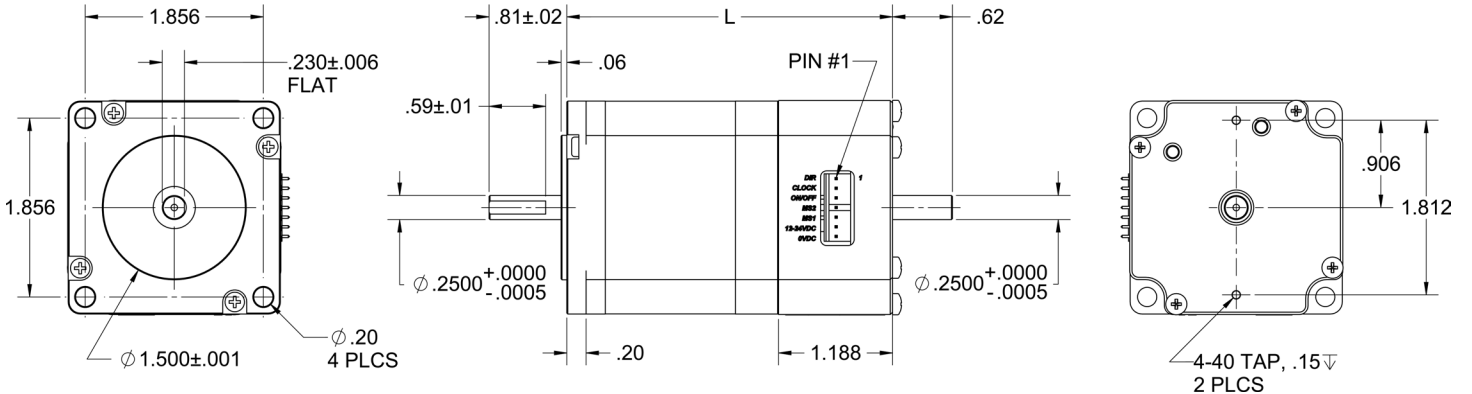

Model	Length	Model	Length
23MD006S-00-00-00	2.90"	23MD006D-00-00-00	2.80"
23MD006S-00-24-00	2.90"	23MD006D-00-24-00	2.80"
23MD106S-00-00-00	3.49"	23MD106D-00-00-00	3.39"
23MD106S-00-24-00	3.49"	23MD106D-00-24-00	3.39"
23MD206S-00-00-00	4.28"	23MD206D-00-00-00	4.18"
23MD206S-00-24-00	4.28"	23MD206D-00-24-00	4.18"
23MD306S-00-00-00	5.82"	23MD306D-00-00-00	5.72"
23MD306S-00-24-00	5.82"	23MD306D-00-24-00	5.72"

Model	Length	Model	Length
23MD006D-04-00-00	3.50"	23MD206D-04-00-00	4.87"
23MD006D-04-24-00	3.50"	23MD206D-04-24-00	4.87"
23MD006D-10-00-00	3.50"	23MD206D-10-00-00	4.87"
23MD006D-10-24-00	3.50"	23MD206D-10-24-00	4.87"
23MD106D-04-00-00	4.08"	23MD306D-04-00-00	6.42"
23MD106D-04-24-00	4.08"	23MD306D-04-24-00	6.42"
23MD106D-10-00-00	4.08"	23MD306D-10-00-00	6.42"
23MD106D-10-24-00	4.08"	23MD306D-10-24-00	6.42"

Ordering Information - Use the chart to create your specific part number

Model Series	Motor Length	Shaft Options	Encoder Options	Sourcing or Sinking	Special Options
23MD	106	S	-00	-00	-00
006, 106, 206, 306					
S - Single-Shaft, D - Double-Shaft with Optional Encoder Mounted					
-00 - No Encoder -04 - 400 Line Encoder without Index -10 - 1000 Line Encoder without Index Other options will be made available as requested					
-00 - Sinking Inputs -24 - Sourcing Inputs					
-00 Standard Product Other options will be created as needed					

Note: Standard motors that have 04 and 10 Encoder part numbers, do not come with an index. Index channel is available on special request.

Accessories Ordering Information

Part Number	Description
CBL-AA4031	7 Pin Input Connector with 12" Leads
CBL-AA4032	5 Pin Encoder Connector with 12" Leads
PSAM24V2.7A	24V @ 2.7A Universal Input Power Supply
PSAM24V1.2A-5V3.5A	24V @1.2A and 5V @ 3.5A Universal Input Power Supply
CON-6404407	7 Pin Connector with 0.100" Centers (Amp #640440-7)
CON-6404405	5 Pin Connector with 0.100" Centers (Amp #640440-5)

ANAHEIM AUTOMATION