

MBC20SC1

Step Motor Controller/Driver

User's Guide

Product Image Here



ANAHEIM AUTOMATION, INC.

4985 E. Landon Drive Anaheim, CA 92807
e-mail: info@anaheimautomation.com

(714) 992-6990 fax: (714) 992-0471
website: www.anaheimautomation.com

Table of Contents

Section 1: introduction	3
Description	3
Methods of Communication	4
Baud Rate	4
Device Address	4
Operating Modes	4
Current and Operating Temperature	4
Torque Curve Examples	4
Electrical Specifications	5
Ordering Information	5
Translating Speed Configurations to RPM	5
Dimensions	6
Wiring Diagram	6
Terminal Descriptions	7
Connector Descriptions	7
Section 2: Functions	9
Section 3: MBC20WIN Software	13
Software Overview	14
Toolbar	14
Setup Menu	15
Help Menu	15
Connected/Disconnected	16
Motion Control	17
Ramp Configurations and Status	18
Encoder Configurations and Status	19
Tab Sheets	20
Section 4: Direct Talk Mode	23
Section 5: Troubleshooting	33

Section 1: Introduction

The MBC20SC1 is step motor driver that provides simple and flexible control of stepper motors with quadrature encoder feedback. The easy-to-use Windows software, MBC20WIN, can be used to directly control motion and configure the MBC20SC1. The MBC20SC1 also has the ability for real time functions/configuration changes. “Direct Mode” is used to directly control the device and execute real time moves through serial communication.

The MBC20SC1 has 43 commands, Which makes the device highly configurable for direct movement of a stepper motor. The MBC20SC1 communicates via a Universal Serial Bus (USB). A windows driver is provided to communicate with the MBC20SC1 through a virtual comport from the PC. This driver will turn any USB port into a virtual comport, thus enabling simple serial programs to send information to the MBC20SC1. To use the MBC20WIN software, the virtual comport driver must be installed. Special functions of the MBC20SC1 include a quadrature encoder input with the ability to autocorrect. The MBC20SC1 can be powered with a DC voltage of 10-30VDC and uses only 1200 milliwatts at 10VDC and only 1440 milliwatts at 30VDC (with no connections to terminal blocks and a current scale of 31/16 {Run/Hold}).

Description

The MBC20SC1 step motor driver provides independent configuration of base speed (starting speed), middle speed threshold, max speed (running speed), base acceleration/deceleration (starting acceleration), max acceleration/deceleration (secondary acceleration after middle speed threshold), motor run/hold current (up to 2.0A per coil), and the number of steps to be taken in both relative and absolute positioning modes.

The inputs of the driver consist of a REFL and REFR inputs (which can be configured as either soft/hard stops in digital mode or STEP and DIR in STEP/DIR mode), an on/off input, a Slew/Index toggle, Index 1 and Index 2. The inputs are in-active high at 5VDC and must be grounded to activate them. A downloadable package at www.anaheimautomation.com/software contains this user's manual, along with the MBC20WIN software, and USB drivers. The software allows you to change the driver's configurations that can be stored in the MBC20SC1's on-board memory for autostart use.

Methods of Communication

There are two methods for sending commands to the MBC20SC1. One is to directly talk to the MBC20SC1 by using Direct Talk Mode. This is usually used with a computer, where the computer gives the MBC20SC1 serial commands. A windows driver is provided to communicate with the MBC20SC1 through a virtual comport from the PC. The driver can be found in the drivers folder in the device's downloadable software package. The second way to give commands to the MBC20SC1 is to use the software program MBC20WIN to configure and manually control the driver.

Baud Rate

A term used frequently in serial data communications, a “baud” is defined as the reciprocal of the shortest pulse duration in a data word signal, including start, stop, and parity bits. This is often taken to mean the same as “bits per second”, a term that expresses only the number of “data” bits per second. Very often, the parity bit is included as an information or data bit. **The virtual comport that communicates with the MBC20SC1 through the computer's USB port accepts a baud rate of 38400 only.**

Device Address

Each MBC20SC1 is addressed using a programmable register allowing the PC to address up to 99 controllers. The Default device address is “0”. To change the device address, use the MBC20WIN software or the “~” command. To verify the current device address, use the MBC20WIN software or the “%” command. The device address designation is nonvolatile (When configuration is saved with the “SV” command) and will remain the same until changed by the user.

Operation Modes

The MBC20SC1 provides two methods of operating and driving a motor. A STEP/DIR mode, in which a clock input can be provided to the REFL/STEP input to drive the motor, and a switch can be attached from REFR/DIR to GND in order to control direction of motion. This allows the user to fine tune and have more control over the motion. The second operation mode is digital mode where the motion of the driver is entirely configured through commands sent in direct talk mode or configured using our easy-to-use MBC20WIN software.

Current and Operating Temperature

The MBC20SC1 makes it easy to adjust both the motor current during motion and a standstill in either the MBC20WIN software or through “direct talk” mode. To do this, the MBC20SC1 uses a custom current scaling value that ranges between 0 – 31 (0.04A RMS – 1.35A RMS), which allows the user to adjust the current to match the requirements of the motor being used. While the user is allowed to push higher current depending on their application, it is highly recommended to utilize forced air cooling when operating at a current scale of 23 or higher to prevent overheating of the driver. It is also recommended that holding current is set at 30 - 50% of the running current for optimal temperature and performance. With optimal cooling, the MBC20SC1’s max operating temperature can be decreased by up to ~35%.

Torque Measurements and Comparisons

The MBC20SC1 can drive high-torque stepper motors despite its small package. However, due to the differences in STEP/DIR and Digital modes, and how they operate within the driver, there are performance differences to consider when deciding between which mode of operation for a specific application. STEP/DIR mode would consistently measure at a peak torque ~1% less than Digital mode, while also reaching a max speed with load ~27% less than the max speed with load of Digital mode.

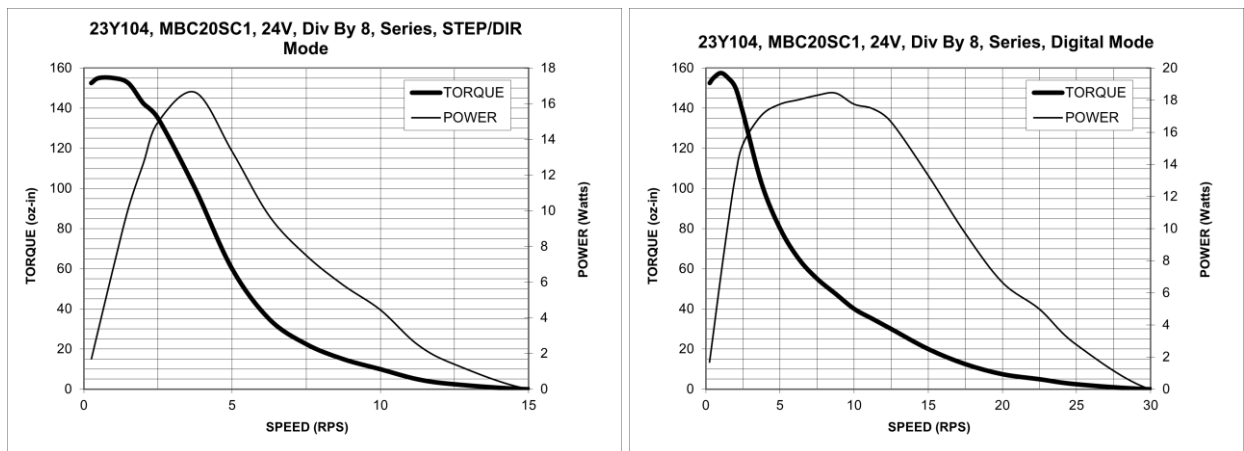

Electrical Specifications

Power Requirements with No Connections:

10-30VDC @ 50 - 60 mA

Baud Rate

38400 Baud, Fixed

Operating Temperature

0 to 125 °C

Data Format:

Full-Duplex, 1 start bit, 8 data bits, no parity, 1 stop bit

Encoder and Driver Outputs:

+5VDC Output, 1000mA (total)

Ordering Information

Part Number	Description
MBC20SC1	Featured step motor driver with encoder feedback.
PSAM24V2.7A	Power Supply for MBC20SC1 (24V @ 2.7A)
23Y104S-LW8	2.0A, 1.8° step angle, high torque stepper motor.
AAUSB-ABMINI-6	USB-A to Mini USB-B communication cable.

Translating Speed Configuration to RPM

$$RPM = \frac{60 * (Speed * (7.86781311 * 10^{-2}))}{Microstep Div \left(Motor \frac{Fullsteps}{Revolution} \right)}$$

*Speed is either Base/Middle/Max Speed values

Dimensions

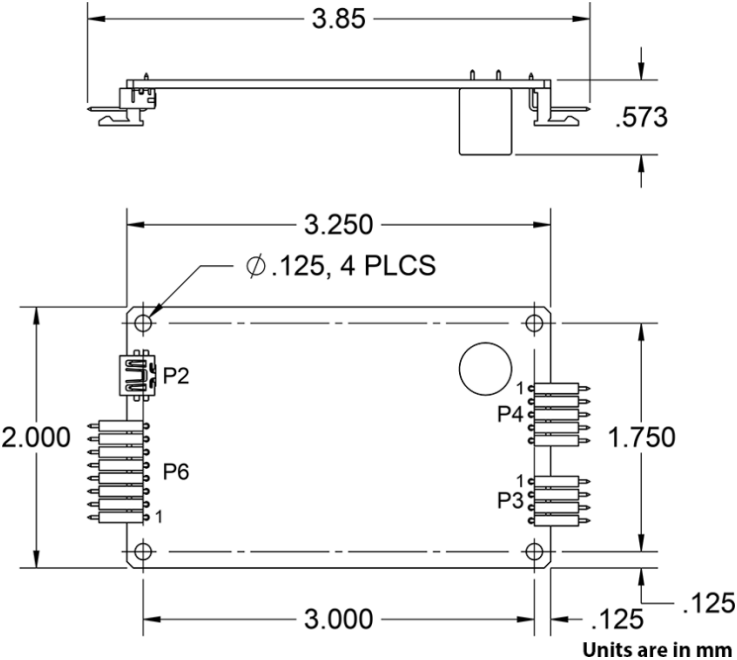

Wiring Diagrams

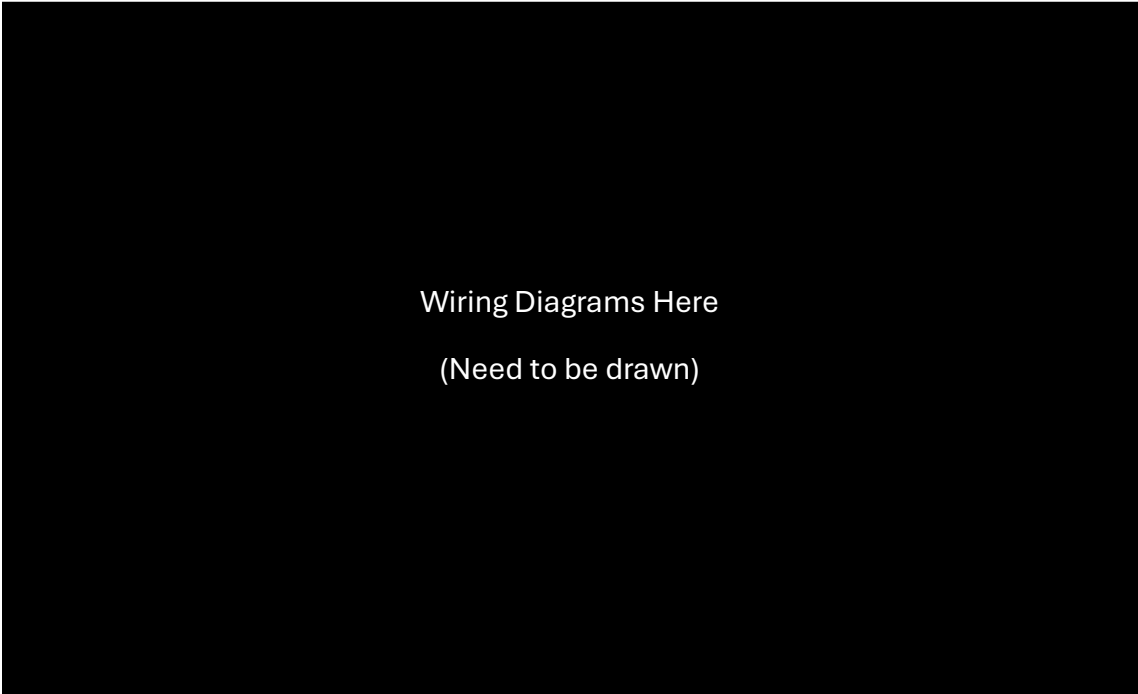

Terminal Descriptions

Position	Description – Power & Inputs
1	Slew+/Index Profile 1
2	Slew-/Index Profile 2
3	Slew/Index Toggle
4	On/Off
5	REFL/STEP
6	REFR/DIR
7	10-30VDC Power Input
8	Ground Power Return

Position	Description – Encoder
1	+5VDC supply for encoder
2	Channel A for encoder
3	Channel B for encoder
4	Channel N for encoder (Optional)
5	Ground return for encoder

Connector Descriptions

Position	Description – Motor Phases
1	Phase /B
2	Phase B
3	Phase A
4	Phase /A

Position	Description
P2	This connector is for the Mini USB communication.

Section 2: Functions

Move Number of Steps: This command will move the number of steps given. (Range: 0 to $2^{31} - 1$)

Move to Position: The move to position command specified the next absolute position to go to. The MBC20SC1 automatically sets the direction and number of steps needed to go to that position. (Range: $\{-2^{31} \text{ to } 2^{31}\} - 1$)

Set Position: The set position command sets the position register to a designated value. The number will be the new absolute position of the motor. The default value is 0. (Range: $\{-2^{31} \text{ to } 2^{31}\} - 1$)

Slew: The slew command will accelerate the motor up to maximum speed and continue to run at that speed until receiving a "." (Hard Stop) or "," (Soft Stop) command. All configurations (aside from direction, microstep division and emergency/hard stop) are not available while motor is ramping to max speed, so it is highly recommended that configurations are not changed during the ramp stage to avoid unexpected outcomes.

Home Limit Input: This switch is used to establish a position designated "home" or datum position using home or "home-to-home" limit. The home limit input is determined by the direction the motor is traveling, if the motor is moving clockwise, then the home limit input is REFR and vice versa. The reference input in the opposite direction of travel is used as the soft home limit input.

Home Limit: In this home routine, the motor moves toward the home limit switch. When the home limit switch is contacted, the motor will hard stop.

Home to Home Limit (1 Switch Operation): In this home routine the motor moves toward the home limit switch. When the home limit switch is contacted, the motor will ramp down to base speed, reverse direction and continue at base speed until the limit switch is released. This is a good way to compensate for any backlash in a system. NOTE: The home switch needs to be activated during the entire deceleration and reversing time.

Soft Home to Home limit (2 Switch Operation): In this home routine the motor moves toward the home limit switch. When the soft home limit switch is contacted, the motor will ramp down to base speed, then continue at base speed until the home switch limit switch is contacted.

Inputs: All inputs are internally pulled up by a resistor making them normally +5 volts. To activate the input, the pin must be grounded to 0VDC. Four inputs are provided correlating to On/Off, Slew/Index toggle, Slew-/Index 2, and Slew+/Index 1; The inputs are TTL and CMOS compatible.

On/Off Input (IN 4): The On/Off input allows the user to manually control the driver current. When connected via a toggle switch to GND, the user can toggle the switch on to shut off the driver. This will end any process the driver is currently running and cut off the current to the motor putting it into a freewheeling state. NOTE: Since the driver will be offline, any configurations or commands in direct talk mode will not function until the switch is toggled off.

Slew/Index Input (In 3): This input determines whether inputs 1 or 2 are used as Slew-/+ or used as Indexes. By default, this input is set as “Slew”, which means inputs 1 and 2 are Slew+ and Slew- respectively. If this input was connected to GND via a switch, then inputs 1 and 2 would instead be Index 1 and 2 respectively.

Slew+/Index 1 (In 1): This input depending on the state of the Slew/Index input, will either perform a Slew+ (clockwise) movement or a user programmed Index move. In slew mode, the input will slew in the clockwise direction for as long as the input is held. In Index mode, the input will perform an index movement based on what the user programmed to the index in either the MBC20WIN software or direct talk.

Slew-/Index 2 (In 2): This input depending on the state of the Slew/Index input, will either perform a Slew- (counter-clockwise) movement or a user programmed Index move. In slew mode, the input will slew in the counter-clockwise direction for as long as the input is held. In Index mode, the input will perform an index movement based on what the user programmed to the index in either the MBC20WIN software or direct talk.

Index Programming: The MBC20SC1 driver provides 2 programmable indexes which correlates to Index 1 and Index 2 on the terminal inputs. This can be programmed to perform a variety of functions such as go number of steps, go to position, set position, and slew.

Encoder Commands: The MBC20SC1 driver is capable of using a quadrature incremental encoder with A and B channels.

Encoder Motor Ratio: This represents the ratio for the number of encoder pulses to one motor step. The motor ratio is calculated with the following formula (FSC = Motor FullStep Count; USC = Microstep Division):

$$Enc\ Motor\ Ratio = \frac{FSC * USC}{Encoder\ Count * 4}$$

For example, given a 1000-line quadrature encoder, a 400 step/revolution motor, and a microstep division of 256, the motor ratio is $(400 * 256) / (1000 * 4) = 25.6$ (Range: 1 to 255)

Encoder Autocorrect: This command will enable or disable the encoder feature of the MBC20SC1. When enabled, the encoder function will compare the desired position with the actual encoder position. If it is not in the correct position a correction move will be made.

Encoder Delay: This sets the wait time, which is a specified number of milliseconds after a relative index or absolute move is finished, prior to reading the encoder. This is used to remove the ringing that might be associated with the mechanics of the system. (Range: 0 to 65535)

Encoder Home: This homes the motor shaft to a known home position of the encoder. This function requires an encoder with an index signal. (0 – 3)

Encoder Revolutions: This sets the number of revolutions that the user wants the driver to perform. This function requires an encoder with an index signal. (Range: 0 to 255)

Encoder Retries: This is the number of times the MBC20SC1 will try to autocorrect the motor shaft position. (Range: 0 to 255)

Encoder Window: This is the allowable error in encoder pulses (either plus or minus) from the desired position that is allowed before the motor autocorrects. (Range 0 to 255)

Base Speed: The base speed is the speed at which motion starts and stops. It is entered directly as the number of microsteps per second ($\frac{usteps}{sec}$). This speed must always be less than the middle threshold and max speed. (Range: 1 to 50,000)

Middle Speed Threshold: The middle speed threshold is the speed at which the motor switches from the base acceleration/deceleration to the max acceleration/deceleration. This can be disabled by setting the threshold to 0, in which the motor will only use the max acceleration/deceleration values. It is entered directly as the number of microsteps per second ($\frac{usteps}{sec}$). NOTE: If enabled, must be a value between base and max speed. (Range: 1 to 500,000)

Max Speed: The max speed is the top speed the user wants the motor to run. This speed must always be greater than the base speed and middle speed threshold. It is entered directly as the number of microsteps per second ($\frac{usteps}{sec}$). (Range: 1 to 1,000,000)

Base Acceleration/Deceleration: The base acceleration/deceleration are individual configurable values. These define the initial acceleration or deceleration of the motor upon starting or stopping a movement up to the middle velocity threshold. It is entered directly as the number of microsteps per second² ($\frac{usteps}{sec^2}$). (Range: 100 to 65,535)

Max Acceleration/Deceleration: The max acceleration/deceleration are individual configurable values. These define the final acceleration or deceleration the motor switches to upon reaching the middle speed threshold up to the max speed. It is entered directly as the number of microsteps per second² ($\frac{usteps}{sec^2}$). (Range: 100 to 65,535)

Microstep Division: This sets the microstep division of the motor i.e. the number of microsteps the motor takes per fullstep. For example, given a 400 step/revolution motor and a microstep division of 4, the motor will travel $(400 * 4) = 1600$ microsteps/revolution ($\frac{usteps}{rev}$). When using an encoder, the encoder motor ratio must be recalculated when the microstep is changed. (Valid Divisions: 1, 2, 4, 8, 16, 32, 64, 128, 256).

Motor Current: This command will control the on/off output. To energize and allow current to flow through the coil of the motor, set the value to on(1). To de-energize and turn the current off to the motor, set the value to off(0). Both run and hold current can be independently controlled depending on the users needs.

Verify: The verify command causes the MBC20SC1 to send data back to the PC. The data is sent as an ASCII decimal string followed by a carriage return and a line feed. The verify command are shown on the table on page 26.

Section 3: MBC20WIN Software

The MBC20WIN Software is a highly configurable utility specifically designed for the MBC20SC1 driver. Connecting your PC to the MBC20SC1, via a USB cable, the MBC20WIN software can easily perform the following tasks:

- Exercise and monitor the MBC20SC1 driver.
- Save configurations and turn on auto start for standalone operation.
- Directly communicate with the MBC20SC1 driver.

Installation

Software

- The MBC20SC1 is provided on the Anaheim automation website. It the downloadable file contains the setup program for the MBC20SC1 software, the MBC20SC1 user manual, and example configurations.

Windows 10/11 Installation

1. Download software from the Anaheim Automation Website.
2. Unzip the file.
3. Double click on the **setup** application file.

Getting Started

1. Double click on the MBC20WIN icon to run the MBC20WIN software.
2. Apply power(10-30VDC) to the MBC20SC1 driver.
3. Set the appropriate com port setting by selecting Setup | Com Port Settings from the menu bar.
4. Set the appropriate axis setting by selecting Setup | Axis from the menu bar.
5. Establish communications with the MBC20SC1 by clicking on the Connect Icon and select Setup | Connect from the menu bar. If the unit is connected properly, the program will notify when communications have been established.

Changing the COM Port Number of the USB Port

1. From **Device Manager**, select **View Device by Type**, then **Ports(COM & LPT)**. Select the USB serial port and click **Properties**. Select the **Port Settings** tabs, then click **Advanced**.
2. Choose the required COM port number from the list and click **OK**.

*Insert the rest of Section 3: here

Software Overview

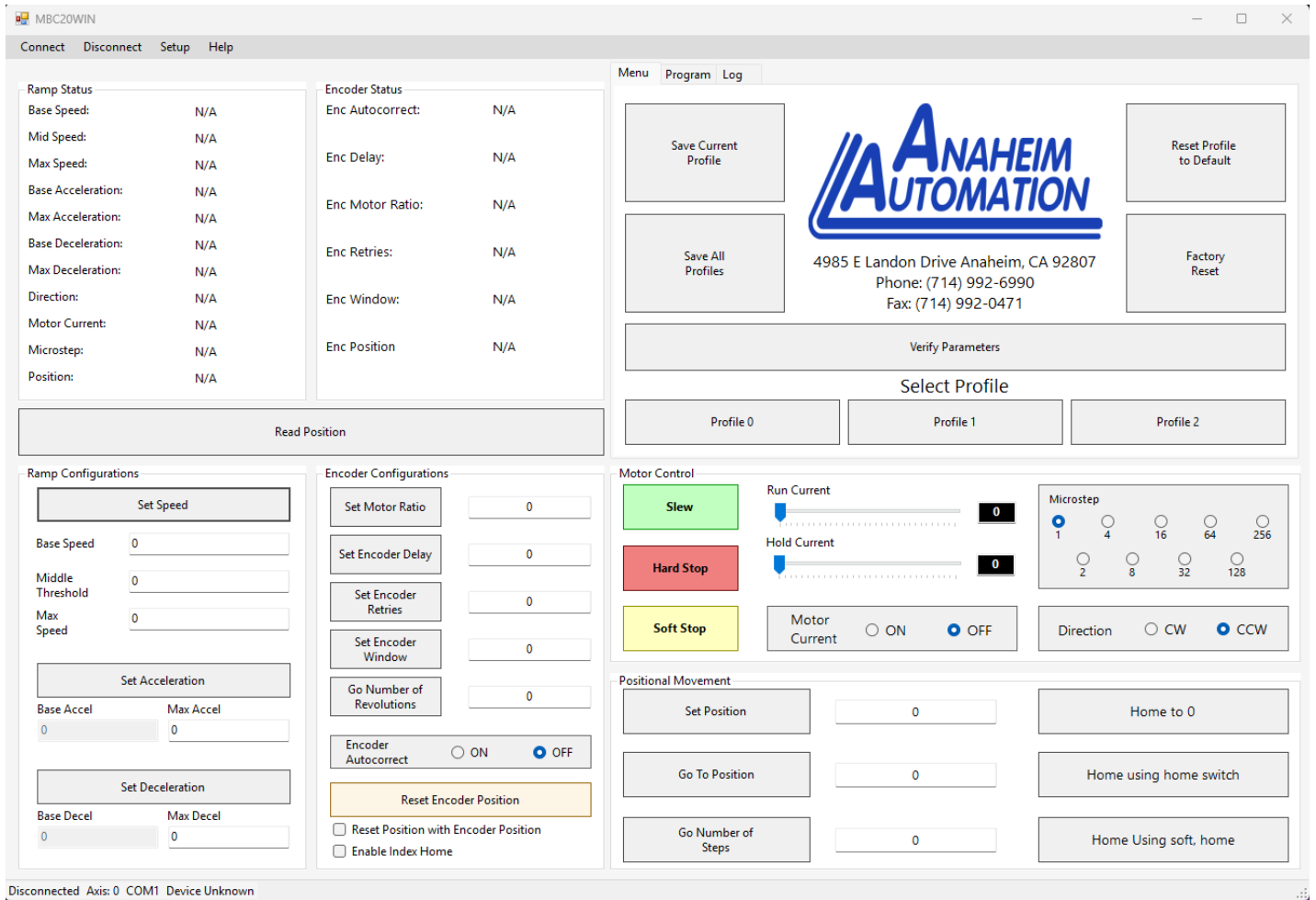

Toolbar

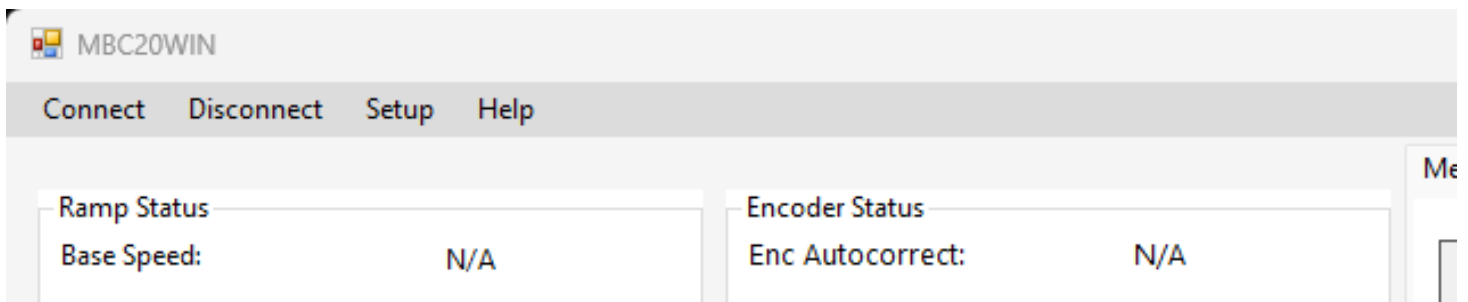

Connect	Connect to the unit with the current communication parameters.
Disconnect	Disconnect from the unit.
Setup	Set up communication parameters to the controller.
Help	Access resources relating to the MBC20SC1.

Setup Menu

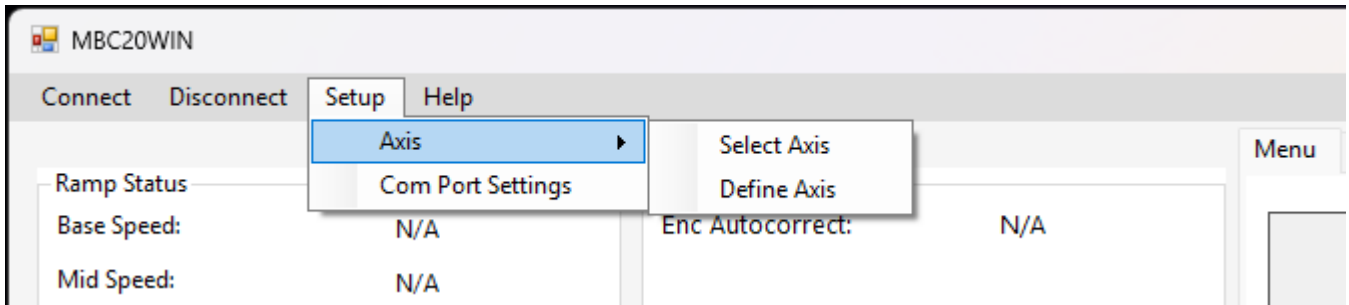

Select Axis	Select the axis of the driver to communicate to.
Define Axis	Set the axis of the selected driver.
Com Port Settings	Select COM port.

Help Menu

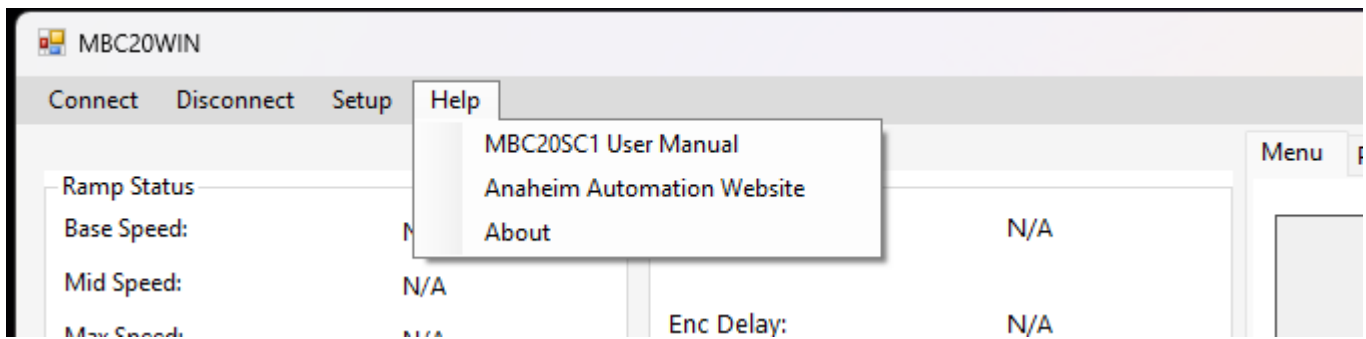

MBC20SC1 User Manual	Opens the user manual
Anaheim Automation Website	Opens the Anaheim Automation website
About	Gives details about the MBC20WIN software

“Connected” / “Disconnected”

On the bottom left of the program window, the user will find the communication status of the MBC20 controller/driver. If communications are not established, please refer to the troubleshooting section.

Base Decel 100	Max Decel 200	<input type="checkbox"/> Reset Position with Encoder Position <input type="checkbox"/> Enable Index Home
Connected Axis: 0 COM3 Device: MBC20 Version: V1.00		
Base Decel 100	Max Decel 200	<input type="checkbox"/> Reset Position with Encoder Position <input type="checkbox"/> Enable Index Home
Disconnected Axis: 0 COM3 Device Unknown		

Motion Control

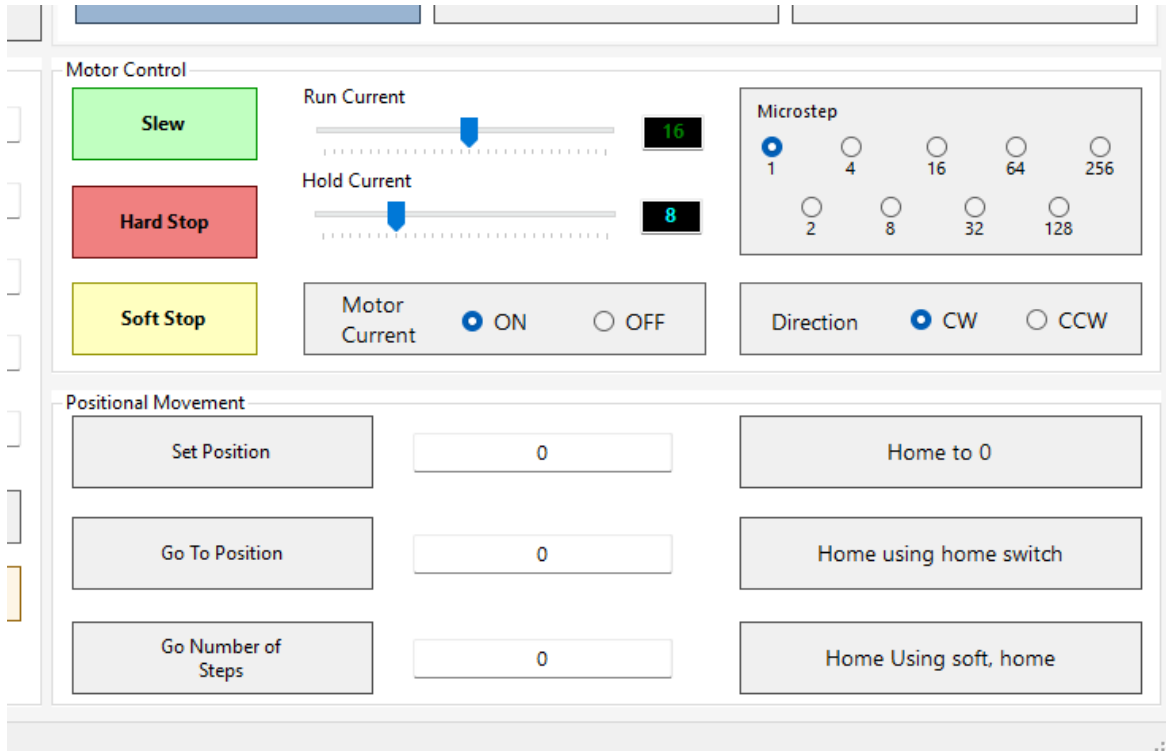

Slew	Send the slew command to the driver to start motion.
Hard Stop	Send the hard stop command to hard stop the motor.
Soft Stop	Send the soft stop command to soft stop the motor.
Run Current	Set the desired current when motor is in motion.
Hold Current	Set the desired current when motor is at standstill.
Motor Current	Set the driver current on or off.
Microstep	Send the desired microstep division to the controller.
Direction	Switch the direction of the driver CW or CCW.
Set Position	Send the new desired current position to the controller.
Go To Position	Send the position that you want the controller to move to.
Go Number of Steps	Send the number of steps that you want the controller to move.
Home to 0	Send the command to the controller to home to the 0 position.
Home using Home Switch	Send the command to home using the home limit switch.
Home Using Soft, Home	Send the command to home using the soft home and home limit switches.

Ramp Configurations and Status

The screenshot shows the MBC20WIN software interface. The top menu bar includes 'Connect', 'Disconnect', 'Setup', and 'Help'. The main window is divided into several sections:

- Ramp Status Panel (highlighted with a red border):** Displays current parameters:
 - Base Speed: 500
 - Mid Speed: 1000
 - Max Speed: 2000
 - Base Acceleration: 100
 - Max Acceleration: 200
 - Base Deceleration: 100
 - Max Deceleration: 200
 - Direction: CW
 - Motor Current: On
 - Microstep: 1
 - Position: 0
- Encoder Status Panel:** Displays encoder-related parameters:
 - Enc Autocorrect: Off
 - Enc Delay: 10
 - Enc Motor Ratio: 12.8
 - Enc Retries: 3
 - Enc Window: 5
 - Enc Position: 0
- Read Position Button:** A button labeled 'Read Position' is located below the status panels.
- Ramp Configurations Panel (highlighted with a red border):** Contains three sub-sections for setting parameters:
 - Set Speed:** Includes input fields for Base Speed (500), Middle Threshold (1000), and Max Speed (2000).
 - Set Acceleration:** Includes input fields for Base Accel (100) and Max Accel (200).
 - Set Deceleration:** Includes input fields for Base Decel (100) and Max Decel (200).
- Encoder Configurations Panel:** Contains:
 - Buttons for 'Set Motor Ratio' (0), 'Set Encoder Delay' (10), 'Set Encoder Retries' (3), 'Set Encoder Window' (5), and 'Go Number of Revolutions' (0).
 - 'Encoder Autocorrect' radio buttons: ON (unselected) and OFF (selected).
 - A yellow 'Reset Encoder Position' button.
 - Checkboxes for 'Reset Position with Encoder Position' (unchecked) and 'Enable Index Home' (unchecked).

At the bottom of the window, the status bar reads: 'Connected Axis: 0 COM3 Device: MBC20 Version: V1.00'.

Set Speed	Send Base, Middle, and Max speed parameters to controller. (<i>step/sec</i>)
Set Acceleration	Send base and max acceleration parameters to controller. (<i>step/sec²</i>)
Set Deceleration	Send base and max deceleration parameters to controller. (<i>step/sec²</i>)
Ramp Status Panel	Displays all current configurations of the motion profile.
Read Position	Verifies the position of the ramp and encoder profile.

Encoder Configurations and Status

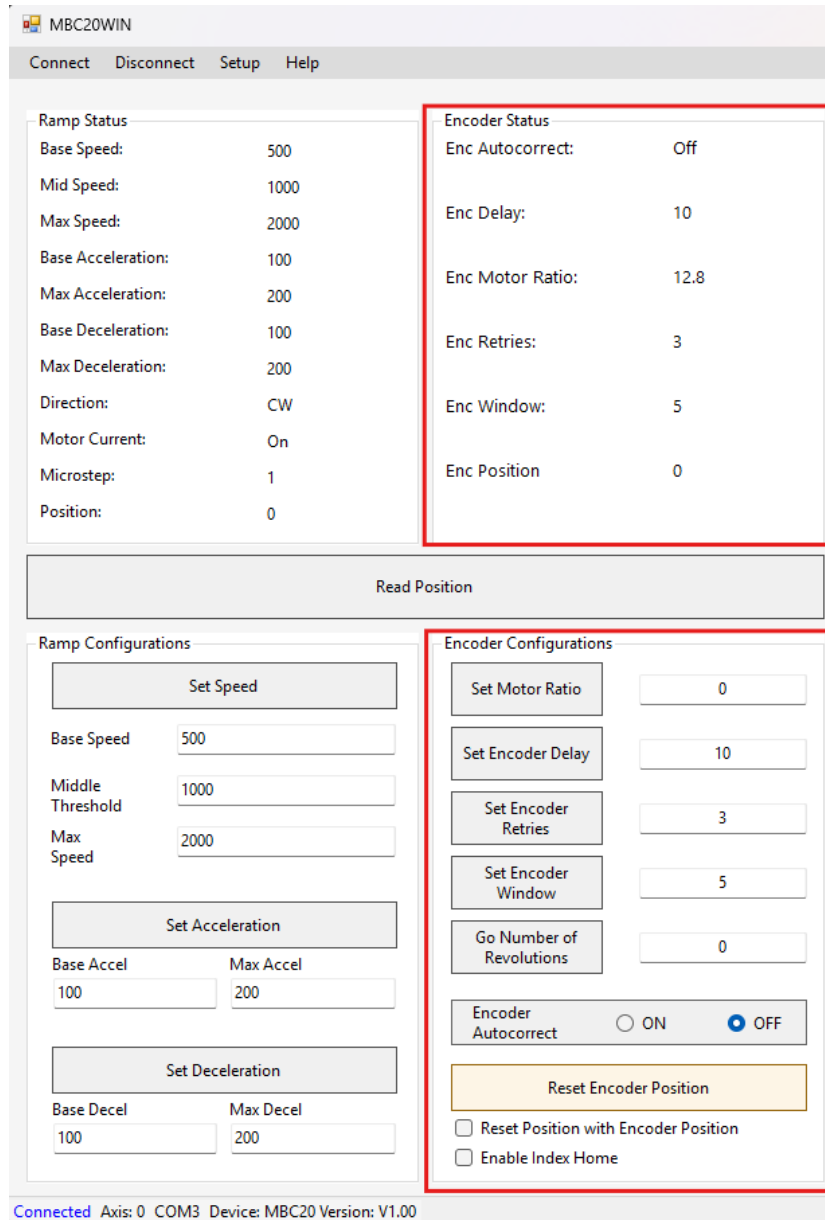

Set Motor Ratio	Send the motor ratio to the controller.
Set Encoder Delay	Send the encoder delay to the controller.
Set Encoder Retries	Send the encoder retries to the controller.
Set Encoder Window	Send the encoder window to the controller.
Encoder Autocorrect	Turn the encoder autocorrect on or off in the controller.
Reset Encoder Position	Reset the encoder position measurement in the controller.
Reset Position with Encoder Position	When enabled, ramp position will be reset with the encoder when the "Reset Encoder Position" button is pressed.
Enable Index Home	When enabled, the motor will slew until the encoder index is reached.
Encoder Status Panel	Displays all current configurations of the encoder profile.

Tab Sheet – Options

Menu
Program
Log

Save Current Profile



4985 E Landon Drive Anaheim, CA 92807
Phone: (714) 992-6990
Fax: (714) 992-0471

Reset Profile to Default

Save All Profiles

Factory Reset

Verify Parameters

Select Profile

Profile 0

Profile 1

Profile 2

Motor Control

Save Current Profile	Save the current parameters and settings to the selected profile.
Saved All Profiles	Save the parameters and settings of all profiles.
Revert Profile to Default	Reset the current settings to default (Keeps Saved parameters).
Factory Reset	Factory reset the controller to default (Erases saved parameters).
Verify Parameters	Verify the parameters of the controller. (Ramp, Encoder, etc.)
Select Profile	Select the desired profile in the controller to edit and run. Selected profile is blue.

Tab Sheet – Program

The screenshot displays the 'Program' tab with the following elements:

- Navigation:** Menu, Program (selected), Log
- Current Profile:** 0
- Command Type:** .
- Command Parameter:** 0
- Command Type (Dropdown):** None
- Command Parameter (Input):** 0
- Program Button:** A blue button labeled 'Program'.
- Profile 0 (Autostart):** Highlighted in green. Command: 'Move the motor Clockwise'. Parameter: 'S1'. Status: 'Saved'. Button: 'Select Profile'.
- Profile 1 (Index 1):** Command: 'Travel 200 steps. (Relative)'. Parameter: 'N200'. Status: 'Saved'. Button: 'Select Profile'.
- Profile 2 (Index 2):** Command: 'Travel 200 steps. (Relative)'. Parameter: 'N200'. Status: 'Saved'. Button: 'Select Profile'.
- Reference Stop:** Radio buttons for 'Hard' (selected) and 'Soft'.
- Autostart:** Radio buttons for 'ON' and 'OFF' (selected).
- Zero Enc. on Startup:** Radio buttons for 'ON' and 'OFF' (selected).
- Home Enc. on Startup:** Radio buttons for 'ON' and 'OFF' (selected).
- Note:** '*Configuration must be saved for startup options to work.'

Profile 0 (Autostart)	The default profile that is selected on powerup. Contains the command that autostarts when the device is switched on.
Profile 1 (Index 1)	A profile that correlates to "Index/Input 1" on the MBC20SC1.
Profile 2 (Index 2)	A profile that correlates to "Index/Input 2" on the MBC20SC1.
Select Profile	Selects the profile and indicates the selection in green. Loads the profile configurations.
Command Type	A dropdown menu that allows the user to select the desired command to program to the profile.
Command Parameter	An Input box that allows the user to type a desired value to the command to program into the profile.
Program	Programs the command into the selected profile and updates the register viewer.
Autostart	Toggles the autostart function on or off.
Reference Stop	Determines whether reference inputs perform a hard or soft stop when activated.
Zero Enc. On Startup	Toggles whether the MBC20SC1 zeros the encoder on startup.
Home Enc. On Startup	Toggles whether the MBC20SC1 slews the motor to the encoder index on startup.

Tab Sheet – Log

Menu	Program	Log
		[1:38:53 PM] Loading Default Config
		[1:38:53 PM] Loaded Base Speed: 500
		[1:38:53 PM] Loaded Mid Speed: 1000
		[1:38:53 PM] Loaded Max Speed: 2000
		[1:38:53 PM] Loaded Base Acceleration: 100
		[1:38:53 PM] Loaded Max Acceleration: 200
		[1:38:53 PM] Loaded Base Deceleration: 100
		[1:38:53 PM] Loaded Max Deceleration: 200
		[1:38:53 PM] Loaded Run Current: 16
		[1:38:53 PM] Loaded Hold Current: 8
		[1:38:53 PM] Loaded Position: 0
		[1:38:53 PM] Loaded Encoder Position: 0
		[1:38:53 PM] Loaded Motor Current: On
		[1:38:53 PM] Loaded Direction: CW
		[1:38:53 PM] Loaded Microstep: 1
		[1:38:53 PM] Loaded Encoder Delay: 10
		[1:38:53 PM] Loaded Encoder Motor Ratio:12.8
		[1:38:53 PM] Loaded Encoder Retries: 3
		[1:38:53 PM] Loaded Encoder Window: 5
		[1:38:53 PM] Successfully connected to unit. (MBC20, COM3, 0)

Log Output	Displays all actions taken by the user in the current session.
------------	--

A – Autostart

Format: A[0 or 1]

Description: This command runs the program on device upon power up.

Range: 0 - 1

BA – Base acceleration

Format: BA[value]

Description: This command sets the base acceleration value. The higher the value, the higher the acceleration. This is the acceleration value until the motor speed passes the middle speed threshold. Once it passes the middle speed threshold, the device switches to using the max acceleration value.

Range: 0 - 1

BD – Base deceleration

Format: BD[value]

Description: This command sets the base deceleration value. The higher the value, the faster the motor will decelerate to zero. Once the motor passes through the middle speed threshold, the base deceleration is replaced with the max deceleration value.

Range: 0 - 65,535

BS – Base speed

Format: BS[value]

Description: This command sets the base (start) speed for motion. This value must be set before motion is started. Depending on the microstep division, this setting may not be reflected during motion.

Range: 1 – 250,000

DF – CW (direction forward)

Format: DF

Description: This command sets the rotation of the motor to clockwise. This can be done during motion to switch the motor direction “on-the-

fly” however motor will decelerate first depending on the deceleration setting before switching direction.

DR – CCW (direction reverse)

Format: DR

Description: This command sets the rotation of the motor counterclockwise. This can be done during motion to switch the motor direction “on-the-fly” however motor will decelerate first depending on the deceleration setting before switching direction.

EA – Encoder AC

Format: EA[0 or 1]

Description: This command enables the encoder autocorrect. This requires an encoder in order to function.

Range: 0 - 1

ED – Encoder delay

Format: ED[value]

Description: This command sets the encoder delay(ms). This is the amount of time before an encoder signal is read.

Range: 0 – 65,535

EH – Encoder Home

Format: EH[0 - 1]

Description: This command sets the startup bit to enable encoder homing on startup. This will automatically zero the encoder and motor shaft on startup by rotating the shaft until the encoder index is read.

Range: 0 – 1

EM – Encoder Motor Ratio

Format: EM[Value]

Description: This command changes the encoder motor ratio of the driver. See page 10 for calculation. (Accepts decimal point values up to 2 decimal points)

Range: 0.00 – 65525.00

EO – Encoder Revolutions

Format: EO[value]

Description: This command sets the encoder revolutions which is the number of revolutions the user wants the motor to rotate. Movement starts immediately after command is entered.

Range: 0 – 255

ER – Encoder retries

Format: ER[value]

Description: This command sets the amount of retries the encoder will perform to correct its position.

Range: 0 – 255

ET – Encoder reset

Format: ET[0 - 3]

Description: ET0: Reset encoder position to 0.
ET1: Reset encoder position and motor position to 0.
ET2: Home motor shaft to a known 0 position, then reset encoder position to 0. (Uses encoder index Ch. N)
ET3: Home motor shaft to a known 0 position, then reset encoder position and motor position to 0. (Uses encoder index Ch. N)

EW – Encoder window

Format: EW[value]

Description: This is the amount of “error” the encoder is allowed after a positional move to determine if the encoder reached a valid position.

Range: 0 – 255

EZ – Encoder Zero

Format: EZ[0 - 1]

Description: This toggles the encoder zero on startup feature to ensure, on startup, the encoder always reads zero.

Range: 0 - 1

FRH – Factory reset (Hard)

Format: FRH

Description: This command factory resets the device to default configurations.
Saved configurations will be lost.

FRS – Factory reset (Soft)

Format: FRS

Description: This command resets the current profile to default configurations.
Saved configurations will be kept.

GN – Go number of steps

Format: GN

Description: This command executes a move based on the number of steps the user has set with the “N” command.

GP – Go to position

Format: GP

Description: This command moves the motor to the position specified by the user with the “P” command.

H – Home

Format: H[value]

Description: H0: In type 0 homing, The MBC20SC1 will slew until the 0 position is reached.
H1: In type 1 homing, the MBC20SC1 will slew until a home limit is reached, ramp down to base speed, change directions and run at base speed unit the release of the home limit input.
H2 In type 2 homing, the MBC20SC1 will slew until a soft limit is reached, then ramp down to base speed. Motor will continue at base speed until a home limit is reached. The ramp profile is specified by the base speed, max speed, and acceleration/deceleration commands.

Range: 0 – 2

I – Index Program

Format: I[N,P,S,Z, .][value]

Description: This command allows the user to program the currently selected profile with the following commands: Go number of steps(N), Go to position(P), Slew(S), and Set Position(Z).

Command	Description
N[0 – 2 ³¹]	This programs the profile to perform a go number of steps move. Direction is based on the direction configuration.
P[±2 ³¹]	This programs the profile to perform a go to position move.
S[1 - 2]	This programs the profile to perform a Slew move in either 1: clockwise or 2: counterclockwise using the profiles ramp configurations.
Z[±2 ³¹]	This programs the profile to perform a set position operation.
.	This deletes the command from the profile.

L – Middle speed Thres.

Format: L[value]

Description: This is the middle speed threshold in which the motor will switch from base acceleration to max acceleration. When this is 0, only max acceleration and deceleration will be used.

Valid value: BS <= L <= MS

Range: 1 – 1,000,000

MA – Max acceleration

Format: MA[value]

Description: This is the max acceleration the motor will use to reach the max speed. This is active when speed is L >= Current speed <= MS.

Range: 0 – 65,535

MD – Max deceleration

Format: MD[value]

Description: This is the max deceleration the motor will use to slow down from max speed. This is active when speed is $L \geq \text{Current speed} \leq MS$.

Range: 0 – 65,535

MS – Max speed

Format: MS[value]

Description: This is the max speed that the driver will move the motor. This must be a higher value than base speed and mid speed.

Range: 1 - 2,000,000

N – Number of steps

Format: N[value]

Description: This sets the number of steps that the driver will move the motor.

Range: 0 – $(2^{31} - 1)$

P – Absolute position

Format: P[value]

Description: This is the position the user wants the motor to move to relative to its current position. It calculates the number of steps required to move to that position. The following formula is used for the calculation $N = P - Z$

Range: $\{-2^{31} \text{ to } 2^{31}\} - 1$

R – Reference config

Format: R[0 or 1]

Description: This configuration sets what the reference inputs do when grounded. They can be configured to be 0: Hard Stop or 1: Soft Stop.

Range: 0 - 1

S – Slew

Format: S

Description: This command slews the motor continuously with the current configurations.

SP – Select Profile

Format: SP[0 – 2]

Description: This command switches the unit to the desired profile. All configurations in the new profile will be loaded for use. Profiles 1 and 2 refer to Index 1 and 2 respectively.

SV – Save config

Format: SV

Description: This command saves the current driver configurations to the MBC20SC1's on-board memory. These configurations will be loaded on startup.

SVP – Save Profile

Format: SVP

Description: This command saves the current driver configurations to the current selected profile. This is saved onto the on-board memory of the unit.

T – Motor current (on/off)

Format: T[0 or 1]

Description: This command turns the motor 0: off or 1: on.

Range: 0 - 1

TA – Current adjust

Format: TA[value]

Description: This command sets the run current and hold current of the motor. Each unit of current is equal to ~0.066 mA.

Range: 0 – 31

TR – Run current adjust

Format: TR[value]

Description: This command sets the run current of the motor. Each unit of current is equal to ~0.066 mA.

Range: 0 – 31

TH – Hold current adjust

Format: TH[value]

Description: This command sets the hold current of the motor. Each unit of current is equal to ~0.066 mA.

Range: 0 – 31

V – Verify commands

Format: V[command]

Description: This allows the user to verify the value of the specified configuration. To verify a value, type 'V' followed by the command you want to verify. For example, "VMS" verifies max speed.

Command	Description	Command	Description
BA	Verify base acceleration	MD	Verify max deceleration
BD	Verify base deceleration	MS	Verify max speed
BS	Verify base speed	N	Verify number of steps
D	Verify Direction	P	Verify profile command
EA	Verify encoder autocorrect	R	Verify reference config
ED	Verify encoder delay	S	Verify startup bits
EM	Verify encoder motor ratio	T	Verify motor current
EO	Verify encoder revolutions	TH	Verify holding current
EP	Verify encoder position	TR	Verify running current
ER	Verify encoder retries	Z	Verify position
EW	Verify encoder window	/	Verify microstep division
L	Verify middle threshold	?	Verify profile selected
MA	Verify max acceleration		

Z – Position

Format: Z[value]

Description: This command changes the current position of the motor.

Range: $\{-2^{31} \text{ to } 2^{31}\} - 1$

. – Hard stop (Emergency Stop)

Format: .

Description: This command performs a hard stop on the motor.

, – Soft stop

Format: ,

Description: This command performs a soft stop on the motor.

/ – Microstep

Format: /[value]

Description: This command set the microstep division of the driver. (Valid divisions: 1, 2, 4, 8, 16, 32, 64, 128, 256)

Range: 1 - 256

\$ – Version

Format: \$

Description: This command displays the device name and version number.

~ – Address

Format: ~[value]

Description: This command changes the address of the device. Device must be saved for this change to take place.

Range: 0 - 99

Section 5: Troubleshooting

Problem:

Cannot establish communications with the MBC20SC1.

Possible Solutions:

- 1) Make sure the MBC20SC1 controller has power. Is the Green LED on?
- 2) Check the USB connections.
- 3) Check for loose cable connections either on the MBC20SC1 or USB port.
- 4) Was the software installed successfully?
- 5) Go to **Setup | Com Port Settings** and verify COM port and baud rate settings.
- 6) Go to **Setup | Axis** and verify address settings are the same.
- 7) Click on **Setup | Connect** icon to communicate with the MBC20SC1.
- 8) If problems still exist, contact Anaheim Automation Tech Support.

Anaheim Automation, Inc,
Tech Support:

4985 E Landon Drive
Anaheim, CA 92807
Phone: (714) 992-6990
Fax: (714)992-0471
www.anaheimautomation.com

Problem:

There is no power to the MBC20SC1 controller.

Possible Solutions:

- 1) Is the MBC20SC1 controller connected to the appropriate power supply?
- 2) Check for any blown fuses in line with the MBC20SC1 controller.
- 3) If problems still exist, contact Anaheim Automation. Inc. Tech Support.

Problem:

The MBC20SC1 is not saving configurations.

Possible Solutions:

- 1) Check USB Connections.
- 2) Check for loose cable connections either on the MBC20SC1 or USB port.
- 3) After changing the configurations, Go to **Options | Save Current Configuration** and verify in the **Log** tab that the configuration has been saved.
- 4) If problems still exist, contact Anaheim Automation, Inc. Tech Support.

Problem:

The MBC20SC1 unit will not “autostart”.

Possible Solutions:

- 1) Go to **Options | Autostart** and verify that autostart is switched on.
- 2) Make sure after switching on autostart, to save the current configuration.
- 3) If Problems still exist, contact Anaheim Automation, Inc. Tech Support.

Problem:

The MBC20SC1 will not run after hard stop.

Possible Solutions:

- 1) “Hard stop” the MBC20SC1 and then try toggling the on/off (motor current) of the MBC20SC1.
 - a. This is an error latch to protect the unit after a difficult stop.
- 2) Power cycle the MBC20SC1 controller.
 - a. Make sure to save the current configuration to avoid losing any progress.

Appendix 1: ASCII Table for Direct Mode

ASCII Symbol	Hex Value	ASCII Symbol	Hex Value	ASCII Symbol	Hex Value
0	30	J	4A	#	23
1	31	K	4B	\$	24
2	32	L	4C	%	25
3	33	M	4D	"	27
4	34	N	4E	(28
5	35	O	4F	+	2B
6	36	P	50	,	2C
7	37	Q	51	-	2D
8	38	R	52	.	2E
9	39	S	53	:	3A
A	41	T	54	;	3B
B	42	U	55	@	40
C	43	V	56	[5B
D	44	W	57]	5D
E	45	X	58	^	5E
F	46	Y	59	{	7B
G	47	Z	5A	}	7D
H	48	Carriage Return	0D	~	7E
I	49	!	21		

Appendix 2: Firmware Revisions

Version 1.00 - Initial Release.

Copyright

Copyright 2026 by Anaheim Automation, Inc.. All rights reserved. No part of this publication may be reproduced, transmitted, transcribed, stored in a retrieval system, or translated into any language, in any form or by any means, electronic, mechanical, magnetic, optical, chemical, manual, or otherwise, without the prior written permission of Anaheim Automation, Inc., 4985 E Landon Drive, Anaheim, CA 92807. The only exception to this would be use of the program examples in this manual.

Disclaimer

Though every effort has been made to supply complete and accurate information in this manual, the contents are subject to change without notice or obligation to inform the buyer. In no event will Anaheim Automation, Inc. be liable for direct, indirect, special, incidental, or consequential damages arising out of the use or inability to use the product or documentation.

Limited Warranty

All Anaheim Automation, Inc. products are warranted against defects in workmanship, materials and construction, when used under Normal Operating Conditions and when used in accordance with specifications. This warranty shall be in effect for a period of twelve months from the date of purchase or eighteen months from the date of manufacture, whichever comes first. Warranty provisions may be voided if the products are subjected to physical damage or abuse.

Anaheim Automation, Inc. will repair or replace at its option, any of its products which have been found to be defective and are within the warranty period, provided that the item is shipped freight prepaid, with RMA (return material authorization), to Anaheim Automation's plant in Anaheim, California.

Trademarks

Control Link and Driver Pack are registered trademarks of Anaheim Automation, Inc.

IBM PC is a registered trademark of International Business Machines, Inc.