

# LS500 Series Positioning Tables

## User's Guide

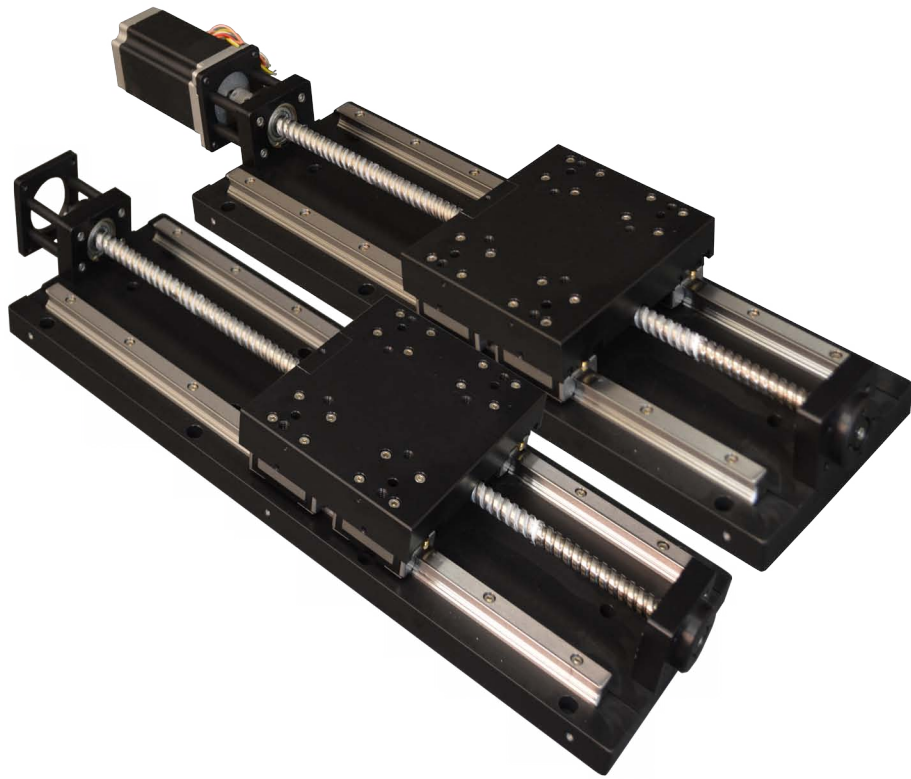

L011227



**ANAHEIM AUTOMATION**

4985 East Landon Drive Anaheim, CA 92807  
e-mail: [info@anaheimautomation.com](mailto:info@anaheimautomation.com)

(714) 992-6990 fax: (714) 992-0471  
website: [www.anaheimautomation.com](http://www.anaheimautomation.com)

## LS500 Series Positioning Table Features and Applications

- Lab Automation
- Biotech Automation
- Inspection Stations
- Part Scanning
- Pick & Place
- Liquid Dispensing
- Part Insertion

### Construction

The LS500 Series is a Linear Stage comprised of heavy duty linear guides with hardened rails and precision bearing blocks, a precision ground screw, and a zero-backlash nut. This series is ideal for medium to heavy-duty applications up to 150 pounds, with accuracy requirements within 0.003 inches per foot, and speed ranges up to 25 inches per second. The LS500 series is an economical package with a low-cost base price (includes a 12 inch travel, no options selected). The LS500 series is available with either open-loop or closed-loop control (assembled with an encoder), homing and end limit switch options, as well as a variety of lead screw, stepper motor, and encoder choices, with travel lengths up to 18 inches. Should your application require a larger load, contact an applications engineer to discuss customization options. American Made - designed and built in the USA!

### Ball Screws

Each positioning table utilizes its own unique ball screw. This ball screw is chosen for its high precision for the dimensions of the table. The system uses a steel ball screw with a plastic nut for travel.

Screw Option	Screw Type and Size	Linear Distance per Revolution (inches)	Travel Accuracy (in/ft)	Resolution per 1/2 Step (inches)	Torque to Raise 1 lb	Bidirectional Repeatability (inches)
LS 500 Screw	1/2-4, 2 Start Ball Screw	0.5	0.0003	0.00125	1.91 oz-in	0.001



## End of Travel and Home Switches (Optional)

The LS500 series tables can be provided with end of travel (EOT) and home proximity switches, which are assembled / wired onto the table assembly. Most position controllers can utilize the EOT switches to stop the carriage motion when exceeding table travel has been reached in either direction. The home switch provides a known datum location or zero position on the table that establishes a known HOME position for the positioning controller used.

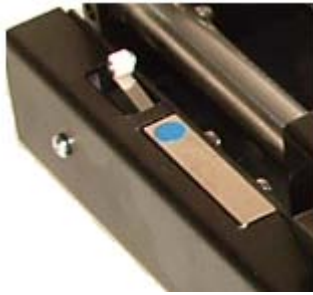

## Rotary Encoders (Optional)

Incremental encoders can be mounted to the step motors in order to provide position and speed feedback data to a motion controller.

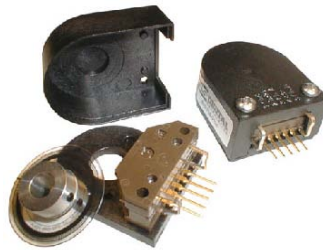

## Mounting Requirements

The LS500 provides mounting holes for direct mounting onto the carriage of the table. These mounting holes are designed for simple mounting for a multi-axis system. In order to achieve the published accuracy and repeatability of an LS500 Series Positioning Table, care must be taken when mounting the table to your surface. The mounting surface of the positioning table must be as flat, or flatter than the positioning table itself. If the surface is not flat, shimming may be required. Proper table mounting is essential and highly recommended so that the table can be supported over its entire length and that all table base mounting holes are used. This will prevent the table from deflecting over unsupported regions when the load travels over that area. It also maintains the systems rigidity, and prevents shortened positioning table life from structural fatigue.

**Recommended Base Mounting Screws: English mount #10-32**  
**Base Mounting screws are not provided by Anaheim Automation**

## Cantilever Load

It is recommended that a 1:1 ratio be used when loading the carriage of the LS500 Series Tables. The Carriage Length predetermines the attached MAX Length that the extended load should rest from.

## Motor Adapter Brackets

The NEMA 23 is the Standard motor mount for all LS500 Series Tables. Each Table comes with a flexible coupling and four 10-32 mounting screws. ( For no motor option, no coupling or mounting screws are included)

## Maximum Carriage Speed

The maximum speed of the carriage is determined by the ball screw lead, screw length, screw diameter and bearing support system. *Refer to Specifications section for more details.*

## Backlash

The drive nut offered is a pre-loaded, zero backlash nut offering zero backlash operation that automatically adjusts for wear to insure zero backlash for the life of the positioning table.

## Linear Guide Rails

The linear guides used are CPC-ARC15MNBZV0N linear guides with a 15 mm block width designed to provide high precision and support high loads.



## Connections to Table Assembly

Separate cables with mating connectors for the step motor, EOT/ Home Limit Switches, and encoder are provided (if option is selected) for ease of operation.



## Lubrication

The type of lubrication recommended is TriGel 300s, Lithium Grease or Synthetic Teflon Grease. It is recommended that the linear rails and screw assembly be lubricated depending on the application duty, speed, and environment installed. Insufficient lubrication can result in excessive wear which may cause scoring of the rails, rough table operation, corrosion, and even failure of the positioning system. **WARNING:** Avoid the use of WD-40, or cleaning solvents, as they can cause damage to the screw assembly and linear rails. Ball screw and polymer nut screw driven positioning tables have a solid surface contacting a solid surface, therefore sufficient lubrication is required. Apply lubrication directly onto the entire length of the screw and linear rails on a regular basis.

The critical factor in the life of a plastic nut is the heat build up in the nut. Each application has different heat conditions as well as differences in lubrication requirements. These have a dramatic effect on the nut life.

# Dimensions

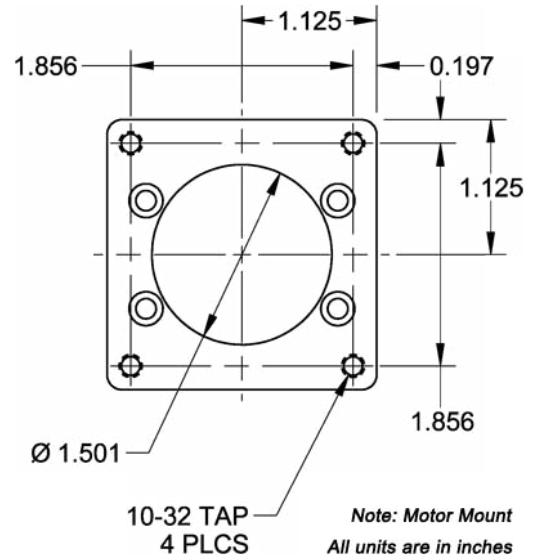
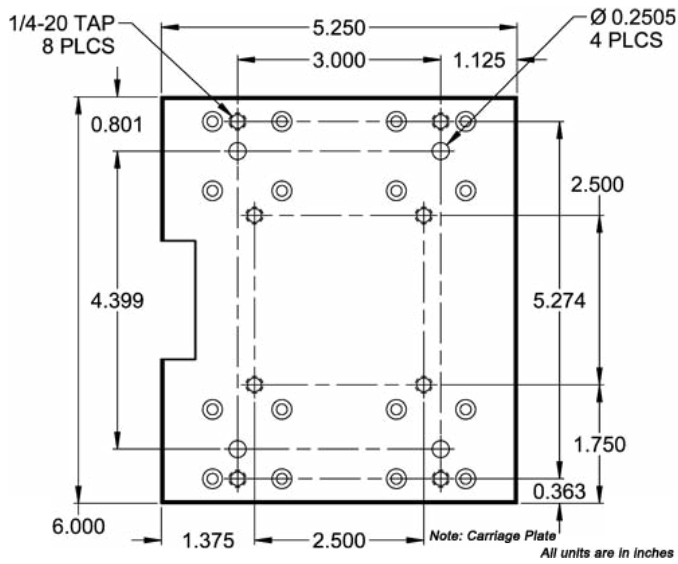
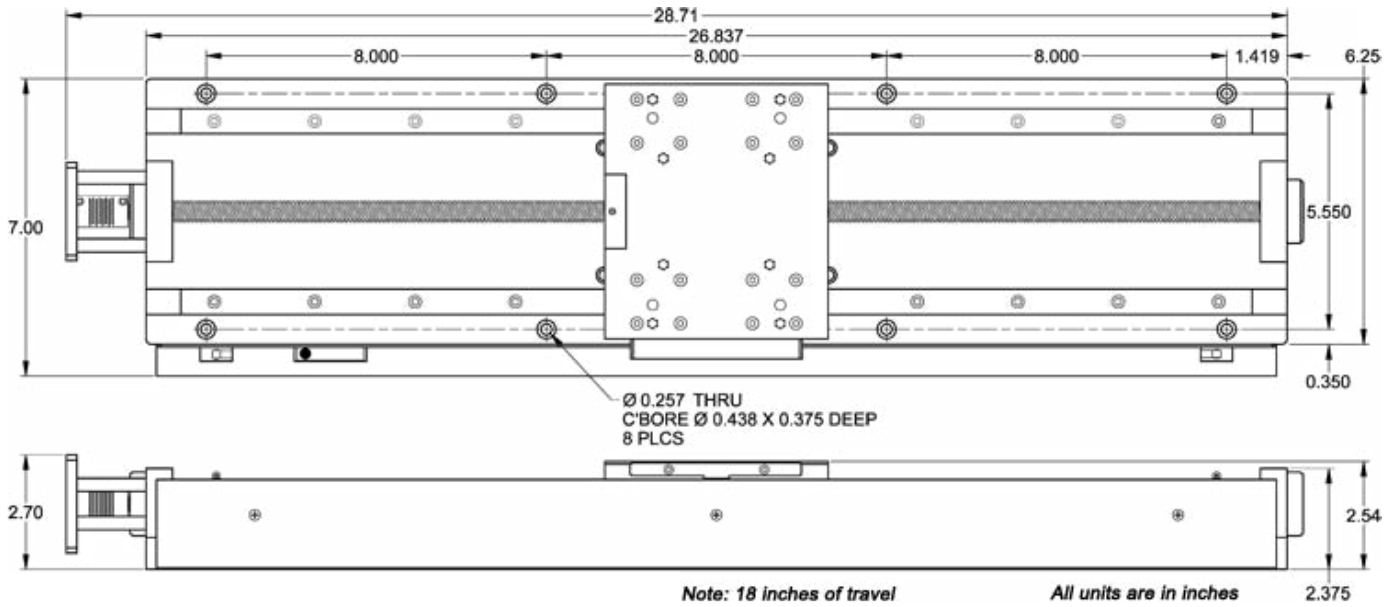

*The area below 1500 pounds and less than 2000RPM is the recommended load region.*

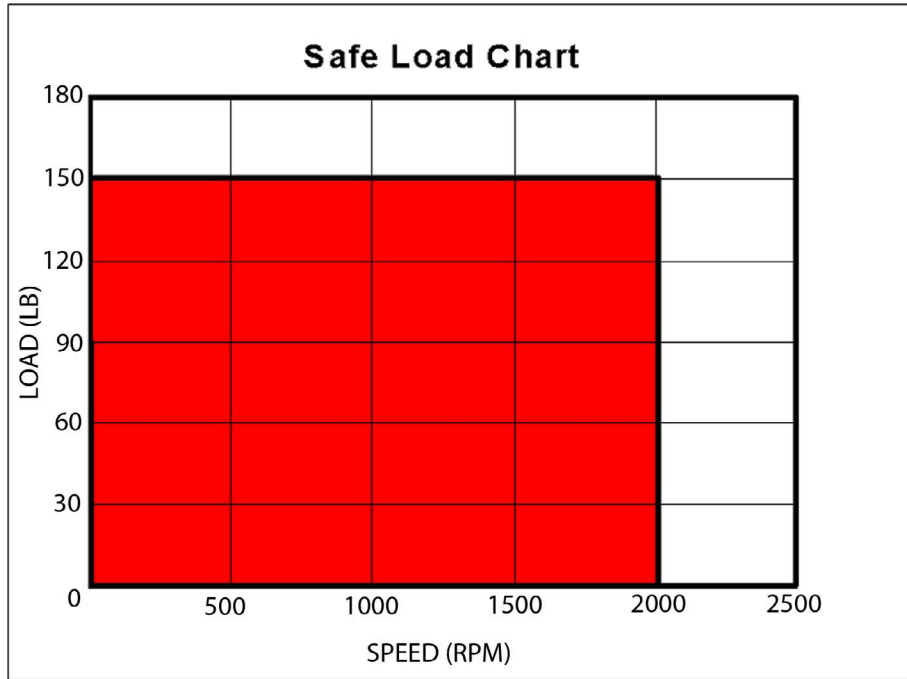

## Limits

Note: All models with limit switches come with a 6 conductor cable and a mating Mini-Fit Jr. connector.

Limits/Sensor Cable - CBL-AA4101-10		
Connector PIN#	Color	Function
1	Brown	Home Switch Power In (10-30VDC 200mA)
2	Red	Home Switch
3	Green	0VDC, Common
4	Blue	Limit Switch Hard -
5	White	Limit Switch Hard +

## Home Switch Electrical Diagram

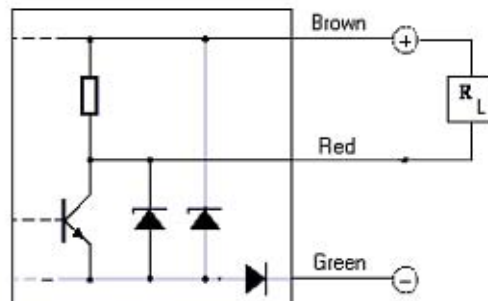

# Specifications

	Travel	12"	18"
Load Capacity	Static	750 lbs (204kg)	
	Dynamic	150 lbs (68.04 kg)	
Inertia	50 lbs (22.68kg)	0.546 lb-in <sup>2</sup>	0.558 lb-in <sup>2</sup>
	100 lbs (45.36kg)	1.057 lb-in <sup>2</sup>	1.069 lb-in <sup>2</sup>
Stage Weight (Without Motor)	Without Limit Switches	17.36lb (7.87kg)	22.04lb (10kg)
	With Limit Switches	18.16lb (8.24kg)	23.04lb (10.45kg)
Resolution with Divide-by-64	0.5 in/rev lead (12.7 mm/rev) 39.1 x 10 <sup>-6</sup> Inches (0.99µm) @ 12,800 steps/rev resolution		
Resolution with 400 Line Encoder	0.5 in/rev lead (12.7 mm/rev) 3.12 x 10 <sup>-4</sup> Inches (7.93µm) @ 1,600 steps/rev resolution		
Resolution with 1000 Line Encoder	0.5 in/rev lead (12.7 mm/rev) 1.25 x 10 <sup>-4</sup> Inches (3.18µm) @ 4,000 steps/rev resolution		
Encoder Outputs	---	TTL Square Wave, Two Channel A & B	
Maximum Travel Speed	25 Inches/Second (635mm/sec)		
Repeatability Bidirectional	Leadscrew	<0.001 Inches (25.4µm)	
Material	---	Aluminum	
Finish	---	Black Anodize	
Flatness, Straightness, & Orthogonality	---	<0.001 [Inch/Inch] (<25.4µm/µm)	
Screw Material	---	Stainless Steel	
Nut Efficiency	---	75%	
Nut Temperature	---	32°F-180°F (0°C-82°C)	
Nut-Screw Friction Coefficient	---	0.08-0.14	
Duty Cycle	---	Low to Mid (<50%)	

## Motors Only (23Y) Specifications:

Note: All Motor options come with an 8 Pin Molex Mini-Fit Jr. connector and a 10ft, 8 wire conductor cable with mating Molex Mini-Fit Jr. connector.

Motor Option	Motor Part Number	Bipolar Torque (oz-in)	Series Current (A)	Unipolar Current (A)	Parallel Current (A)	Unipolar Inductance (mH)	Rotor Inertia (oz-in-sec <sup>2</sup> )	Weight (lbs)	"L" Length (in)
<b>3A</b>	23Y006S-LW8	76	2.10	3.0	4.2	0.6	0.0017	1.00	1.62
<b>3B</b>	23Y106S-LW8	175	2.10	3.0	4.2	1.1	0.0042	1.55	2.21
<b>3C</b>	23Y206S-LW8	262	2.10	3.0	4.2	1.6	0.0068	2.21	3.00
<b>3E</b>	23Y006D-LW8	76	2.10	3.0	4.2	0.6	0.0017	1.00	1.62
<b>3F</b>	23Y106D-LW8	175	2.10	3.0	4.2	1.1	0.0042	1.55	2.21
<b>3G</b>	23Y206D-LW8	262	2.10	3.0	4.2	1.6	0.0068	2.21	3.00

Step Angle Accuracy:	± 5% (Full Step, No Load)	Insulation Resistance:	100M Ohm Min, 500VDC
Resistance Accuracy:	± 10%	Dielectric Strength:	500VAC for 1 minute
Inductance Accuracy:	± 20%	Shaft Radial Play:	0.02" Max (1.0 lbs)
Temperature Rise:	80°C Max (2 Phases On)	End Play:	0.08" Max (1.0 lbs)
Ambient Temperature:	-20° to +50° C	Max Radial Force:	16.9 lbs (0.79" from Flange)
Insulation Type:	Class B	Max Axial Force:	3.4 lbs-Force

Motor Cable - CBL-AA4102-10		
Connector Pin #	Color	Function
1	Black	Phase A
2	Black/White	Phase A\
3	Orange/White	Phase C\
4	Orange	Phase C
5	Red	Phase B
6	Red/White	Phase B\
7	Yellow/White	Phase D\
8	Yellow	Phase D

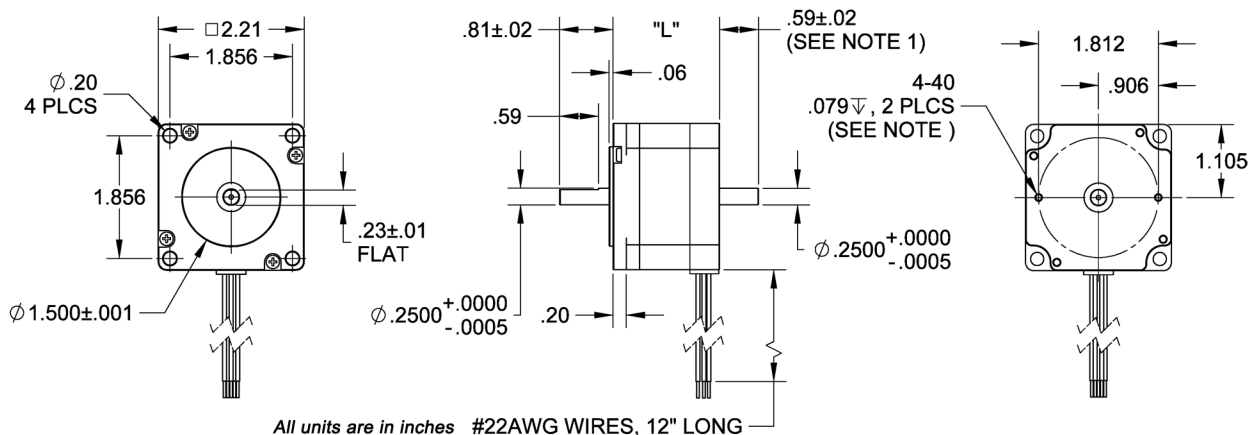
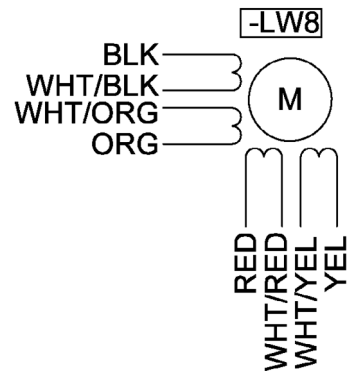

NOTE 1: 23YxxxD-LW8 Models Only



## Motors with Integrated Drivers (23MD) Specifications:

Note: All Motors with Integrated Drivers options come with a 10ft, 7 conductor cable with mating 7 pin MTA connector.

Motor Option	Motor Part Number	Bipolar Torque (oz-in)	Rotor Inertia (oz-in-sec <sup>2</sup> )	Weight (lbs)	"L" Length (in)	Active Input
4G	23MD006S-00	76	0.0017	1.20	2.98	Sinking
4H	23MD006S-24	76	0.0017	1.20	2.98	Sourcing
4E	23MD106S-00	175	0.0042	1.75	4.03	Sinking
4F	23MD106S-24	175	0.0042	1.75	4.03	Sourcing
4I	23MD206S-00	262	0.0068	2.41	4.94	Sinking
4J	23MD206S-24	262	0.0068	2.41	4.94	Sourcing
4M	23MD006D-00	76	0.0017	1.20	2.98	Sinking
4N	23MD006D-24	76	0.0017	1.20	2.98	Sourcing
4K	23MD106D-00	175	0.0042	1.75	4.03	Sinking
4L	23MD106D-24	175	0.0042	1.75	4.03	Sourcing
4O	23MD206D-00	262	0.0068	2.41	4.94	Sinking
4P	23MD206D-24	262	0.0068	2.41	4.94	Sourcing

Power Requirements:	12-24VDC	Microstepping Res.	1600 Steps/Rev (Div-by 8)
Input Voltage (Inputs):	3.5 - 24VDC	Driver Type:	Bipolar Series
Step Angle Accuracy:	+/- 5% (Full Step, No Load)	Insulation Resistance:	100M Ohm Min, 500VDC
Temperature Rise:	80°C Max (2 Phases On)	Dielectric Strength:	500VDC for One Minute
Ambient Temperature:	-20° to +50° C	Radial Play:	0.02" at 1.0 lbs
Insulation Type:	Class B	End Play:	0.08" at 1.0 lbs
Max Axial Force:	3.4 lbs-Force	Max Radial Force:	16.9 lbs (0.79" from Flange)

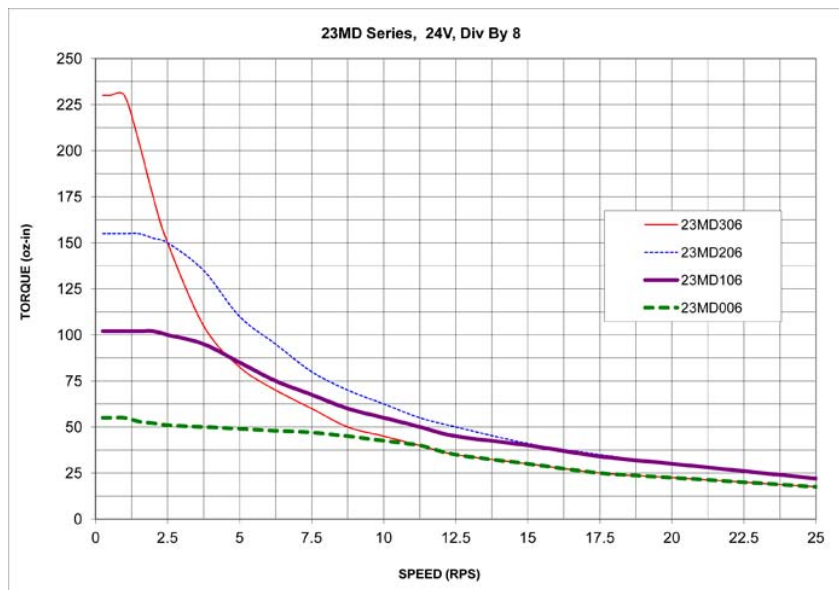

# Motors with Integrated Drivers (23MD) Specifications: (Cont.)

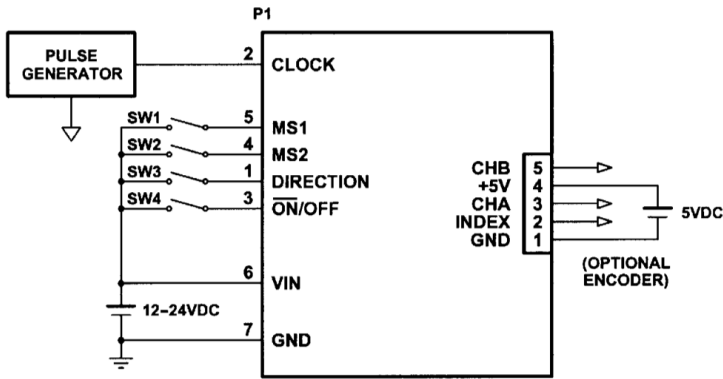

**23MD SERIES  
(SOURCING INPUTS)**

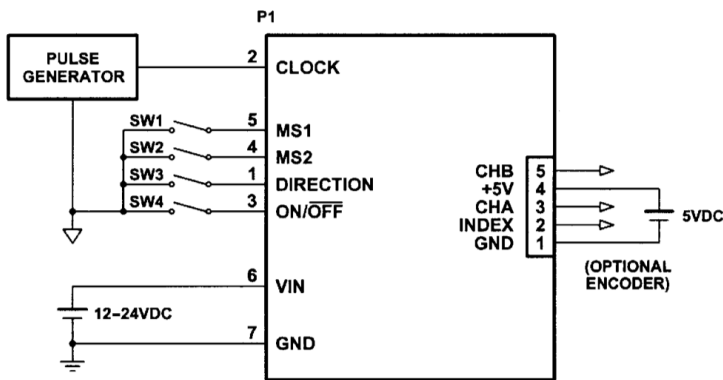

**23MD SERIES  
(SINKING INPUTS)**

23MD Input Cable - CBL-AA4266		
Connector Pin #	Color	Function
1	Brown	Direction
2	Red	Clock
3	Orange	On/Off
4	Yellow	MS2
5	Green	MS1
6	Blue	12VDC-24VDC
7	Violet	0VDC (Gnd)

Microstep Resolution Truth Table		
MS1	MS2	Resolution
Active	Active	Full Step
Inactive (Open)	Active	Half Step
Active	Inactive (Open)	Quarter Step
Inactive (Open)	Inactive (Open)	Eighth Step

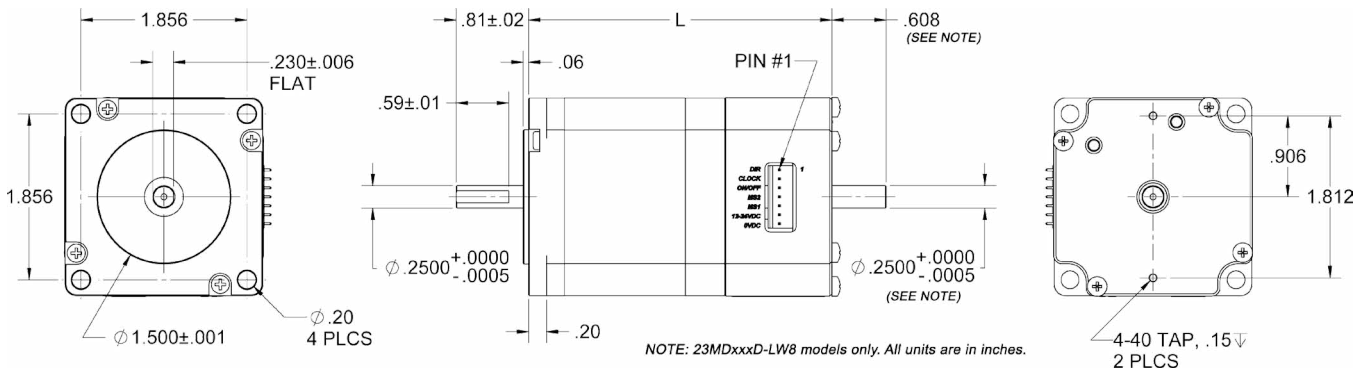

# Motors with Integrated Controllers and Drivers (23MDSI) Specifications:

Note: No cable is provided with the Motors with Integrated Controllers and Drivers option.

Motor Option	Motor Part Number	Bipolar Torque (oz-in)	Rotor Inertia (oz-in-sec <sup>2</sup> )	Weight (lbs)	L Length (in)
5E	23MDSI106S-00-00	175	0.0042	1.73	3.504
5I	23MDSI206S-00-00	262	0.0068	2.39	4.292
5K	23MDSI106D-00-00	175	0.0042	1.73	3.504
5O	23MDSI206D-00-00	262	0.0068	2.39	4.292

Power Requirements:	12-24VDC	Microstepping Res.	1600 steps/rev (Div-by 8)
Input Voltage (Inputs):	3.5 - 24VDC	Driver Type:	Bipolar Series
Step Angle Accuracy:	+/- 5% (Full Step, No Load)	Insulation Resistance:	100M Ohm Min, 500VDC
Temperature Rise:	80°C Max (2 Phases On)	Dielectric Strength:	500VDC for One Minute
Ambient Temperature:	-20° to +50° C	Radial Play:	0.02" at 1.0 lbs
Insulation Type:	Class B	End Play:	0.08" at 1.0 lbs
Max Axial Force:	3.4 lbs-Force	Max Radial Force:	16.9 lbs (0.79" from Flange)

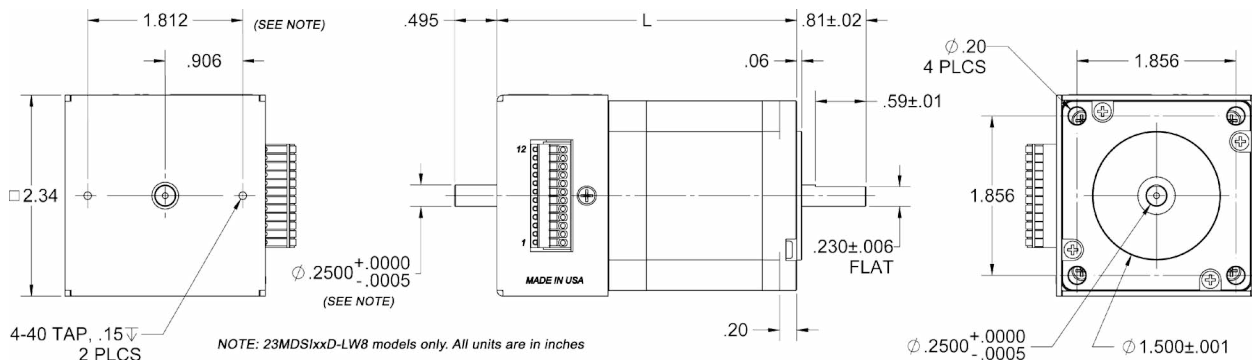
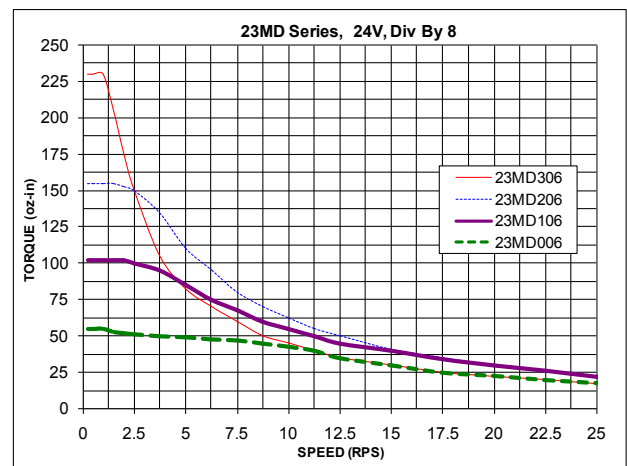
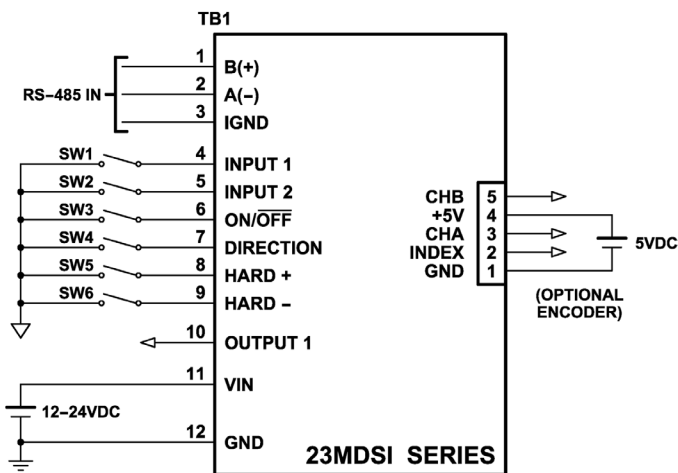

Note: 23MDSIxxxD-LW8 models only. All units are in inches.

## Encoder Cable Connection

Note: All models with encoders come with a 10 ft, 4 wire conductor cable and a mating 5 Pin MTA connector.

Encoder Cable - CBL-AA4175-10		
Connector PIN #	Color	Function
1	Black	0VDC
2	N/C	---
3	Orange	CH A
4	Red	+5Vdc
5	Yellow	CH B

Parameter	Min	Typ	Max	Units
<b>Supply Current</b>				
CPR < 500, no load	-	27	30	mA
CPR ≥ 500, no load	-	55	57	mA
<b>Output Low</b> ( $I_{OL} = 8\text{mA max}$ )	-	-	0.5	Volts
<b>Output High*</b>				
$I_{OL} = -8\text{mA max}$	2.0	-	-	Volts
no load	4.2	4.8	-	Volts
<b>Output Current Per Channel</b>	-8.0	-	8.0	mA
<b>Output Rise Time</b>		110		nS
<b>Output Fall Time</b>		35		nS

\* Unloaded high level output voltage is 4.80V typically, 4.2V minimum.

Recommended Operating Conditions	Min	Max	Units
Temperature	-40	100	°C
Supply Voltage	4.5	5.5	Volts
Load Capacitance	-	100	pF
Count Frequency	-	100	kHz

Parameter	Description
CPR(N):	The Number of Cycles Per Revolution
One Shaft Rotation:	360 mechanical degrees, N cycles
One Electrical Degree (°e):	1/360th of one cycle
One Cycle (C):	360 electrical degrees (°e). Each cycle can be decoded into 1 or 4 codes, referred to as X1 or X4 resolution multiplication
Symmetry:	A measure of the relationship between (X) and (Y) in electrical degrees, nominally 180°e
Quadrature (Z):	The phase lag or lead between channels A and B in electrical degrees, nominally 90°e
Index (CH I):	The Index Output goes high once per revolution, coincident with the low states of channels A and B, nominally 1/4 of one cycle (90°e)

Parameter	Max	Units
Vibration (5 to 2kHz)	20	g
Shaft Axial Play	+/- 0.01	in.
Shaft Eccentricity Plus Radial Play	0.004	in.
Acceleration	250,000	rad/sec <sup>2</sup>

Timing Characteristics	Symbol	Min	Typ	Max	Units
Cycle Error	C	-	3.0	5.5	°e
Symmetry	X,Y	150	180	210	°e
Quadrature	Z	60	90	120	°e
Index Pulse Width	Po	60	90	120	°e
Ch. I Rise After Ch. B or Ch. A Fall	t1	10	100	250	ns
Ch. I Fall After Ch. B or Ch. A Rise	t2	70	150	300	ns

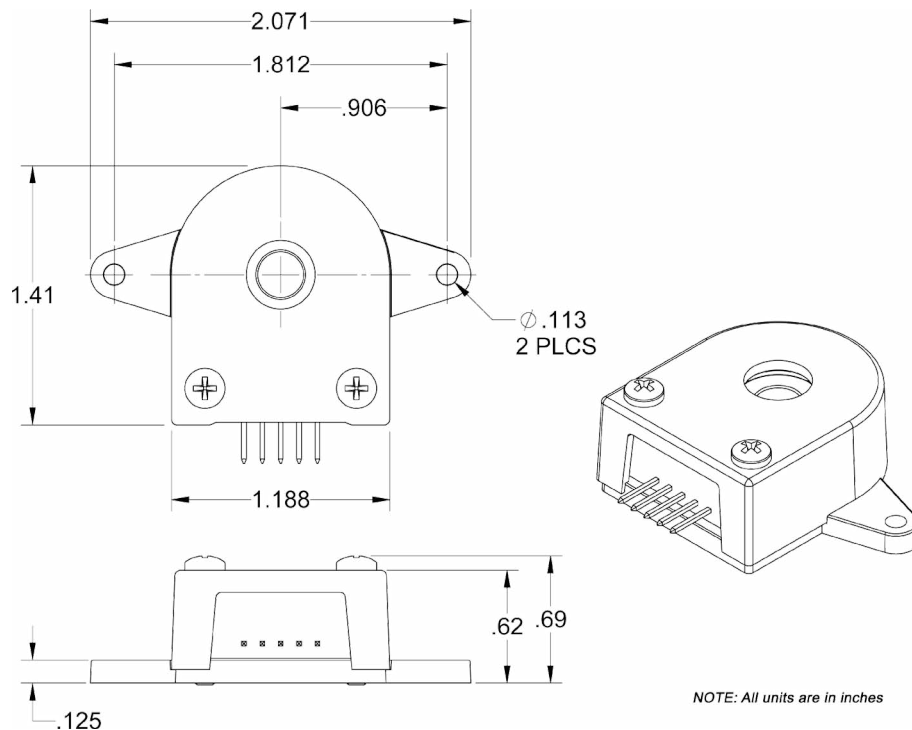

### Brake Option

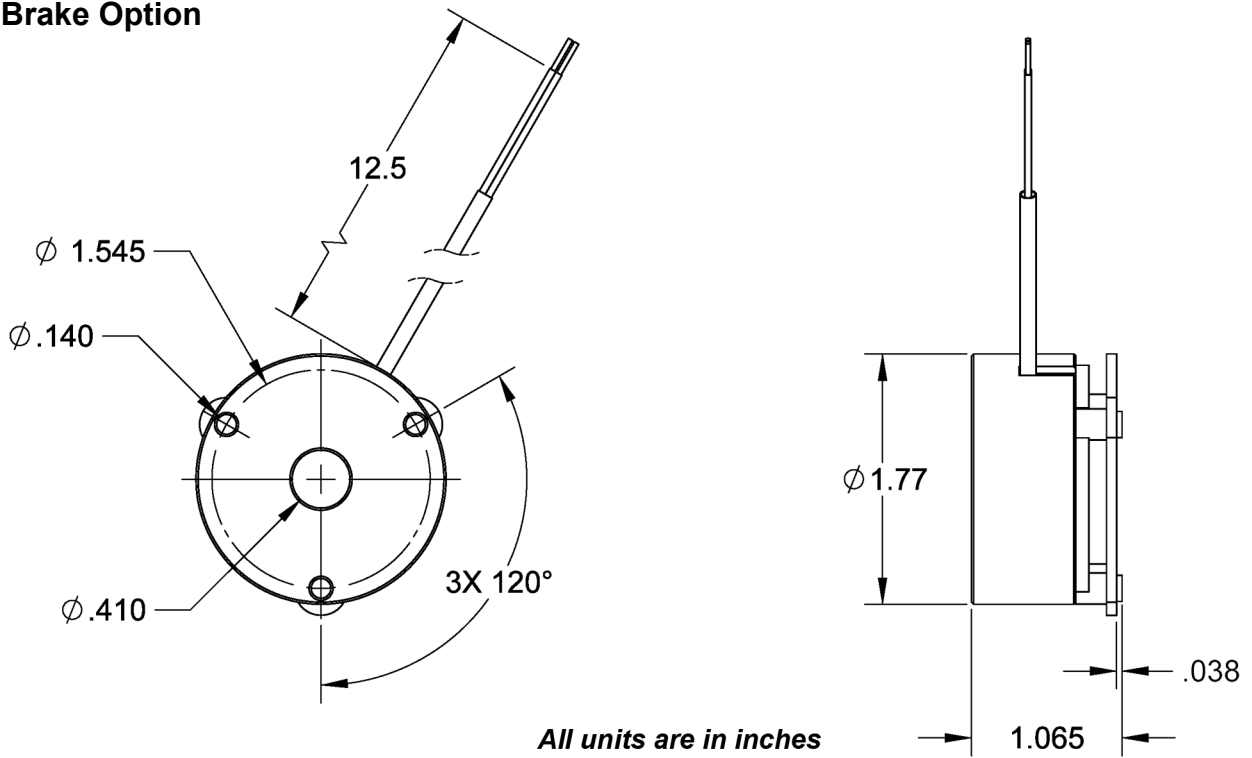

### Brake Attached to NEMA 23 Frame Motor

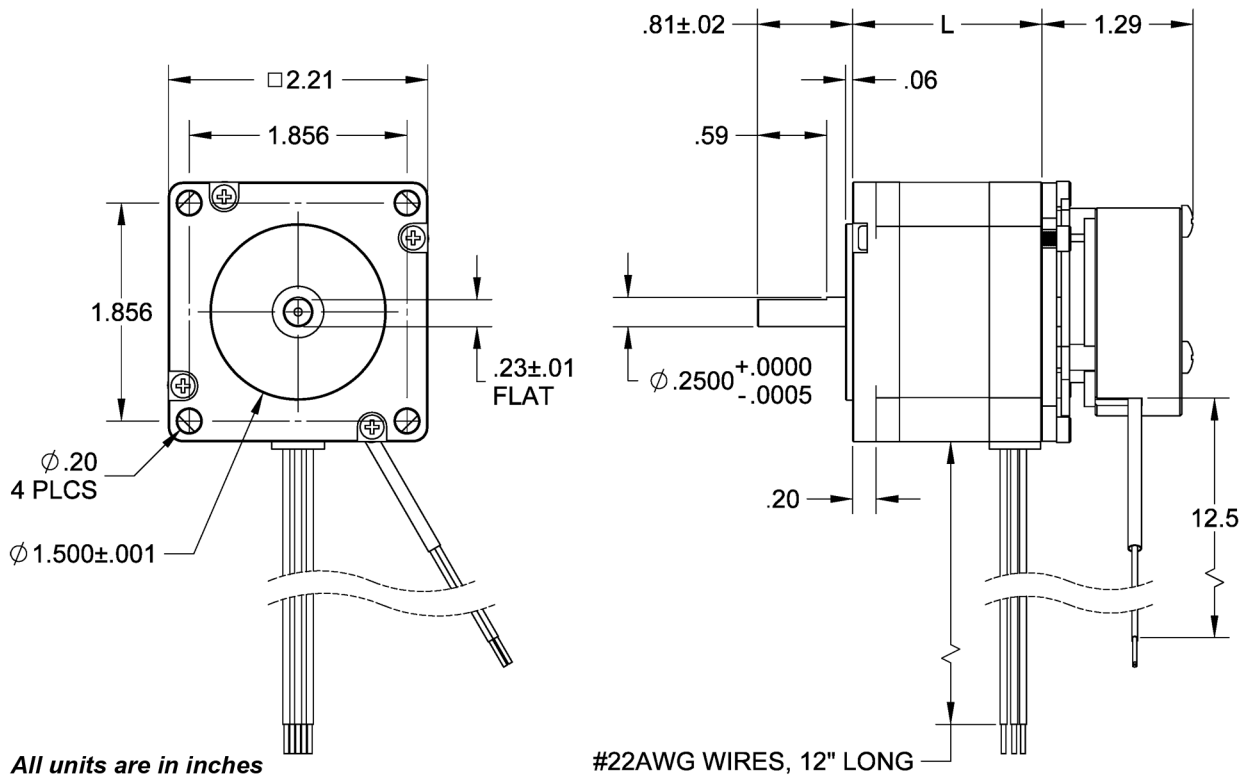

Model #	Fits NEMA Size	Bore Size (in)	Maximum Torque (oz-in)	Maximum Torque (in-lb)	Electric Power (Watts)	Current (mA)	Voltage (V)	Diameter (in)	Width (in)	Weight (lbs)
BRK-12H-80-024-197	23	0.197	80	5	7	375	24	1.77	0.890	0.38
BRK-12H-80-024-250	23	0.250	80	5	7	375	24	1.77	0.890	0.38

# Part Number Creation Guide

# LS500 - 12 - H - N - 3A - N

Series	Travel Options		Screw Options		Limit Options		Encoder/Brake Options	
	12	12"	H	.500"	N	No Limits	N	No Brake or Encoder
	18	18"			S	End of Travel	B	400 Line Encoder
					B	End of Travel & Home Prox.	C	1000 Line Encoder
							K	80 oz-in Brake

- All Tables Assembled with a Zero Backlash Nut
- All Tables Include a 10ft Motor Cable
- All Tables with Limits Include a 10ft Limit Cable
- All Tables with Encoders Include a 10ft Encoder Cable
- Custom Options Available, Contact Factory for Details

Accessories	
LS500-XY-KIT	Mounting Hardware for XY Configuration

Motor Options		
00		No Motor
Motors Only		
SS	DS	Motor Type
3A	3E	Size 23, 1/2 Stack, 3A
3B	3F	Size 23, 1 Stack, 3A
3C	3G	Size 23, 2 Stack, 3A
3P	3Q	Size 24, 5 Stack, 4A
Motors with Integrated Driver (All Motor/Drives are Size 23)		
SS	DS	Motor Type
4G	4M	1/2 Stack, Sinking
4H	4N	1/2 Stack, Sourcing
4E	4K	1 Stack, Sinking
4F	4L	1Stack, Sourcing
4I	4O	2 Stack, Sinking
4J	4P	2 Stack, Sourcing
Motors with Integrated Controller and Driver (All Motor/Driver/Controllers are Size 23)		
5E	5K	1 Stack
5I	5O	2 Stack
*SS=Single Shaft, DS=Dual Shaft		

# XY Mounting Assembly Schematic

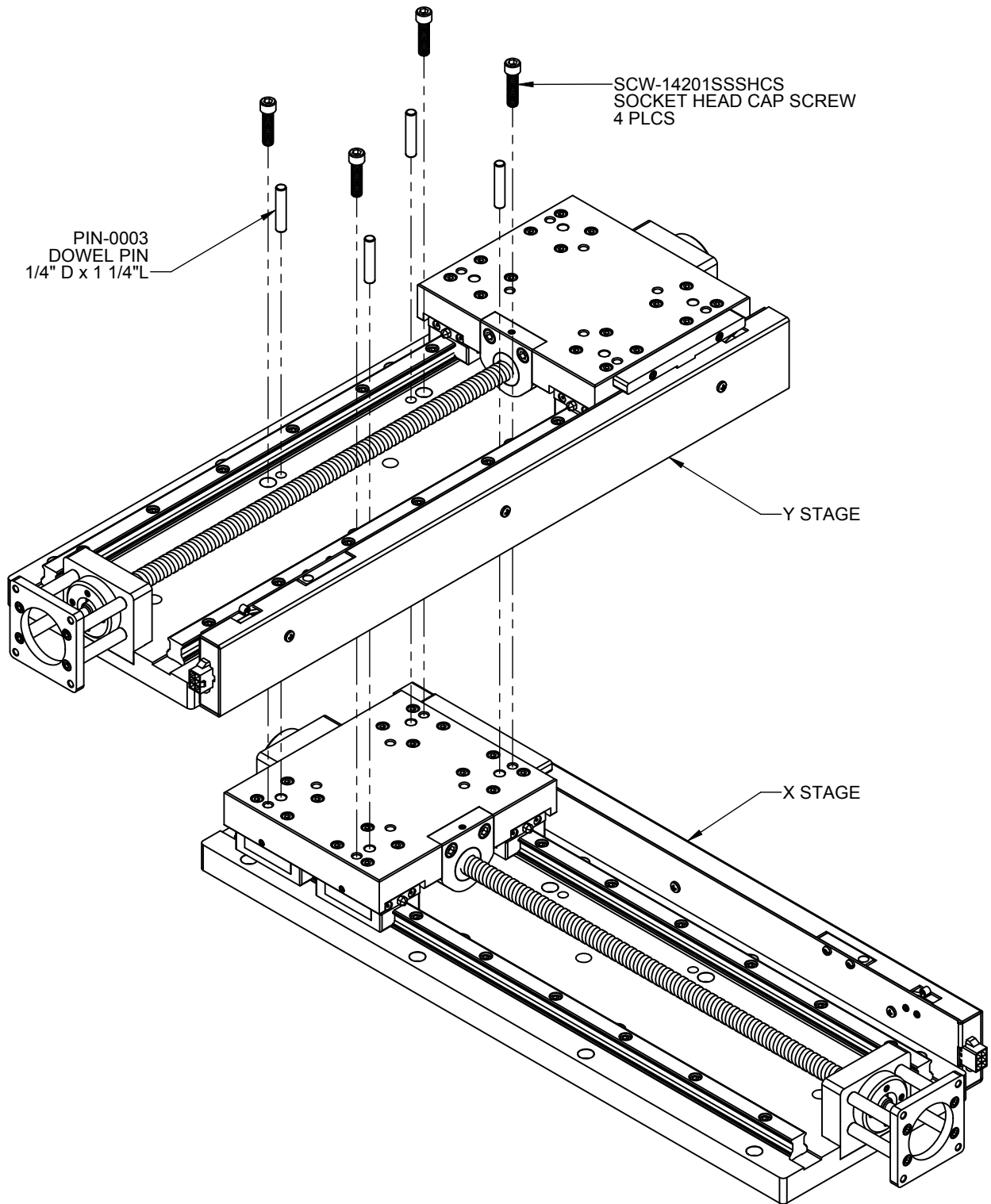

## **Terms and Conditions**

### **Limited Warranty**

All Anaheim Automation products are warranted against defects in workmanship and materials, when used under normal operating conditions and when used in accordance with the factory's specifications. This warranty is in effect for a period of twelve months from the date of purchase, or eighteen months from the date of manufacture, whichever comes first. Anaheim Automation will repair or replace at its' option, any of its products found to be defective and are within the warranty period. Anaheim Automation is not responsible for removal, installation, or incidental expenses incurred in shipping to and from the factory. Anaheim Automation is not liable, under any circumstances, for any consequential, incidental or indirect damages or expenses associated with the warranted product. Product that is damaged due to misuse, abuse, negligence, exposure, accident, improper installation or hook-up, or has been modified or dismantled, is NOT covered under this warranty.

### **Open Accounts**

Anaheim Automation extends credit to Government agencies, industrial and distributor accounts with a good published credit rating. Companies may apply for an open account by filling out Anaheim Automation's Credit Application Form, or by supplying credit information on their company's letterhead to Anaheim Automation's Accounting Department. Credit Information supplied by the buyer, or by others on the customer's behalf, shall become part of the Credit Application and any false or misleading information shall constitute fraud. All orders are shipped prepaid, COD, cash, wire-transfer, VISA or Mastercard, until an open account is established.

### **Payment Terms for Open Accounts**

Terms are Net 30 days. FOB is Anaheim, California.

### **Account Management and Remedies**

In the event it becomes necessary for Anaheim Automation to file suit to enforce payment of past due invoices, such a suit will be brought in Orange County, California. Anaheim Automation shall be entitled to collection of fees, court costs, and interest at 10% per annum or such legal maximum rate as is allowed, on all invoice amounts past due. All purchase agreements are governed by the laws of the State of California.

### **Shipping**

Anaheim Automation ships UPS Ground. If the customer prefers another carrier, or a premium routing method, this information must be clearly stated on the Purchase Order and confirmed, in writing, by Anaheim Automation. The customer must authorize any additional expenses that will incur. If quoted "factory stock," and Anaheim Automation has received a Purchase Order by noon PST, the order will ship the following day. For customers with an urgent request, there exists a possibility to ship later the same day. However, an "expedite fee" is charged, along with any other expenses incurred to fulfill this request.

All promises of shipment or delivery are approximated as closely as possible by Anaheim Automation, but are subject to delivery estimates made by our suppliers, weather conditions, fires, strikes, disputes, accidents, delays in transportation, material, fuel, or labor shortages, or any other cause beyond reasonable control of Anaheim Automation. *In no event will Anaheim Automation assume any responsibility for any delays in shipments or deliveries.*



### **Blanket Orders**

All Blanket Orders must be confirmed with a written Purchase Order, and include scheduled release dates. Any changes to the schedule or the quantity purchased, must be agreed upon by Anaheim Automation, Inc., and a written "Change Order" must be in processed to confirm such changes. **NOTE: Blanket Orders are Non-Cancelable and Non-Returnable.**

### **Shortages or Damages**

All claims for shortages or shipment errors must be made within 15 days after the receipt of the shipment. Anaheim Automation's liability is limited to the value of material value on the invoice. Claims for other loss or damages are filed against the carrier involved in the specific shipment.

### **Discontinued Items**

Items are subject to change or discontinuance without notice. Ask a Customer Service Representative for advice on any possible substitution for your application.

### **Returns (RMA) and Repairs**

Anything being returned to Anaheim Automation must have a RMA (Return Materials Authorization) number assigned by the factory, and it must be referenced on all the paperwork accompanying the return/repair. Items that do not reference the RMA number will not be processed. Do NOT return product using a Debit Memo. No product will be accepted for Credit after 30 days from the date of shipment. Product must be shipped with freight prepaid. ***Special, custom or modified products are Non-Returnable, and no credit shall be offered.***

Product in need of repair must have previous authorization to return it to the factory. It is critical to do so, as the advice the factory can offer is invaluable, and can often save the customer money. The factory will determine upon inspection whether the product is covered under warranty. The factory charges a "flat-rate" fee based on model number, regardless of the problem found. The fee is charged for all returns, including those where no problem is found, as inspection and test is time-consuming.

### **Cancellations and Restocking Charges**

Cancellation of any order must be approved by Anaheim Automation and will be on terms that protect us from any loss. The restocking charge is 15% on all product returned. The minimum restocking charge is \$25.00. Returns must be made within 30 days of receipt of product. Shipping expenses are paid by the customer. All products are subject to factory inspection and must be in resellable condition to receive credit. ***Special, custom and modified products are Non-Returnable and Non-Cancelable.***

### **Engineering or Technical Assistance**

Technical assistance is available at no charge to help the customer in choosing Anaheim Automation products for a specific application. However, any selection, quotation, or application suggestion offered from Anaheim Automation, its' representatives or distributors, are only to assist the customer, and in all cases, determination of fitness for purpose or use are solely the customers' responsibility. While every effort is made to offer solid advice and to produce technical data and illustrations accurately, such advice and documents are for reference only, and subject to change without notice. Programming of product is the customer's responsibility.

**All Sales are made pursuant to the Terms and Conditions herein, are in lieu of any other expressed or implied terms, including but not limited to any implied warranties.**

**ANAHEIM AUTOMATION**