

LRM17 Rod Actuators

FEATURES

- **49mm Square**
- **Push-Pull Actuator**
- **Max Load up to 170lb**
- **1.8° Step Angle**
- **Stroke Length up to 12in**
- **Multiple Lead Screw Options**



DESCRIPTION

The LRM17 Series is a Precision Rod Actuator with a maximum load capacity of 170Lbs. This rod actuator is powered by a linear step motor, boasts speeds up to 2in/s, and the stroke lengths up to 12in.

SPECIFICATIONS

Series #	Voltage (VDC)	Stroke Length (in)	Load Capacity (lb)	Screw Lead (in)	Rated Current (A)	Travel Per Step (in)	Weight (lb)
LRM17-06-102C	5.2	6	28	0.25	0.70	0.00125	1.7
LRM17-06-102P	5.2	6	170	0.03125	0.70	0.000156	1.7
LRM17-06-302C	5.6	6	28	0.25	0.85	0.00125	1.9
LRM17-06-302P	5.6	6	170	0.03125	0.85	0.000156	1.9
LRM17-12-102C	5.2	12	28	0.25	0.70	0.00125	2.3
LRM17-12-102P	5.2	12	170	0.03125	0.70	0.000156	2.3
LRM17-12-302C	5.6	12	28	0.25	0.85	0.00125	2.5
LRM17-12-302P	5.6	12	170	0.03125	0.85	0.000156	2.5

DIMENSIONS

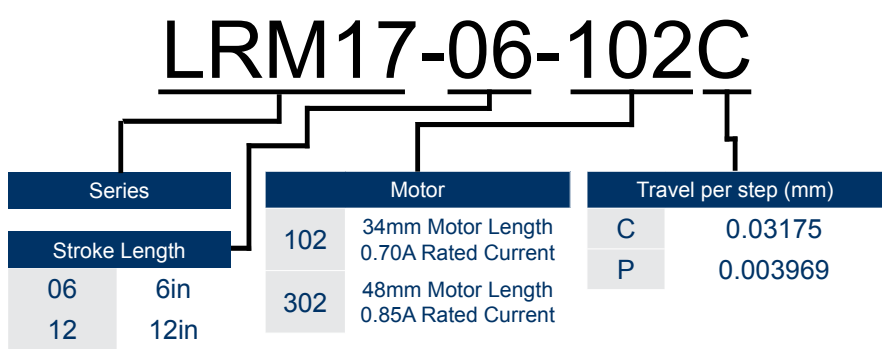

L011261

Dimensions

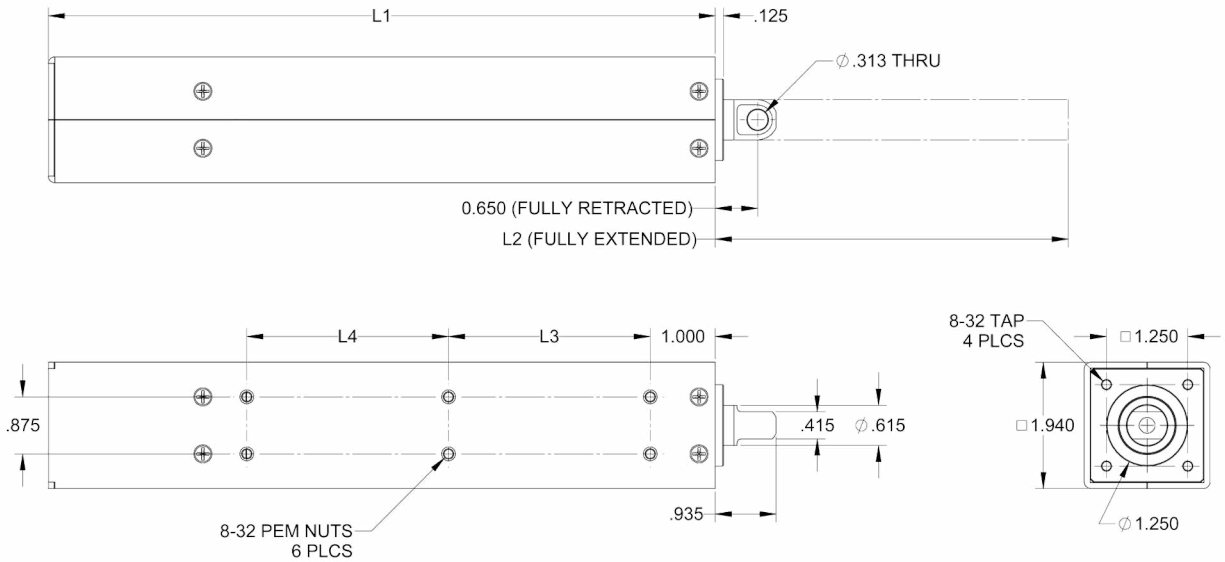

Model	L1	L2	L3	L4
LRM17-6	10.250	6.650	3.100	3.100
LRM17-12	16.250	12.650	6.100	6.100

WIRING

